



HESTORE.HU

elektronikai alkatrész áruház

EN: This Datasheet is presented by the manufacturer.

Please visit our website for pricing and availability at www.hestore.hu.

7/8" (22.2 mm) Multi Turn Wirewound Potentiometer - 533: 3 Turns/534: 10 Turns/535: 5 Turns

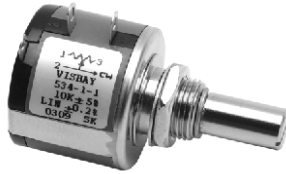
Note

- The color of this product may either be black (US market) or blue (other regions)

QUICK REFERENCE DATA	
Sensor type	ROTATIONAL, multi turn wirewound
Output type	Output by turrets
Market appliance	Industrial
Dimensions	7/8" (22.2 mm)

ELECTRICAL SPECIFICATIONS			
PARAMETER	MODEL 533	MODEL 534	MODEL 535
Resistance range - standard values	50 Ω to 20 kΩ	100 Ω to 100 kΩ	50 Ω to 50 kΩ
Capability range	5 Ω to 60 kΩ	10 Ω to 200 kΩ	5 Ω to 100 kΩ
Standard tolerance	± 5 %	± 5 %	± 5 %
Linearity (independent)	± 0.25 %	± 0.25 %	± 0.25 %
Noise	100 Ω ENR	100 Ω ENR	100 Ω ENR
Rotation (electrical and mechanical)	1080° + 10° - 0°	3600° + 10° - 0°	1800° + 10° - 0°
Power rating (at 70 °C)	1.0 W	2.0 w	1.5 W
Insulation resistance	1000 MΩ minimum 500 V _{DC}		
Dielectric strength	1000 V _{RMS} minimum 60 Hz		
Absolute minimum resistance	Not to exceed linearity x total resistance or 1 Ω, whichever is greater		
Temperature coefficient	20 ppm/°C (standard values, wire only)		
End voltage	0.25 % of total applied voltage, maximum		
Phasing	CCW end points - section 2 phased to section 1 within ± 2°		
Taps	Center tap only		

MARKING	
Unit identification	Manufacturer's name and model number, resistance value and tolerance, linearity specification date code and terminal identification. Example of a marking for a standard part: 534-11103

RESISTANCE VALUES	
533 (Ω)	50, 100, 200, 500, 1K, 2K, 5K, 10K, 20K
534 (Ω)	100, 200, 500, 1K, 2K, 5K, 10K, 20K, 50K, 100K
535 (Ω)	50, 100, 200, 500, 1K, 2K, 5K, 10K, 20K, 50K

ORDERING INFORMATION/DESCRIPTION								
The Models 533 (3 turns), 534 (10 turns) and 535 (5 turns) can be ordered by stating								
534	B	2	10K	20K	5 %	C	BO10	e4
MODEL	MOUNTING	NUMBER OF SECTION	OHMIC VALUE SECTION N° 1	OHMIC VALUE SECTION N° 2	TOLERANCE ON OHMIC VALUE	LINEARITY	PACKAGING	LEAD FINISH
	B: Bushing S: Servo					± 0.25 % (STD)	Box of 10 pieces	

SAP PART NUMBERING GUIDELINES							
534	B	2	103	203	J	C	B
MODEL	STYLE	NUMBER OF SECTION	OHMIC VALUE SECTION N° 1	OHMIC VALUE SECTION N° 2	TOLERANCE ON OHMIC VALUE	LINEARITY	PACKAGING
	B: Bushing S: Servo		103 = 10K	203 = 20K	J: ± 5 % F: ± 1 %	C: ± 0.25 % CUSTOM: L: ± 0.20 % D: ± 0.1 %	Box of 10 pieces

FEATURES

- Bushing and servo mount designs available
- Special resistance tolerances to 1 %
- Rear shaft extensions and support bearing
- Metric shaft available
- Dual gang configuration and concentric shafts
- High torque, center tap, slipping clutch on request
- Special markings and front shaft extensions
- Material categorization: For definitions of compliance please see www.vishay.com/doc?99912

RoHS
COMPLIANT

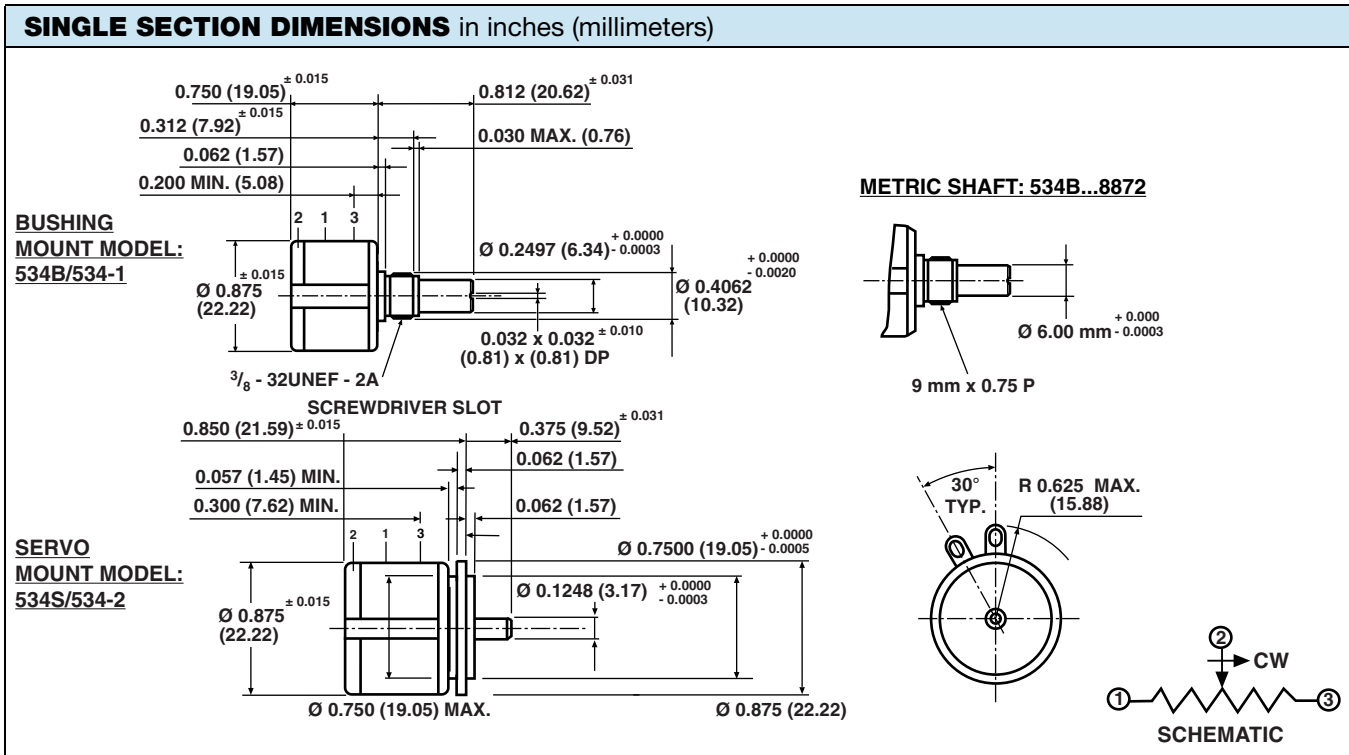

Mounting hardware, washer and panel nut, nickel plated

MECHANICAL SPECIFICATIONS		
PARAMETER		
Bearing type	Bushing: Sleeve bearing	Servo: Ball bearing
Torque (maximums): starting	534	
Section 1	0.5 oz. - in (36 g - cm)	533/535
Section 2	0.9 oz. - in (65 g - cm)	0.7 oz. - in (50 g - cm)
		1.1 oz. - in (79 g - cm)
Torque (maximums): running	534	
Section 1	0.4 oz. - in (28.80 g - cm)	533/535
Section 2	0.7 oz. - in (50.40 g - cm)	0.6 oz. - in (43.20 g - cm)
		0.9 oz. - in (64.8 g - cm)
Weight (maximums)		
Section 1	0.75 oz. (21.26 g)	
Section 2	1.25 oz. (35.44 g)	
Stop strength	75 oz. - in (static) (5.4 kg - cm)	
Ganging	2 sections maximum	

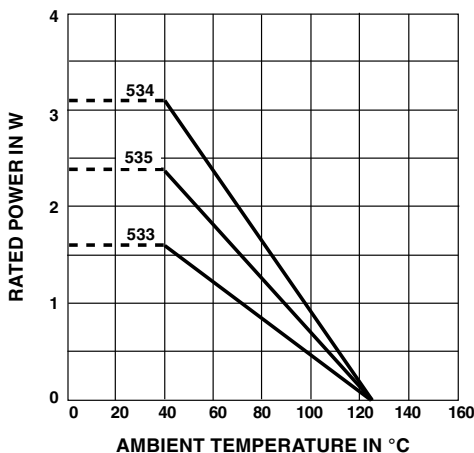
POWER RATING CHART

ENVIRONMENTAL SPECIFICATIONS	
Vibration	15 g thru 2000 Hz
Shock	50 g
Rotational life (shaft revolution)	
533	300 000
534	1 000 000
534 (servo)	> 1 000 000
535	500 000
Load life	900 h
Temperature range	- 55 °C to + 125 °C



RESISTANCE ELEMENT DATA														
RESISTANCE VALUE (Ω)			RESOLUTION (%)			OHMS PER TURN			MAXIMUM CURRENT AT 70 °C AMBIENT (mA)			MAXIMUM VOLTAGE ACROSS COIL (V)		
533	534	535	533	534	535	533	534	535	533	534	535	533	534	535
50	-	50	0.149	-	0.120	0.0746	-	0.0603	141.0	-	173.0	7.07	-	8.66
100	100	100	0.111	0.060	0.075	0.1114	0.0603	0.0746	100.0	141.0	122.0	10.0	14.1	12.2
200	200	200	0.097	0.037	0.061	0.1954	0.0746	0.1220	70.7	100.0	86.6	14.1	20.0	17.3
500	500	500	0.069	0.031	0.049	0.3424	0.1520	0.2459	44.7	63.2	54.7	22.4	31.6	27.4
1K	1K	1K	0.063	0.025	0.041	0.6331	0.2459	0.4113	31.6	44.7	38.7	31.6	44.7	38.7
2K	2K	2K	0.041	0.021	0.031	0.8206	0.4113	0.6331	22.4	31.6	27.4	44.7	63.2	54.8
5K	5K	5K	0.044	0.016	0.034	2.2330	0.8206	1.7230	14.1	20.0	17.3	70.7	100.0	86.6
10K	10K	10K	0.034	0.017	0.030	3.4510	1.7230	3.0160	10.0	14.1	12.2	100.0	141.0	122.0
20K	20K	20K	0.031	0.015	0.020	6.1790	3.0160	3.9910	7.07	10.0	8.66	141.0	200.0	173.0
-	50K	50K	-	0.009	0.015	-	4.6690	7.4560	-	6.32	5.47	-	316.0	274.0
-	100K	-	-	0.007	-	-	7.4560	-	-	4.47	-	-	447.0	-
-	-	-	-	-	-	-	-	-	-	-	-	-	-	-
-	-	-	-	-	-	-	-	-	-	-	-	-	-	-



Disclaimer

ALL PRODUCT, PRODUCT SPECIFICATIONS AND DATA ARE SUBJECT TO CHANGE WITHOUT NOTICE TO IMPROVE RELIABILITY, FUNCTION OR DESIGN OR OTHERWISE.

Vishay Intertechnology, Inc., its affiliates, agents, and employees, and all persons acting on its or their behalf (collectively, "Vishay"), disclaim any and all liability for any errors, inaccuracies or incompleteness contained in any datasheet or in any other disclosure relating to any product.

Vishay makes no warranty, representation or guarantee regarding the suitability of the products for any particular purpose or the continuing production of any product. To the maximum extent permitted by applicable law, Vishay disclaims (i) any and all liability arising out of the application or use of any product, (ii) any and all liability, including without limitation special, consequential or incidental damages, and (iii) any and all implied warranties, including warranties of fitness for particular purpose, non-infringement and merchantability.

Statements regarding the suitability of products for certain types of applications are based on Vishay's knowledge of typical requirements that are often placed on Vishay products in generic applications. Such statements are not binding statements about the suitability of products for a particular application. It is the customer's responsibility to validate that a particular product with the properties described in the product specification is suitable for use in a particular application. Parameters provided in datasheets and/or specifications may vary in different applications and performance may vary over time. All operating parameters, including typical parameters, must be validated for each customer application by the customer's technical experts. Product specifications do not expand or otherwise modify Vishay's terms and conditions of purchase, including but not limited to the warranty expressed therein.

Except as expressly indicated in writing, Vishay products are not designed for use in medical, life-saving, or life-sustaining applications or for any other application in which the failure of the Vishay product could result in personal injury or death. Customers using or selling Vishay products not expressly indicated for use in such applications do so at their own risk. Please contact authorized Vishay personnel to obtain written terms and conditions regarding products designed for such applications.

No license, express or implied, by estoppel or otherwise, to any intellectual property rights is granted by this document or by any conduct of Vishay. Product names and markings noted herein may be trademarks of their respective owners.

Material Category Policy

Vishay Intertechnology, Inc. hereby certifies that all its products that are identified as RoHS-Compliant fulfill the definitions and restrictions defined under Directive 2011/65/EU of The European Parliament and of the Council of June 8, 2011 on the restriction of the use of certain hazardous substances in electrical and electronic equipment (EEE) - recast, unless otherwise specified as non-compliant.

Please note that some Vishay documentation may still make reference to RoHS Directive 2002/95/EC. We confirm that all the products identified as being compliant to Directive 2002/95/EC conform to Directive 2011/65/EU.

Vishay Intertechnology, Inc. hereby certifies that all its products that are identified as Halogen-Free follow Halogen-Free requirements as per JEDEC JS709A standards. Please note that some Vishay documentation may still make reference to the IEC 61249-2-21 definition. We confirm that all the products identified as being compliant to IEC 61249-2-21 conform to JEDEC JS709A standards.