



HESTORE.HU

elektronikai alkatrész áruház

EN: This Datasheet is presented by the manufacturer.

Please visit our website for pricing and availability at www.hestore.hu.

SM7525

Features

- Topological structure support: Fly-back and low-cost BUCK-Boost
- Integrated 730V hybrid technology
- Universal input voltage: 85Vac~265Vac
- Constant current precision less than $\pm 5\%$
- Universal voltage compatible with 1~5W
- SunMoon patented no auxiliary winding of primary side feedback control technology without coupler, 431 and other components.
- No loop compensation
- Built-in LEB circuit
- Cycle by cycle peak current limiting
- Output open/short circuit
- Built-in soft-start
- Built-in overvoltage protection and short circuit protection
- Package: SOP8

Applications

- ◆ LED lighting driver

General Description

SM7525 is a primary side feedback controlling power chip used in off-line small power AC/DC switching power. It realizes high precision (less than $\pm 5\%$) constant current output under universal input voltage. The circuit is no loop compensation and saves opto-coupler, L431, transformer auxiliary winding and other components to reduce the cost.

The circuit integrates cycle by cycle peak current limiting, FB overvoltage protection, output open/short protection and soft-start, which optimize the reliability.

Pin Figure

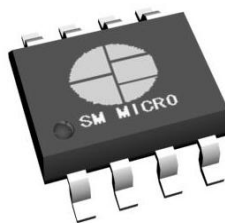

SOP8

Output Power Meter

Input Voltage	85Vac~265Vac	180Vac~265Vac
Output Power	1~5W	5~7W

Typical Application

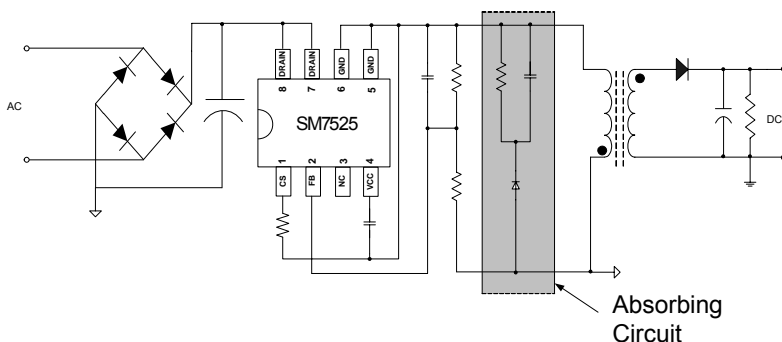

Pin Schematics

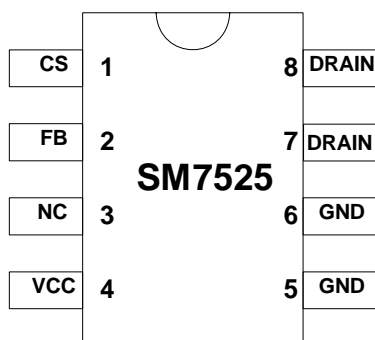

SOP8

Pin Description

Symbol	Pin Number	Pin Description
CS	1	Primary Side Peak Current Detection Port
FB	2	Output Voltage Feedback Port
NC	3	No Connection
VDD	4	Internal Power Supply Voltage Port
GND	5,6	Ground
DRAIN	7,8	Open-drain of MOSFET

Limiting Values

Limiting Parameters (TA= 25°C)

Symbol	Description	Range	Unit
VDD	Operating Voltage	-0.3~6	V
V _{FB}	FB Input Voltage	~	V
V _{CS}	CS Input Voltage	-0.3~7.0	V
T _A	Operating Temperature	-20~125	°C
T _{stg}	Storage Temperature	-40~150	°C
V _{ESD}	HBM	4	KV
R _{θja}	Thermal Resistance	65	°C/W
V _{ds}	Drain Source Breakdown Voltage	-0.3~730	V

Electrical Operating Parameters

((No special instruction, normal condition T_A=25°C, VDD=6V)

Symbol	Description	Range			Unit
		Min	Type	Max	
ICC	Static Current		-250		uA
V _{cc}	Power Supply Voltage		6		V
V _{cs}	Current Detection Threshold		620		mV
T _{LEB}	Leading Edge Blanking Time		450		ns
V _{FBMIN}	FB Minimum Threshold Value		300		mV
V _{FBMAX}	FB Overvoltage Threshold		4		V
T _{DEM_MIN}	Minimum Degaussing Time		5		us
D _{MAX}	Maximum Duty Cycle		42		%
R _{DSON}	On-Resistance		15		Ohm
B _{V_DSS}	Drain Source Breakdown Voltage		730		V
V _{cc_uvlo}	V _{cc} under-voltage protection threshold		4		V

Functional Description

- ◆ SM7525 is a primary side feedback controlling power chip used in off-line small power AC/DC switching power. It realizes high precision (less than $\pm 5\%$) constant current output under universal input voltage. SM7525 controls system output through primary side sampling mode. It integrates high voltage process and saves opto-coupler, TL431 and other components. Circuit contains cycle-by-cycle peak current limiting, FB overvoltage protection, output open/short circuit protection and soft-start function to optimize the system reliability.

- ◆ Start-up and Control

SM7525 contains high-voltage power switch. Traditional circuit external startup resistor and power supply circuit of auxiliary winding can be eliminated by high-voltage startup, which reduces system cost greatly.

Operating Principle

SM7525 must operate under DCM to realize high precision of the primary side constant current control, and fly-back power application. The circuit controls current and voltage through reflected voltage from detecting primary side auxiliary winding. Output current is only controlled by transformer turns ratio and primary current peak value:

$$I_o = 2/7 \times N \times I_p \quad (1)$$

Note: I_o is output current ; N is transformer turns ratio; η is conversion efficiency

- ◆ Operating Frequency

SM7525 switching frequency is controlled by the load without external setting components (Maximum switching frequency less than 65K). In discontinuous mode fly-back power supply, the maximum output power is:

$$P_o = \frac{1}{2} \times L_p \times F_{sw} \times I_p^2 \quad (3)$$

L_p is primary side auxiliary winding inductance; I_p is primary side auxiliary winding peak current. Formula 3 shows the change in primary side auxiliary winding inductance leads to maximum power output and constant current change under constant current mode. In order to compensate for the changes in the primary side inductance, internal loop locks the switch frequency. The frequency is shown below:

$$F_{sw} = \frac{4}{7 \times T_{DEMAG}} \quad (4)$$

Because degaussing time T_{DEMAG} is inversely proportional to inductance and the product of L_p and F_{sw} is unchanged through frequency lock, maximum output power and constant current under constant current mode will not change with the primary side inductance. SM7525 can compensate inductance maximum $\pm 10\%$.

◆ Current Detection and LEB

SM7525 controls the power switch by detecting the resistor voltage of CS, so that the transformer primary current control is achieved and cycle-by cycle peak current limiting is provided. Switch current inputs CS pin by accessing to the external detection resistor.

In order to eliminate the interference caused by open of high voltage power MOSFET, it is built-in leading edge blanking circuit. Therefore, there is no need for external RC filter circuit and reducing cost is achieved.

◆ Protection Control

SM7525 improves the various protection functions and optimizes the power reliability including cycle-by-cycle peak current limiting, short circuit protection, FB overvoltage protection and soft-start.

PCB Layout Precautions

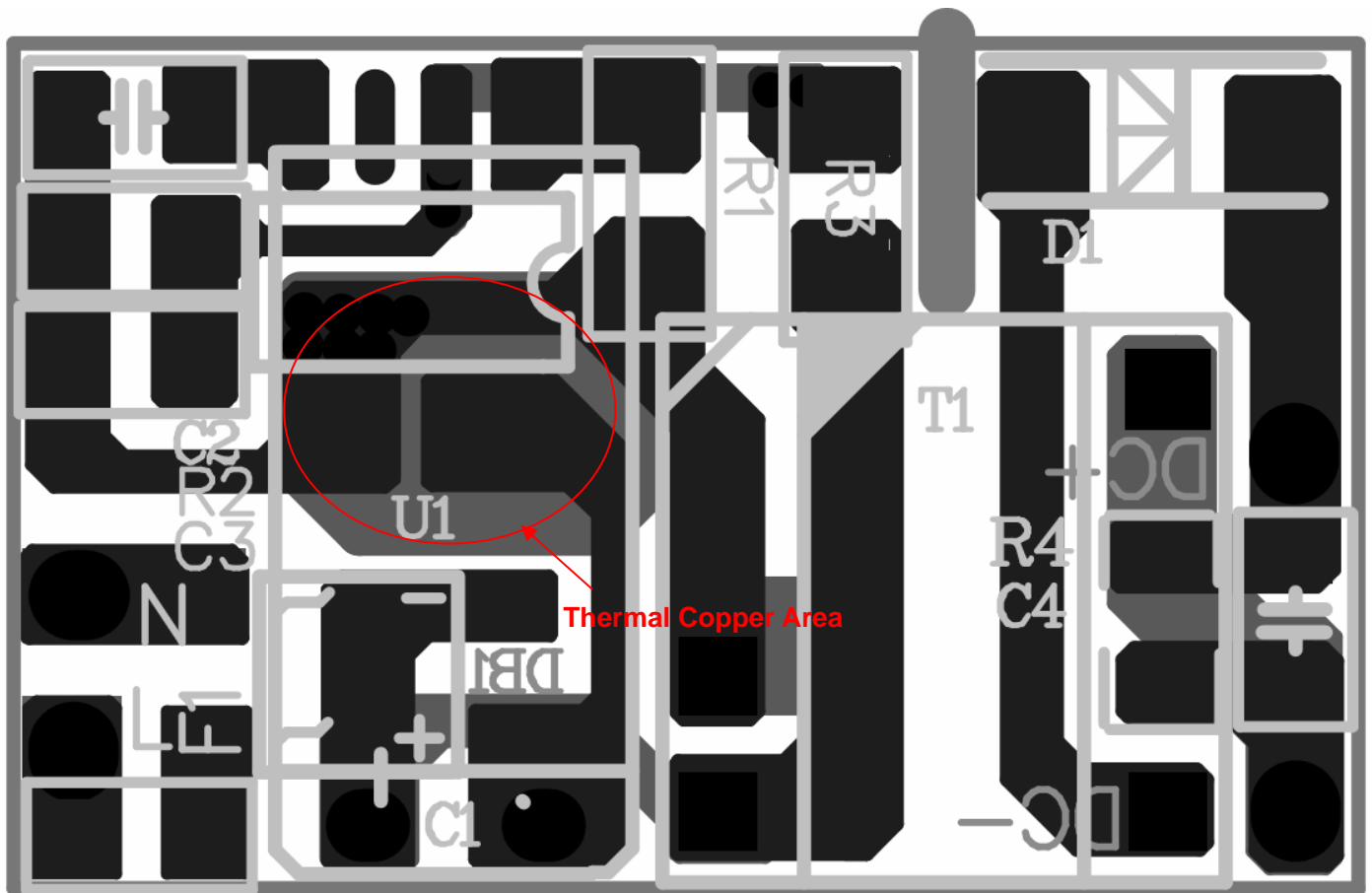

- ◆ Pin 5 and 6 of IC need copper to dissipate, which means shopping copper in the bottom layer and the surface layer is necessary to reduce temperature and improve performance.
- ◆ The distance between DRAIN pin wiring and transformer should be as short as possible. It is appropriate to keep small loop area and no big area copper.
- ◆ FB pin wiring should be away from high-voltage loop with more than 1mm spacing to avoid interference.

Typical Application Circuit

◆ SM7525 18V/300mA LED high-end lighting application circuit

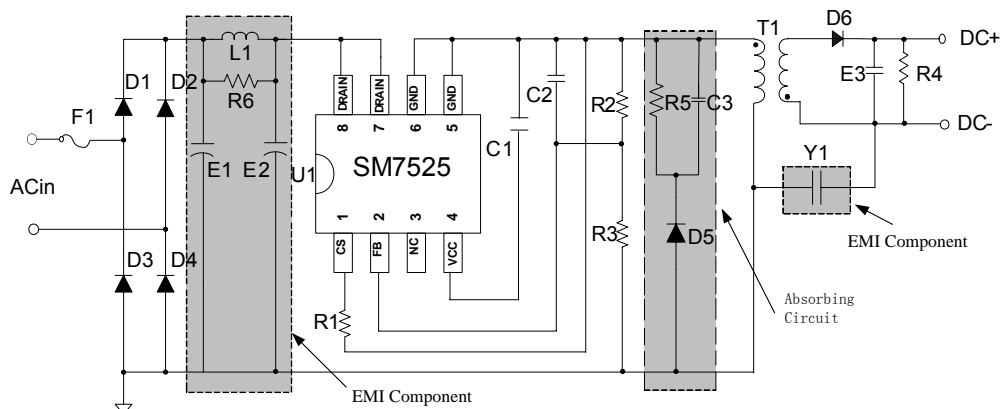

Schematic:

BOM Diagram:

Symbol	Parameters	Bit Number	Parameters
D1、 D2、 D3、 D4、 D5	RS1M	C1	1uF/16V
D6	ES1J	C2	15pF/16V
R1	1.5Ω/1206	C3	102/1KV
R2	39K	U1	SM7525
R3	1M/1206	F1	0.5A/250V
R4、 R6	20K/1206	T1	EE13
R5	120K/1206	L1	2.2mH/1W
E1、 E2	4.7uf/400V	Y1	102/250V
E3	10uF/35V		

Transform parameters;

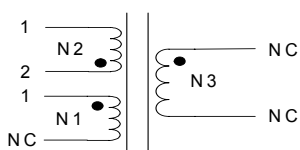

• Dotted terminal

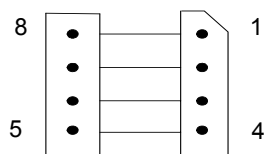

Bottom View

Note:

1. EE13(4+4), Horizontal PC40
2. Primary Inductance $L_p=2.0\text{mH}$, Leakage Inductance: $<5\%$ of L_p
3. Leakage Current(Primary to Second) $<2\text{mA}/60\text{s}@3000\text{VAC}$
4. Leakage Current (Primary to Magnetic core) $<2\text{mA}/60\text{s}@3000\text{VAC}$
5. Leakage Current (Second to Magnetic core) $<2\text{mA}/60\text{s}@3000\text{VAC}$

N3(NC)	NC)	$\Phi 0.25*1*36\text{T}$
N2(2)	1)	$\Phi 0.17*1*140\text{T}$
N1(1)	NC)	$\Phi 0.17*1$ Overall core

◆ SM7525 60V/100mA BUCK-Boost Power Solution

Schematic:

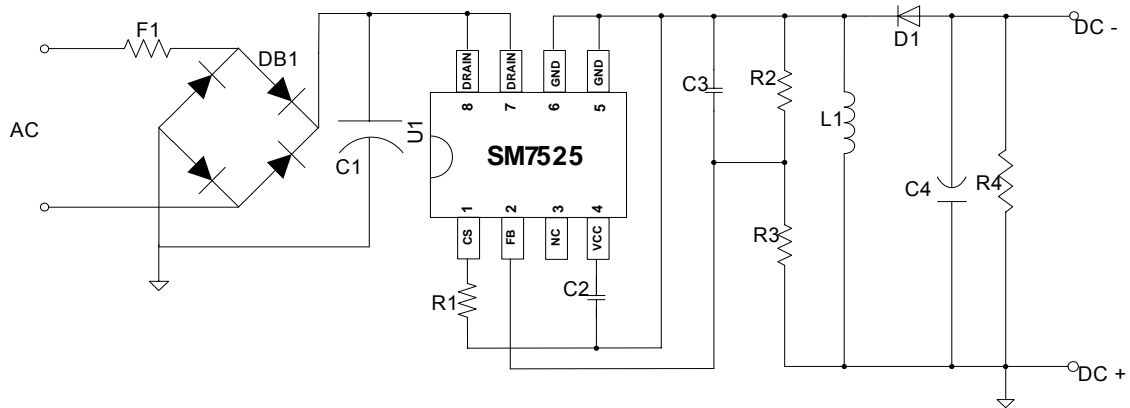

BOM Diagram:

Symbol	Parameters	Bit Number	Parameters
DB1	MB6S	C2	1uF
D1	ES1J	C3	15pF
R1	1.6Ω/1206	C4	10uF/1206
R2	75K	F1	10R Winding Resistance
R3	2M/1206	L1	2.4mh/Saturation Current>400mA
R4	120K	U1	SM7525
C1	6.8uf/400V		

◆ SM7525 Conduction Pictures

Line L:

EMI TEST REPORT

Organization:	Operator:	EUT:
Place:	Time: 2012/12/5/17:35	Test equipment: KH3935
Detector: PK+AV	Test-time(ms): 20	SN: 1135217
Limit: EN55022B	Transductor(PK/AV): PK-1 / AV-1	
Remark:		

Start(MHz)	End(MHz)	Step(MHz)
0.150	2.000	0.002
2.000	10.000	0.010
10.000	30.000	0.025

dBuV

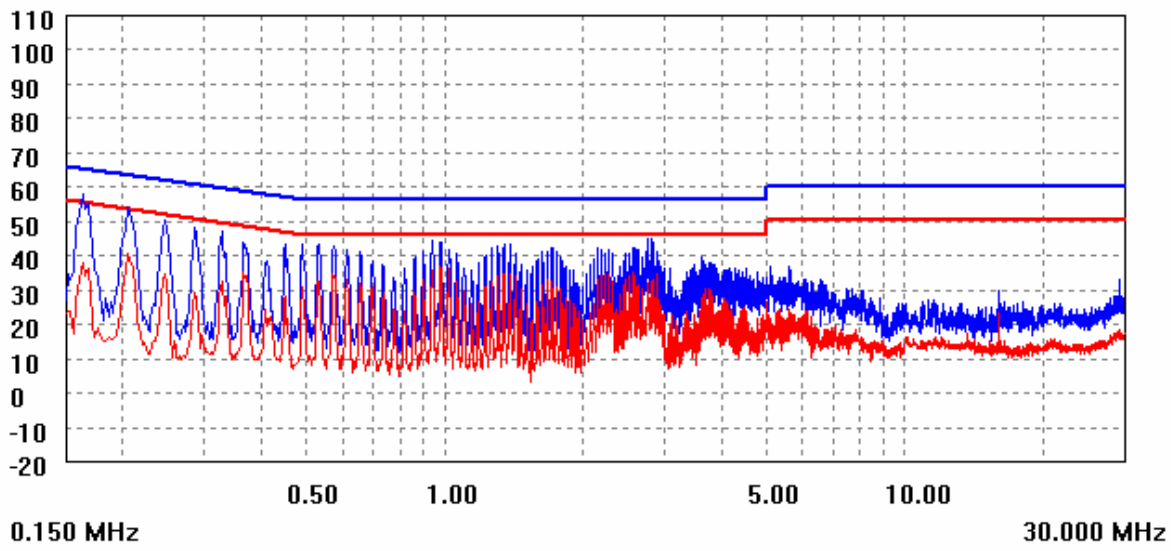

Line N:

EMI TEST REPORT

Organization:	Operator:	EUT:
Place:	Time: 2012/12/5/17:41	Test equipment: KH3935
Detector: PK+AV	Test-time[ms]: 20	SN: 1135217
Limit: EN55022B	Transductor(PK/AV): PK-1 / AV-1	
Remark:		

Start(MHz)	End(MHz)	Step(MHz)
0.150	2.000	0.002
2.000	10.000	0.010
10.000	30.000	0.025

dBuV

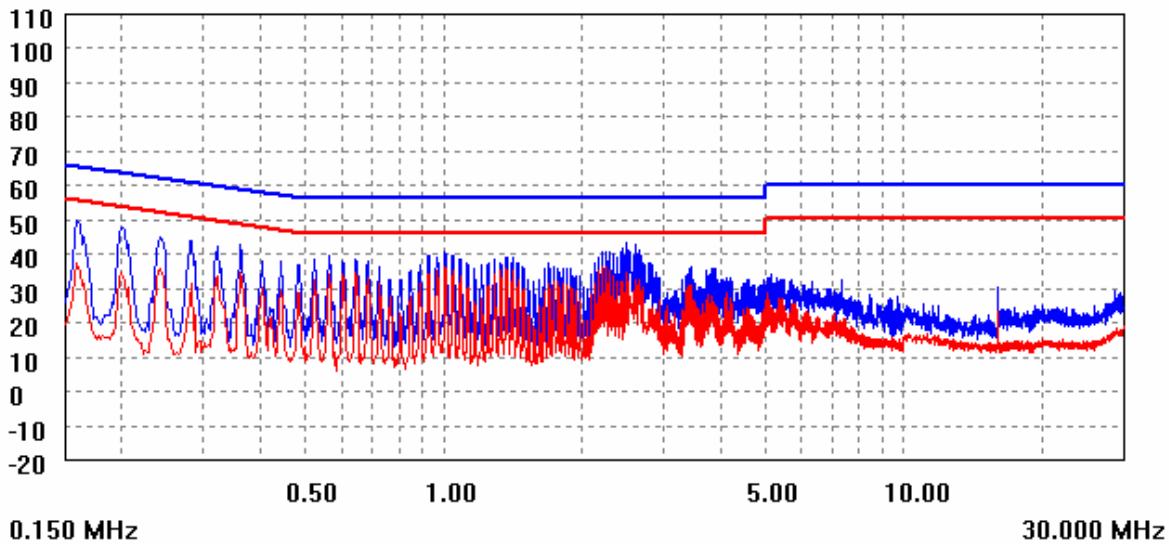

Package:

SOP8

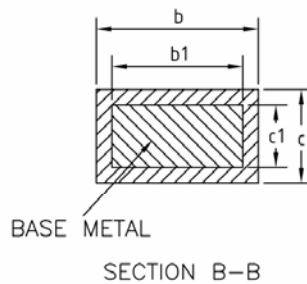
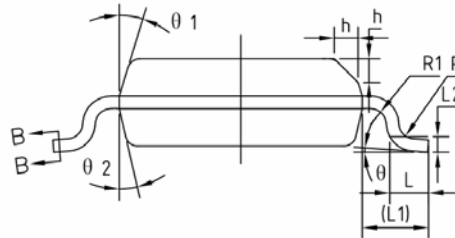
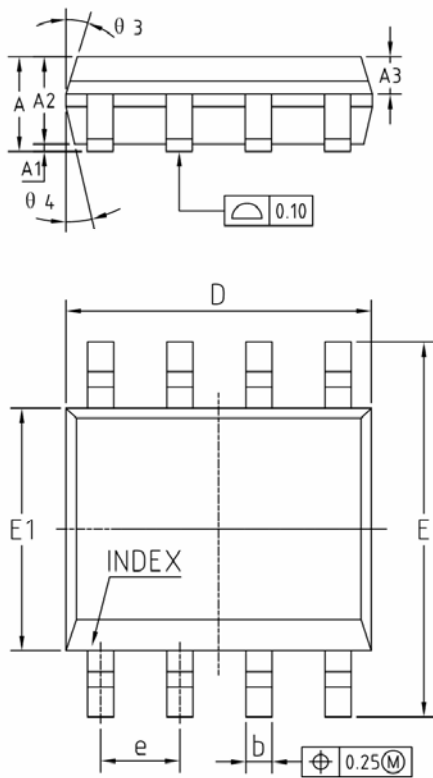

COMMON DIMENSIONS
(UNITS OF MEASURE=MILLIMETER)

SYMBOL	MIN	NOM	MAX
A	1.35	1.55	1.75
A1	0.10	0.15	0.25
A2	1.25	1.40	1.65
A3	0.50	0.60	0.70
b	0.38	—	0.51
b1	0.37	0.42	0.47
c	0.17	—	0.25
c1	0.17	0.20	0.23
D	4.80	4.90	5.00
E	5.80	6.00	6.20
E1	3.80	3.90	4.00
e	1.27BSC		
L	0.45	0.60	0.80
L1	1.04REF		
L2	0.25BSC		
R	0.07	—	—
R1	0.07	—	—
h	0.30	0.40	0.50
θ	0°	—	8°
$\theta 1$	15°	17°	19°
$\theta 2$	11°	13°	15°
$\theta 3$	15°	17°	19°
$\theta 4$	11°	13°	15°

NOTES:

ALL DIMENSIONS MEET JEDEC STANDARD MS-012 AA
DO NOT INCLUDE MOLD FLASH OR PROTRUSIONS.