



HESTORE.HU

elektronikai alkatrész áruház

EN: This Datasheet is presented by the manufacturer.

Please visit our website for pricing and availability at www.hestore.hu.

Features

- ◆ SIP-package fits existing TO-220 footprint
- ◆ Suitable for positive & negative output circuit
- ◆ Pin compatible with LMxx linear regulators
- ◆ Built in filter capacitors
- ◆ Operation temp. range -40°C to $+85^{\circ}\text{C}$
- ◆ No heat-sink required
- ◆ Over-temperature protection
- ◆ Short circuit protection
- ◆ Wide input range up to 42 VDC
- ◆ Excellent line / load regulation
- ◆ Low standby current
- ◆ 3-year product warranty

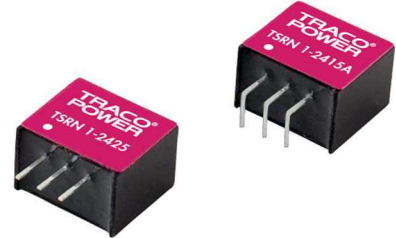

The new TSRN-1 series step-down switching regulators are drop-in replacement for inefficient 78xx linear regulators. A high efficiency up to 95 % allows full load operation up to $+70^{\circ}\text{C}$ ($+85^{\circ}\text{C}$ with derating) ambient temperature without the need of any heat-sink or forced air cooling.

The TSRN-1 switching regulators provide other significant features over linear regulators, i.e. better output accuracy ($\pm 2\%$), lower standby current of $\sim 2\text{ mA}$ and no requirement of external capacitors. They are suitable for positive or negative output circuits. The high efficiency and low standby power consumption make these regulators an ideal solution for energy sensitive applications.

Models

Order code ¹⁾		Input voltage range ²⁾ / (nominal)	Output voltage	Output current max.	Efficiency typ.	
straight pins	angular pins				@ Vin min.	@ Vin max.
Positive output circuit						
TSRN 1-2415	TSRN 1-2415A	4.6 – 42 VDC (12 VDC)	1.5 VDC	1.0 A	77 %	66 %
TSRN 1-2418	TSRN 1-2418A	4.6 – 42 VDC (12 VDC)	1.8 VDC		80 %	70 %
TSRN 1-2425	TSRN 1-2425A	4.6 – 42 VDC (12 VDC)	2.5 VDC		83 %	75 %
TSRN 1-2433	TSRN 1-2433A	4.6 – 42 VDC (12 VDC)	3.3 VDC		87 %	79 %
TSRN 1-2450	TSRN 1-2450A	6.5 – 42 VDC (12 VDC)	5.0 VDC		91 %	83 %
TSRN 1-2465	TSRN 1-2465A	8.0 – 42 VDC (12 VDC)	6.5 VDC		93 %	86 %
TSRN 1-2490	TSRN 1-2490A	10.5 – 42 VDC (12 VDC)	9.0 VDC		94 %	88 %
TSRN 1-24120	TSRN 1-24120A	13.5 – 42 VDC (24 VDC)	12 VDC		95 %	91 %
TSRN 1-24150	TSRN 1-24150A	16.5 – 42 VDC (24 VDC)	15 VDC		95 %	92 %
Negative output circuit						
TSRN 1-2415	TSRN 1-2415A	4.6 – 32 VDC (12 VDC)	-1.5 VDC	0.6 A	69 %	64 %
TSRN 1-2418	TSRN 1-2418A	4.6 – 32 VDC (12 VDC)	-1.8 VDC	0.6 A	72 %	67 %
TSRN 1-2425	TSRN 1-2425A	4.6 – 32 VDC (12 VDC)	-2.5 VDC	0.6 A	72 %	74 %
TSRN 1-2433	TSRN 1-2433A	4.6 – 32 VDC (12 VDC)	-3.3 VDC	0.6 A	74 %	77 %
TSRN 1-2450	TSRN 1-2450A	6.5 – 31 VDC (12 VDC)	-5.0 VDC	0.4 A	79 %	78 %
TSRN 1-2465	TSRN 1-2465A	8.0 – 29 VDC (12 VDC)	-6.5 VDC	0.3 A	84 %	80 %
TSRN 1-2490	TSRN 1-2490A	10.5 – 27 VDC (12 VDC)	-9.0 VDC	0.3 A	85 %	82 %
TSRN 1-24120	TSRN 1-24120A	13.5 – 24 VDC (12 VDC)	-12 VDC	0.3 A	85 %	85 %
TSRN 1-24150	TSRN 1-24150A	16.5 – 21 VDC (12 VDC)	-15 VDC	0.2 A	85 %	84 %

1) Same order code for positive and negative output operation, see page 3 for circuits.

2) For input voltage higher 36 VDC an input capacitor 22 μF / 50 V is required

Input Specifications

No load input current	<= 3.3 VDC output models: 1 mA typ. >= 5.0 VDC Output models: 3 mA typ
Reflected ripple current	100 mA typ.
Input filter	internal capacitors

Output Specifications

Voltage set accuracy	±2 % (at full load)
Regulation	– Input variation 0.2 % – Load variation (10 – 100 %) 1.5 VDC models: 0.6 % straight pin vers., 1.2 % angular pin vers. 1.8 VDC models: 0.4 % straight pin vers., 1.2 % angular pin vers. other models: 0.4 % (all versions)
Startup voltage overshoot	1.0 % max.
Minimum load	not required
Ripple and noise (20 MHz Bandwidth)	1.5 – 6.5 VDC models: 50 mVpk-pk max. 9 – 15 VDC models: 75 mVpk-pk max.
Temperature coefficient	±0.015 % / °C max.
Dynamic load response (change of 50% to 100% load)	150 mV max. peak variation 250 µS max. response time
Startup time	– start up time at nominal Vin, constant resistive load 5 mS typ. – rise time for 10 % to 90 % Vout 3.5 mS typ.
Short circuit protection	continuous, automatic recovery
Current limitation (for positive output circuit)	at 2.0 A typ.
Capacitive load	470 µF max.

General Specifications

Temperature ranges	– Operating –40°C to +85°C – Max. casing temperature tba. – Storage –55°C to +125°C
Derating	2.7 %/K above +70°C
Thermal shock	acc. MIL-STD-810F
Vibration	acc. MIL-STD-810F
Overtemperature protection	at +170°C (on internal IC)
Humidity (non condensing)	90 % rel H max.
Reliability, calculated MTBF (MIL-HDBK-217F, at +25°C, ground benign)	>6'000'000 h
Isolation voltage	none
Switching frequency	1.5 – 3.3 VDC models: 300 kHz typ. 5.0 – 15 VDC models: 580 kHz typ.

Physical Specifications

Casing material	non-conductive plastic
Potting material	silicon (flammability to UL 94V-0 rated)
Weight	1.9 g (0.07 oz)
Soldering profile	max. +265°C / 10 sec. (wave soldering)

All specifications valid at nominal input voltage, full load and +25°C after warm-up time unless otherwise stated.

Applications notes

Positive output operation:

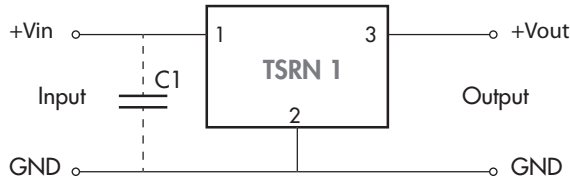

C1 = 22 μ F / 50 V (required only if input voltage is higher than 36 V)

Negative output operation:

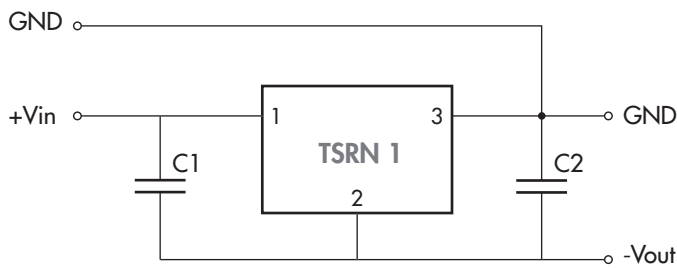

C1 = 10 μ F / 50 V, 1210 X5R MLCC
C2 = 10 μ F / 25 V, 1206 X5R MLCC

Outline Dimensions

Straight pin version

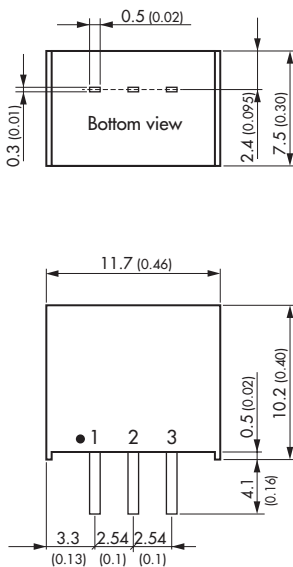

Angular pin version (suffix A)

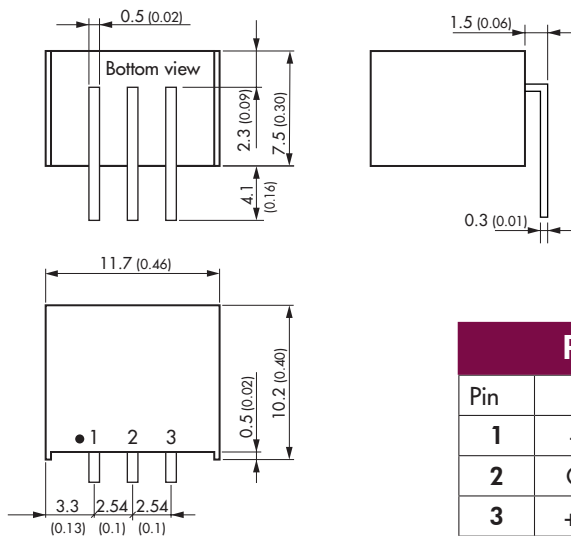

Pin-Out		
Pin	pos.	neg.
1	+Vin	+Vin
2	GND	-Vout
3	+Vout	GND

Dimensions in [mm], () = Inch
Pin pitch tolerances: ± 0.25 (± 0.01)
Pin profile tolerance: ± 0.1 (± 0.004)
Other tolerances: ± 0.5 (± 0.02)

Specifications can be changed any time without notice.