



HESTORE.HU

elektronikai alkatrész áruház

EN: This Datasheet is presented by the manufacturer.

Please visit our website for pricing and availability at www.hestore.hu.

1. Buzzers

1.1. Standard series

Since 1977, Sonitron has been investing in research and development, optimising his standard series, which are used today under the most extreme and difficult environmental circumstances, by clients such as the Nato, Airbus, Volvo Penta, Dräger, Knogo, Stanley Door Systems,...

During the last 25 years the standard series have proved to be the prime alarm giving your equipment an added value. Several thousands of clients all over the world have chosen the reliability and the excellent quality of piezo ceramic buzzers of Sonitron.

The range has recently expanded with 4 new models producing over 100 dB(A) at 1 meter as a single tone, intermittent, sweep and warbler.

The housing of the standard series is now available with a square mountable flange.



Square flange model

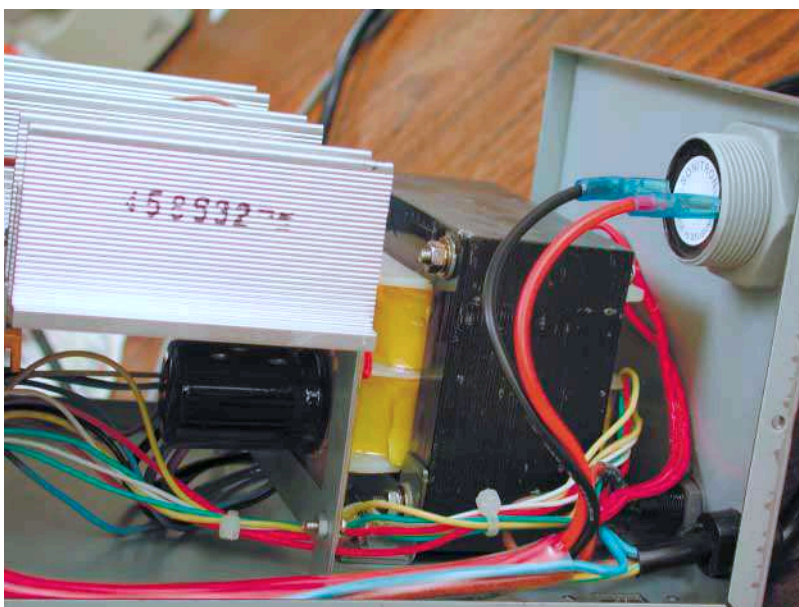

Nut mounted with two wire connections

1.1.1. INTRODUCTION



The standard series are based on the highest piezo technology and are considered to be the most robust series for industrial applications. The standard buzzers use a bent edge membrane, which is fixed and glued into the housing, guaranteeing shock, dust and waterproof operations. The different standard models cover a very wide range of applications, offering functions such as continuous, intermittent, sweep and warbler, with a sound output over 100 dB(A).

All standard products are manufactured to meet various mounting methods, such as PCB or panel mounting and are therefore equipped with either pins or fast-on terminals. The standard series include military models, extra loud types, as well as models operating at very low voltage (SC 0715 BL at 0.7V) and very low current consumption (SP27 = 4,8 mA at 9V).

1.1.2. ADVANTAGES

- extremely high sound pressure level with a very clear and penetrating sound output
- solid state shock proof buzzer. Dust and waterproof, rated to IP67
- PCB and panel mounting; pin or fast-on terminals
- very high reliability
- low power consumption
- wide operating supply range
- wide temperature range

1.1.3. APPLICATIONS

- alarms
- industrial enunciator equipment
- monitoring and test equipment
- medical equipment
- military equipment
- trucks and automobiles, boats and airplanes
- signalling & process control equipment
- fire detectors etc.
- etc.

1.1.4. SPECIFICATIONS

Model	Function	Operating voltage		Frequency (±15%) Hz	Pulse rate Hz	Operating current mA		Sound pressure dB(A) *
		min Vdc	Max Vdc			at V min.	At V max.	
SC 235 A	contin.	2	35	2500	-	0.3	8.6	73
SC 235 B	contin.	2	35	3500	-	0.4	8.4	87
SC 515 C	contin.	5	15	3000	-	25	130	102
SCI 535 A1	multif.	5	35	2500	1	1.4	12.5	77
SCI 535 B1	multif.	5	35	3500	1	1.4	12.2	86
SCI 515 C	multif.	5	15	3000	1	13	70	96
SCI 535 A5	multif.	5	35	2500	5	1.4	12.5	77
SCI 535 B5	multif.	5	35	3500	5	1.4	12.2	86
SCR 535 A	multif.	5	35	2500	20	1.4	12.6	82
SCR 535 B	multif.	5	35	3500	20	1.4	12.6	84
SW 535 B	warbler	5	35	3500	-	1.3	10.6	87
SW 515 C	warbler	5	15	3000	-	30	120	104
SUC 516 A	contin.	5	16	2500	-	1.8	13.3	92
SUC 516 B	contin.	5	16	3500	-	0.8	13.0	90
SULC 516 B	contin.	5	16	3500	-	2.0	13.3	97
SULI 516 B1	intermit.	5	16	3500	1	1.2	11.6	94
SULI 516 B5	intermit.	5	16	3500	5	1.2	11.6	94
SUM 516 A1	multif.	5	16	2500	1	1.8	11.6	93
SUM 516 A5	multif.	5	16	2500	5	1.8	11.6	93
SULM 516 B1	multif.	5	16	3500	1	2.4	14.2	96
SULM 516 B5	multif.	5	16	3500	5	2.4	14.2	96
SC 0715 BL	contin.	0.7	15	3500	-	0.3	13.4	98
SWP 515 C	sweep	5	15	3000	-	55	110	102
SP27	contin.	3.5	9	3500	-	1.6	4.8	94 (9V)

*All measurements are made at 1 meter at 12V in free air at 21°C
The weight of the standard buzzers varies from 13 g to 24 g

1.1.5. MULTI-FUNCTIONALITY OF THE STANDARD BUZZERS

The standard series offer the client several functions in one single buzzer. The selection of a function is illustrated in the scheme below.

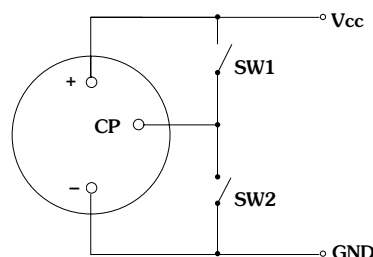

SW1	SW 2	SCI 535	SCI 515	SCR	SU(L)M
open	open	intermittent	intermittent	cricket	intermittent
closed	open	stop	continuous	stop	stop
open	closed	continuous	stop	continuous	continuous

Operating temperature	-35°C to +75°C
Storage temperature	-40°C to +85°C
Life time (at 21°C)	See expected life time curve in addendum
Case material	ABS (UL rating: 94 HB)
Standard colour of case	Grey (except the SP27 which is black)
Terminal material	Tinned brass for both pin terminals and fast-on terminals
Supply voltage	The standard buzzers are not damaged by reverse voltage connection (except the SP27 types).
Mounting	PC-board: by soldering the terminals. Front panel mounting: the buzzers can be mounted in panels up to 14 mm thickness (SP27 max. 7 mm). They are locked with a locking pin (diameter 1mm) and secured to the panel with a plastic nut. Foresee a hole of diameter 32 mm (1.14"). Maximum torque on plastic nut: 6 Nm The step of the thread is 1.5 mm

1.1.6. SELECTION GUIDE

The selection of an acoustic signal can be complex. That is the reason why we present below our standard models with their most appropriate application.

- SC 235 A
SCI 235 A1/A5

General purpose buzzer with medium sound output for soft alarm in industrial and military applications where a high reliability is requested. These buzzers can be used in a wide supply voltage range.
- SC 235 B
SCI 235 B1/B5

General purpose buzzer with high sound output for low power consumption. Ideally suitable for alarm and industrial sound signals. These models combine high performances and great reliability. The SC 235 B is considered today as the most popular type.
- SW 535 B
SCR 535 B

A warbling or cricket tone with a special sound effect for warning and alerting signalling devices. These buzzers are also used as a warning device with discrimination against the existing background noise.
- SP27

Small size buzzer to be used in applications where space is limited. (Max. supply voltage is 9 Vdc). See also information in addendum.
- SUM 516 A1/A5

A universal buzzer type with a selection of three functions: continuous, intermittent or stop. High sound output for low power consumption and low supply voltages. This type can be used for multiple applications where a soft signal is required and a high reliability is a must.
- SULM 516 B5

A universal buzzer with a selection mode of different functions: continuous, intermittent or stop. High sound output at very low power consumption. It can be used in all alarm and warning signals where performance, power consumption and size are important. The SULI and the SUC models are simplified versions of the SULM 516 B5 that can be used when mode control is not required.
- SC 0715 BL

Special loud buzzer that already functions at very low voltage (0.7 Vdc), going up to 12 Vdc, producing 98 dB(A) at 1m. Wide range of applications, including battery powered alarms.
- SC 515 C
SCI 515 C

Extreme loud buzzers for multiple applications requiring a highly penetrating sound. The SCI 515 C interrupts the sound, creating more attention.
- SW 515 C
SWP 515 C

Extreme loud buzzer with warbler or sweep tones. These buzzers produce a very aggressive sound. They are perfect alarm bells and warning devices for all kinds of applications.

1.1.7. ELECTRICAL PARAMETERS

ELECTRICAL PARAMETERS: current consumption vs. voltage

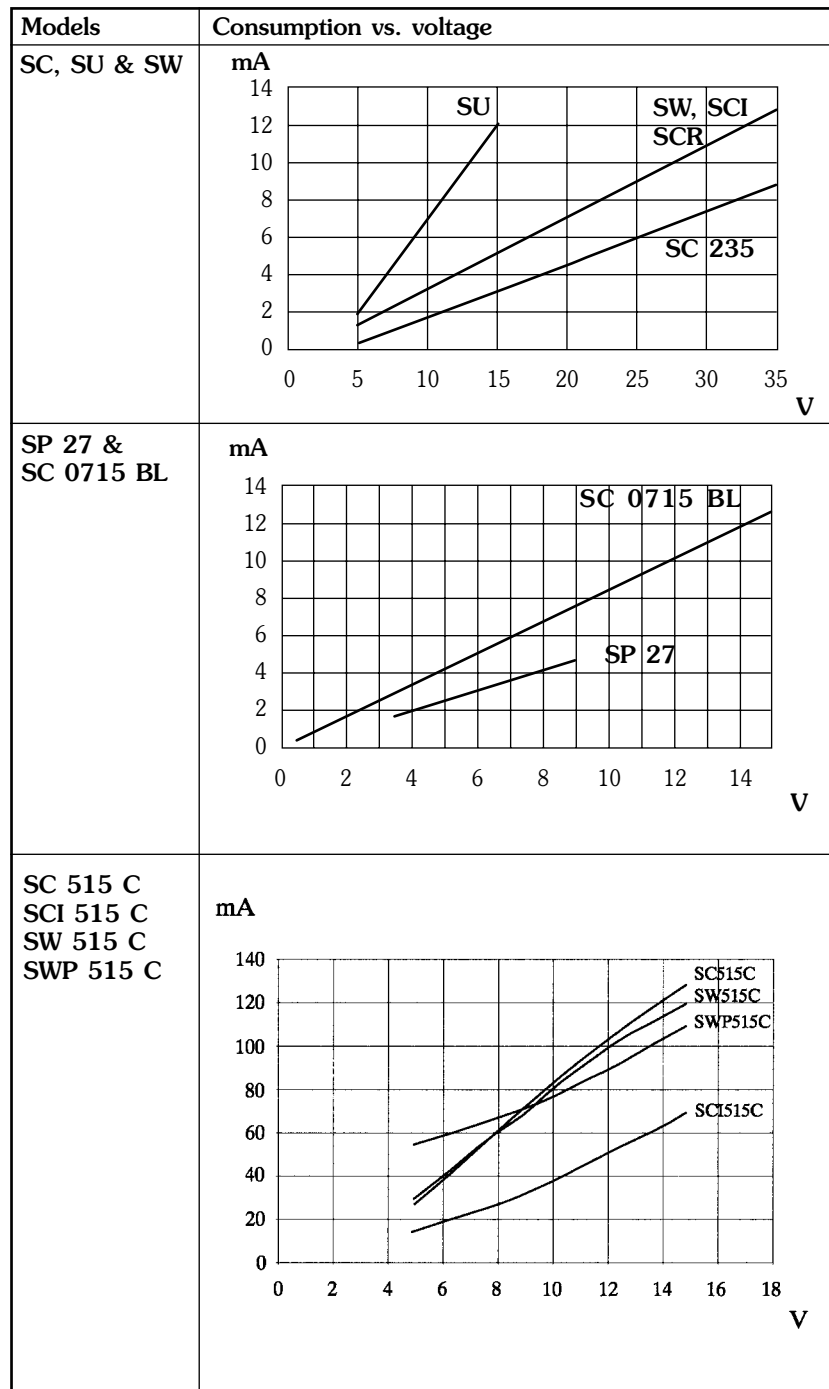

All measurements are made at 1 meter in free air at 21°C.

ELECTRICAL PARAMETERS: sound pressure level vs. voltage

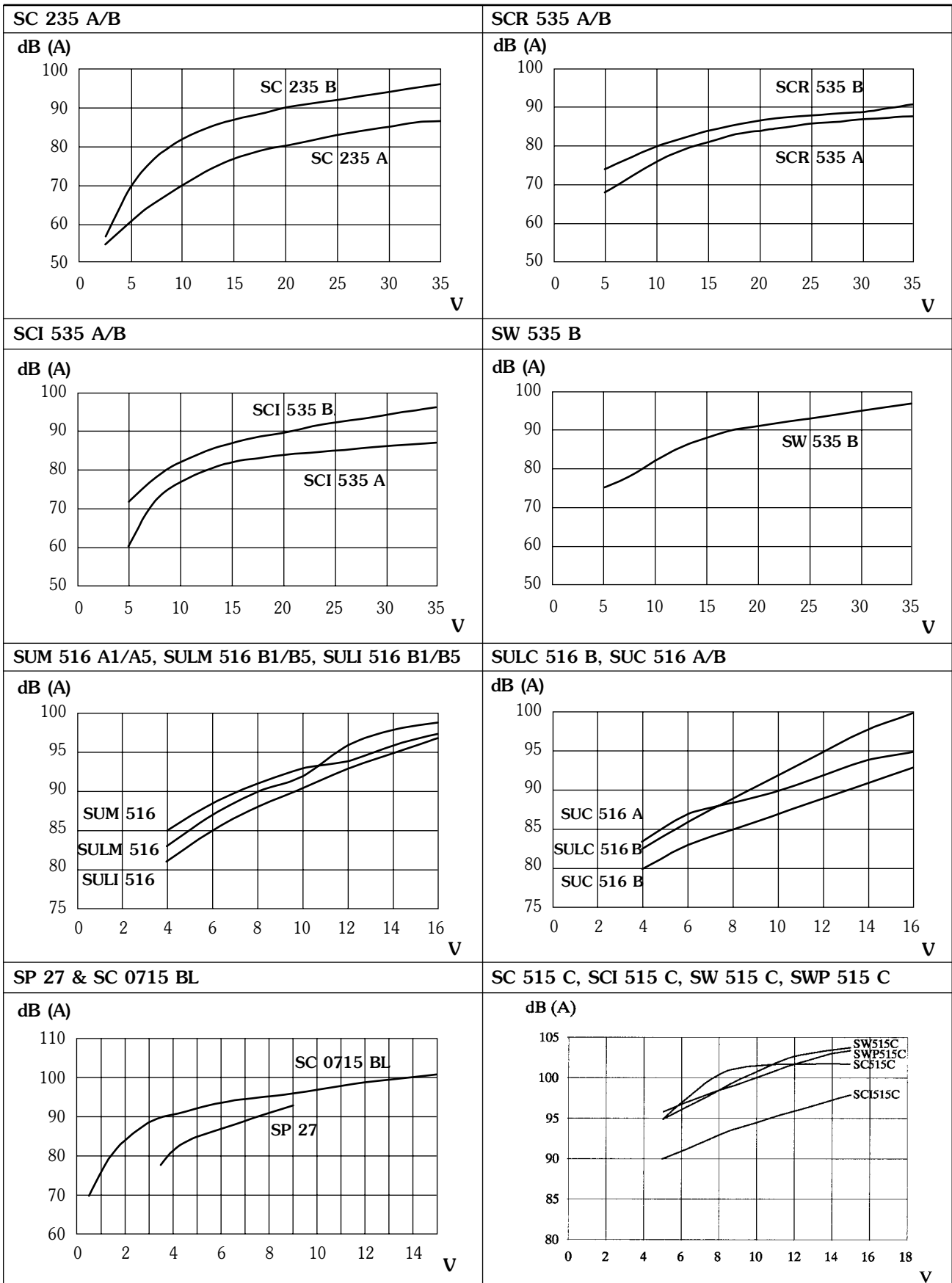

All measurements are made at 1 meter in free air at 21°C.

1.1.8. DIMENSIONS

Standard model

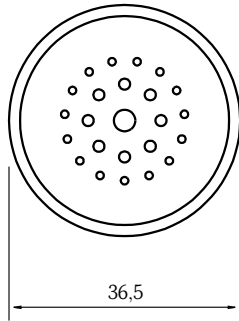

Square front model

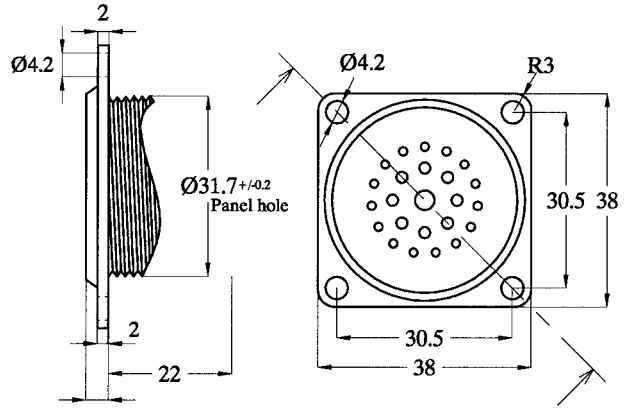

Models SC, SCI, SW & SWP

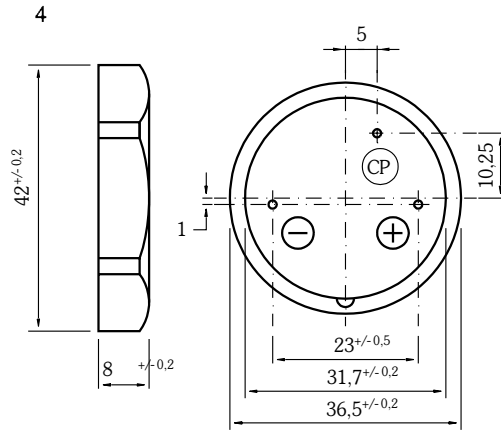
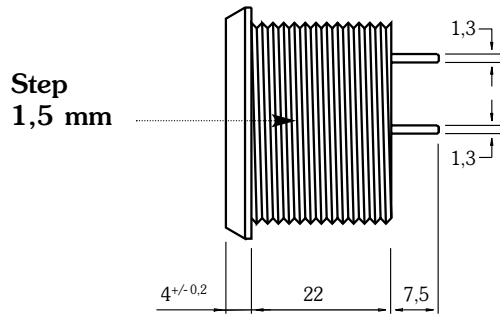

Models SU

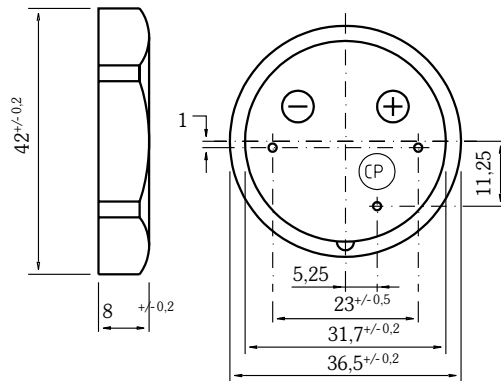
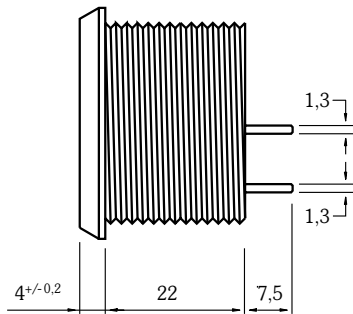

Model SP27

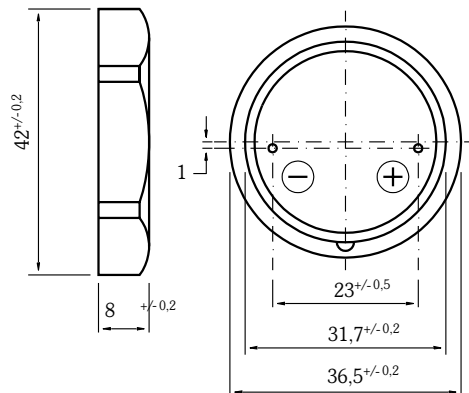
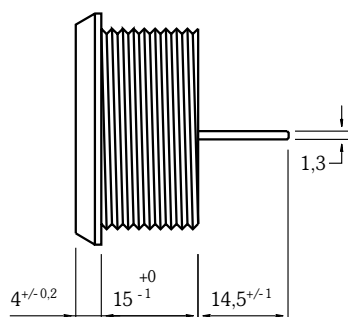

Note: the control pin (CP) is only installed in the multifunction buzzers. (see page 5)

Models SC, SCI, SW & SWP

Step 1,5 mm

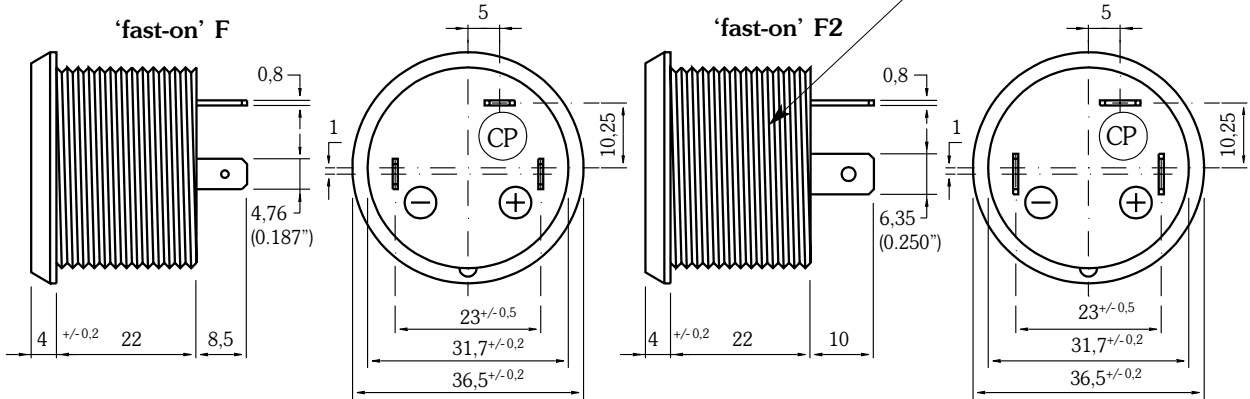

Models SU

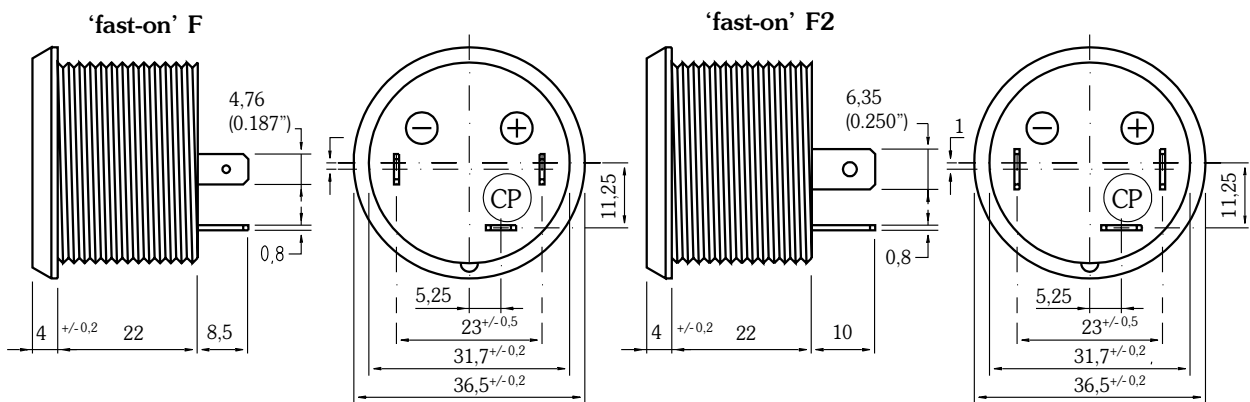

Model SP27

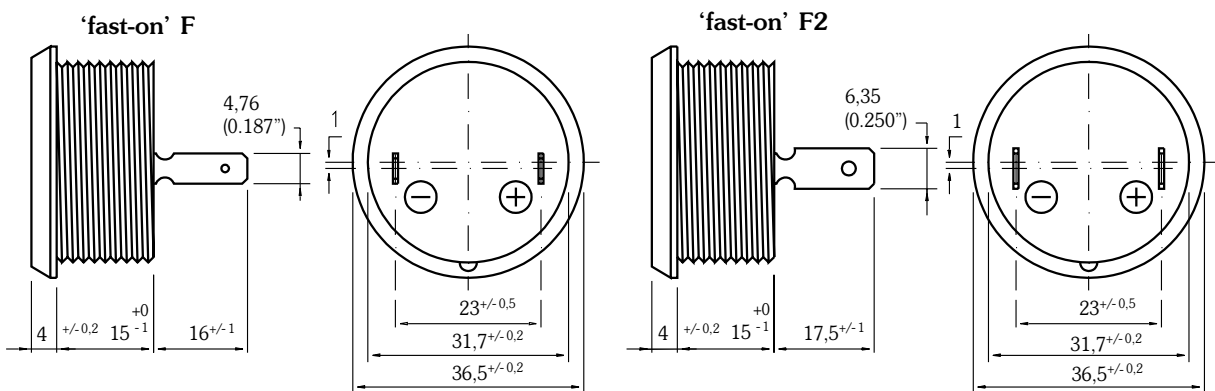

1.1.9. PRODUCT CODIFICATION

S	U(L)M	5	16	A	1	-	F**	M***
	CI	0.7*	15	B	5		F2	S
	W	2	35	C	↓		↓	MS***
	CR	↓	↓	↓			↓	
	C							
↓	U(L)C	Min. voltage	↓		Pulsation			
Sonitron	ULI	(Vdc)			1 = 1 Hz			
					5 = 5 Hz			
	↓		Max. voltage			'fast-on' terminals		M: Military
	C: continuous		(Vdc)			F: 4,76 mm		S: Square front
	U: universal			A: freq. 2500 Hz		F2: 6,35 mm		MS: Military & square front
	W: warbler			B: freq. 3500 Hz				
	I: intermittent			C: freq. 3000 Hz				
	CR: cricket & continue							
	M: multifunctional							
	L: Loud							

SP27: special model (see specifications, page 5)

*0.7: 0.7 Vdc minimum voltage of the SC 0715 BL

F** If the part number of the buzzer is without any terminal specifications, the model is standard delivered with round pins, diameter 1.5 mm. The fast-on terminals are available in two dimensions: F= 4.76 mm (0.187 inch) or F2 = 6.35 mm (0.250 inch).

M*** Military norm MIL STD 202

1.1.10. LIST OF AVAILABLE PRODUCT TYPES

The standard series offer the following models:

SC 235 A	SC 235 B	SC 0715 BL	SP27	SCI 535 A1	SCI 535 A5
SC 235 A-F	SC 235 B-F	SC 0715 BL-F	SP27-F	SCI 535 A1-F	SCI 535 A5-F
SC 235 A-F2	SC 235 B-F2	SC 0715 BL-F2	SP27-F2	SCI 535 A1-F2	SCI 535 A5-F2
SC 235 A-F-M	SC 235 B-F-M	SC 0715 BL-F-M	SP27-F-M	SCI 535 A1-F-M	SCI 535 A5-F-M
SC 235 A-F2-M	SC 235 B-F2-M	SC 0715 BL-F2-M	SP27-F2-M	SCI 535 A1-F2-M	SCI 535 A5-F2-M
SC 235 A-S	SC 235 B-S	SC 0715 BL-S	SP27-S	SCI 535 A1-S	SCI 535 A5-S
SC 235 A-F-S	SC 235 B-F-S	SC 0715 BL-F-S	SP27-F-S	SCI 535 A1-F-S	SCI 535 A5-F-S
SC 235 A-F2-S	SC 235 B-F2-S	SC 0715 BL-F2-S	SP27-F2-S	SCI 535 A1-F2-S	SCI 535 A5-F2-S
SC 235 A-F-MS	SC 235 B-F-MS	SC 0715 BL-F-MS	SP27-F-MS	SCI 535 A1-F-MS	SCI 535 A5-F-MS
SC 235 A-F2-MS	SC 235 B-F2-MS	SC 0715 BL-F2-MS	SP27-F2-MS	SCI 535 A1-F2-MS	SCI 535 A5-F2-MS
SCI 535 B1	SCI 535 B5	SCR 535 A	SCR 535 B	SUC 516 A	SUC 516 B
SCI 535 B1-F	SCI 535 B5-F	SCR 535 A-F	SCR 535 B-F	SUC 516 A-F	SUC 516 B-F
SCI 535 B1-F2	SCI 535 B5-F2	SCR 535 A-F2	SCR 535 B-F2	SUC 516 A-F2	SUC 516 B-F2
SCI 535 B1-F-M	SCI 535 B5-F-M	SCR 535 A-F-M	SCR 535 B-F-M	SUC 516 A-F-M	SUC 516 B-F-M
SCI 535 B1-F2-M	SCI 535 B5-F2-M	SCR 535 A-F2-M	SCR 535 B-F2-M	SUC 516 A-F2-M	SUC 516 B-F2-M
SCI 535 B1-S	SCI 535 B5-S	SCR 535 A-S	SCR 535 B-S	SUC 516 A-S	SUC 516 B-S
SCI 535 B1-F-S	SCI 535 B5-F-S	SCR 535 A-F-S	SCR 535 B-F-S	SUC 516 A-F-S	SUC 516 B-F-S
SCI 535 B1-F2-S	SCI 535 B5-F2-S	SCR 535 A-F2-S	SCR 535 B-F2-S	SUC 516 A-F2-S	SUC 516 B-F2-S
SCI 535 B1-F-MS	SCI 535 B5-F-MS	SCR 535 A-F-MS	SCR 535 B-F-MS	SUC 516 A-F-MS	SUC 516 B-F-MS
SCI 535 B1-F2-MS	SCI 535 B5-F2-MS	SCR 535 A-F2-MS	SCR 535 B-F2-MS	SUC 516 A-F2-MS	SUC 516 B-F2-MS
SULC 516 B	SUM 516 A1	SUM 516 A5	SULI 516 B1	SULI 516 B5	SULM 516 B1
SULC 516 B-F	SUM 516 A1-F	SUM 516 A5-F	SULI 516 B1-F	SULI 516 B5-F	SULM 516 B1-F
SULC 516 B-F2	SUM 516 A1-F2	SUM 516 A5-F2	SULI 516 B1-F2	SULI 516 B5-F2	SULM 516 B1-F2
SULC 516 B-F-M	SUM 516 A1-F-M	SUM 516 A5-F-M	SULI 516 B1-F-M	SULI 516 B5-F-M	SULM 516 B1-F-M
SULC 516 B-F2-M	SUM 516 A1-F2-M	SUM 516 A5-F2-M	SULI 516 B1-F2-M	SULI 516 B5-F2-M	SULM 516 B1-F2-M
SULC 516 B-S	SUM 516 A1-S	SUM 516 A5-S	SULI 516 B1-S	SULI 516 B5-S	SULM 516 B1-S
SULC 516 B-F-S	SUM 516 A1-F-S	SUM 516 A5-F-S	SULI 516 B1-F-S	SULI 516 B5-F-S	SULM 516 B1-F-S
SULC 516 B-F2-S	SUM 516 A1-F2-S	SUM 516 A5-F2-S	SULI 516 B1-F2-S	SULI 516 B5-F2-S	SULM 516 B1-F2-S
SULC 516 B-F-MS	SUM 516 A1-F-MS	SUM 516 A5-F-MS	SULI 516 B1-F-MS	SULI 516 B5-F-MS	SULM 516 B1-F-MS
SULC 516 B-F2-MS	SUM 516 A1-F2-MS	SUM 516 A5-F2-MS	SULI 516 B1-F2-MS	SULI 516 B5-F2-MS	SULM 516 B1-F2-MS
SULM 516 B5	SW 535 B	SC 515 C	SCI 515 C	SW 515 C	SWP 515 C
SULM 516 B5-F	SW 535 B-F	SC 515 C-F	SCI 515 C-F	SW 515 C-F	SWP 515 C-F
SULM 516 B5-F2	SW 535 B-F2	SC 515 C-F2	SCI 515 C-F2	SW 515 C-F2	SWP 515 C-F2
SULM 516 B5-F-M	SW 535 B-F-M	SC 515 C-F-M	SCI 515 C-F-M	SW 515 C-F-M	SWP 515 C-F-M
SULM 516 B5-F2-M	SW 535 B-F2-M	SC 515 C-F2-M	SCI 515 C-F2-M	SW 515 C-F2-M	SWP 515 C-F2-M
SULM 516 B5-S	SW 535 B-S	SC 515 C-S	SCI 515 C-S	SW 515 C-S	SWP 515 C-S
SULM 516 B5-F-S	SW 535 B-F-S	SC 515 C-F-S	SCI 515 C-F-S	SW 515 C-F-S	SWP 515 C-F-S
SULM 516 B5-F2-S	SW 535 B-F2-S	SC 515 C-F2-S	SCI 515 C-F2-S	SW 515 C-F2-S	SWP 515 C-F2-S
SULM 516 B5-F-MS	SW 535 B-F-MS	SC 515 C-F-MS	SCI 515 C-F-MS	SW 515 C-F-MS	SWP 515 C-F-MS
SULM 516 B5-F2-MS	SW 535 B-F2-MS	SC 515 C-F2-MS	SCI 515 C-F2-MS	SW 515 C-F2-MS	SWP 515 C-F2-MS

1.1.11. MILITARY MODELS

All standard models can be delivered in a military version. All military models have flame retardant ABS housings in olive green and fast-on terminals.

The military models guarantee a quality superior to the classic models. On top of the standard specifications, the military models are tested as follows:

Test	Method MIL STD202	Test conditions
Thermal Shock	107	A
Humidity	103	B
Salt Spray	101	A
Shock	213 B	H
Vibration	201 A	none
Thermal strength	211	A (10 Lbs, 2 cycles)

See also information about military norms in addendum.

1.1.12. MODELS ON REQUEST

The standard buzzers can be modified upon request in order to deliver a product, meeting the requirements of the customer's application.

- Upon special request all standard models are also available in GREY, BLACK or GREEN (khaki). Please add GREY, BLACK or GREEN to the part number if the required colour is different from the one specified as standard.
- For applications under aggressive humid conditions, models containing a piezo element covered with a protective coating are available. Add ACR to the part number. The protective coating gives a complementary assurance against smog; all standard models are perfectly waterproof (IP67) without the mentioned coating.
- Different pin terminal lengths, straight or bent can be custom manufactured.
- The frequency, indicated in the present catalogue, has an accuracy of ±15%. Standard buzzers with an improved frequency accuracy (up to ±2%) are available upon special customer request.

1.1.13. PACKAGING

All standard buzzers are packed in polystyrene boxes of 26.5 x 26.5 mm; 25 pieces per box.