



**HESTORE.HU**

elektronikai alkatrész áruház

**EN:** This Datasheet is presented by the manufacturer.

Please visit our website for pricing and availability at [www.hestore.hu](http://www.hestore.hu).

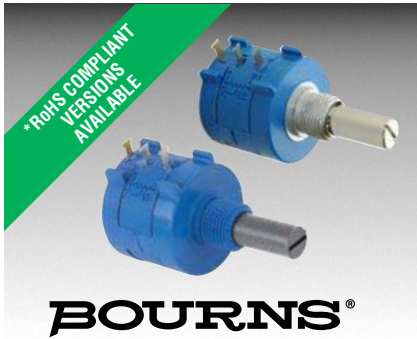

## Features

- Bushing mount
  - Optional AR pin feature
  - Plastic or metal shaft and bushings
  - Wirewound
  - Solder lugs or PC pins
  - Sealable (Full body seal)
- Designed for use in HMI applications

## 3590 - Precision Potentiometer

### Electrical Characteristics<sup>1</sup>

Standard Resistance Range.....	200 to 100 K ohms
Total Resistance Tolerance.....	±5 %
Independent Linearity.....	±0.25 %
Effective Electrical Angle.....	3600 ° +10 °, -0 °
Absolute Minimum Resistance.....	1 ohm or 0.1 % maximum (whichever is greater)
Noise.....	100 ohms ENR maximum
Dielectric Withstanding Voltage (MIL-STD-202, Method 301)	
Sea Level.....	1,500 VAC minimum
Power Rating (Voltage Limited By Power Dissipation or 450 VAC, Whichever is Less)	
+40 °C.....	2 watts
+125 °C.....	0 watt
Insulation Resistance (500 VDC).....	1,000 megohms minimum
Resolution.....	See recommended part numbers

### Environmental Characteristics<sup>1</sup>

Operating Temperature Range.....	-40 °C to +125 °C
Storage Temperature Range.....	-55 °C to +125 °C
Temperature Coefficient Over Storage Temperature Range <sup>2</sup> .....	±50 ppm/°C maximum/unit
Vibration.....	15 G
Wiper Bounce.....	0.1 millisecond maximum
Shock.....	50 G
Wiper Bounce.....	0.1 millisecond maximum
Load Life.....	1,000 hours, 2 watts
Total Resistance Shift.....	±2 % maximum
Rotational Life (No Load).....	1,000,000 shaft revolutions
Total Resistance Shift.....	±5 % maximum
Moisture Resistance (MIL-STD-202, Method 103, Condition B)	
Total Resistance Shift.....	±2 % maximum
IP Rating	
Sealed Versions (-3, -4, -7, and -8).....	IP 65
Unsealed Versions (-1 -2, -5, and -6).....	IP 40

### Mechanical Characteristics<sup>1</sup>

Stop Strength.....	45 N-cm (64 oz.-in.) minimum
Mechanical Angle.....	3600 ° +10 °, -0 °
Torque (Starting & Running).....	0.35 N-cm (0.5 oz.-in.) maximum (unsealed)
.....	1.1 N-cm (1.5 oz.-in.) maximum (sealed)
Mounting.....	55-80 N-cm (5-7 lb.-in.) (plastic)
.....	90-113 N-cm (8-10 in.-lb.) (metal)
Shaft Runout.....	0.13 mm (0.005 in.) T.I.R.
Lateral Runout.....	0.20 mm (0.008 in.) T.I.R.
Shaft End Play.....	0.25 mm (0.010 in.) T.I.R.
Shaft Radial Play.....	0.13 mm (0.005 in.) T.I.R.
Pilot Diameter Runout.....	0.08 mm (0.003 in.) T.I.R.
Backlash.....	1.0 ° maximum
Weight.....	Approximately 19 G
Terminals.....	Solder lugs or PC pins
Soldering Condition	
Manual Soldering.....	96.5Sn/3.0Ag/0.5Cu solid wire or no-clean rosin cored wire; 370 °C (700 °F) max. for 3 seconds
Wave Soldering.....	96.5Sn/3.0Ag/0.5Cu solder with no-clean flux; 260 °C (500 °F) max. for 5 seconds
Wash processes.....	Not recommended
Marking.....	Manufacturer's name and part number, resistance value and tolerance, linearity tolerance, wiring diagram, and date code.
Ganging (Multiple Section Potentiometers).....	1 cup maximum
Hardware.....	One lockwasher and one mounting nut is shipped with each potentiometer.

NOTE: For Anti-rotation pin add 91 after configuration dash number. Example: -2 becomes -291 to add AR pin.

<sup>1</sup>At room ambient: +25 °C nominal and 50 % relative humidity nominal, except as noted.

<sup>2</sup>Consult manufacturer for complete specification details for resistances below 1k ohms.

### Recommended Part Numbers

(Printed Circuit)	(Solder Lug)	(Solder Lug)	Resistance (Ω)	Resolution (%)
3590P-2-102L	<b>3590S-2-102L</b>	3590S-1-102L	1,000	.029
3590P-2-202L	<b>3590S-2-202L</b>	3590S-1-202L	2,000	.023
3590P-2-502L	<b>3590S-2-502L</b>	3590S-1-502L	5,000	.025
3590P-2-103L	<b>3590S-2-103L</b>	3590S-1-103L	10,000	.020
3590P-2-203L	<b>3590S-2-203L</b>	3590S-1-203L	20,000	.019
3590P-2-503L	<b>3590S-2-503L</b>	3590S-1-503L	50,000	.013
3590P-2-104L	<b>3590S-2-104L</b>	3590S-1-104L	100,000	.009

**BOLDFACE LISTINGS ARE IN STOCK AND READILY AVAILABLE THROUGH DISTRIBUTION.**

FOR OTHER OPTIONS CONSULT FACTORY.

ROHS IDENTIFIER:

L = COMPLIANT

BLANK = NON-COMPLIANT

\*RoHS Directive 2002/95/EC Jan 27 2003 including Annex Specifications are subject to change without notice.

Customers should verify actual device performance in their specific applications.

# 3590 - Precision Potentiometer

**BOURNS®**

## Product Dimensions

### -1, -3, -5, -7 Configurations

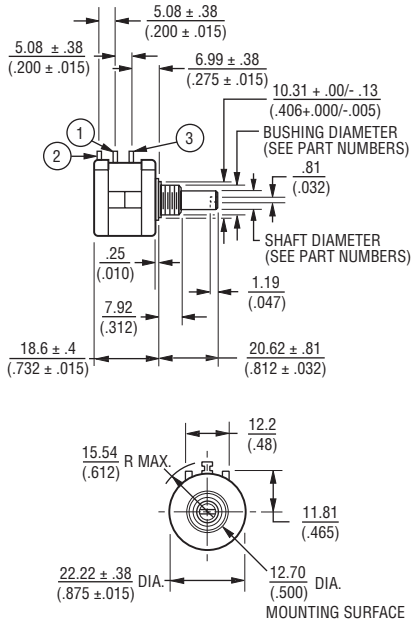

### -2, -4, -6, -8 Configurations

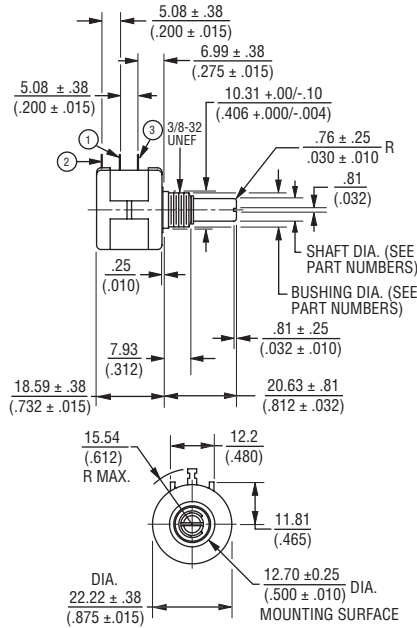

## Panel Thickness Dimensions

### (For Bushing Mount Only)

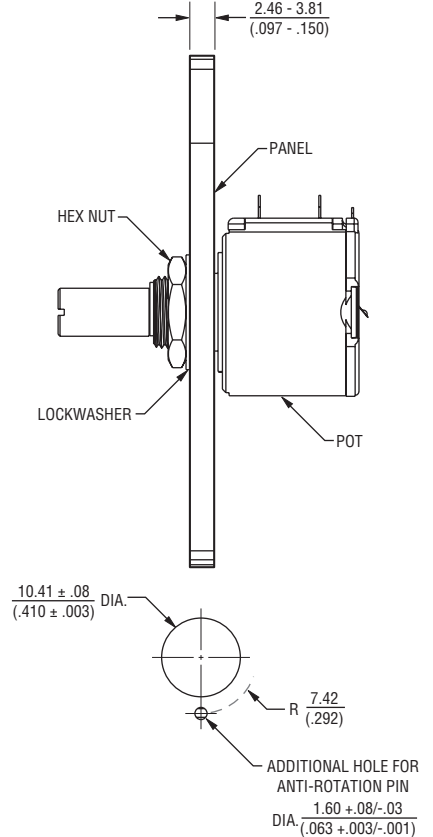

## Recommended PCB Layout

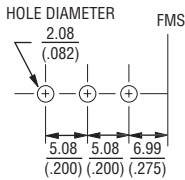

## Schematic

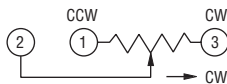

TOLERANCES: EXCEPT WHERE NOTED  
 DECIMALS: .XX ±  $\frac{.508}{.02}$ , .XXX ±  $\frac{.127}{.005}$   
 FRACTIONS: ±1/64  
 DIMENSIONS:  $\frac{MM}{(IN.)}$

## Terminal Styles

### "P" Terminal Style

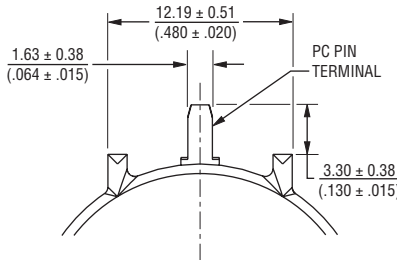

### "S" Terminal Style

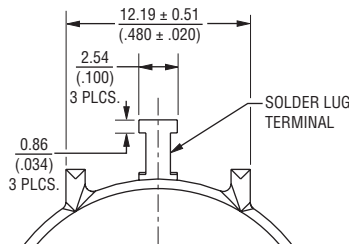

## Shaft & Bushing Configurations

- (Bushing - DxL, Shaft - D):
- (-1) Plastic Bushing (3/8 " x 5/16 ") and Shaft (.2480 + .001, - .002)
  - (-2) Metal Bushing (3/8 " x 5/16 ") and Shaft (.2497 + .0000, - .0009)
  - (-3) Sealed, Plastic Bushing (3/8 " x 5/16 ") and Shaft (.2480 + .001, - .002)
  - (-4) Sealed, Metal Bushing (3/8 " x 5/16 ") and Shaft (.2497 + .0000, - .0009)
  - (-5) Metric, Plastic Bushing (9 mm x 7.94 mm) and Shaft (6 mm + 0, - .076 mm)
  - (-6) Metric, Metal Bushing (9 mm x 7.94 mm) and Shaft (6 mm + 0, - .023 mm)
  - (-7) Metric, Sealed, Plastic Bushing (9 mm x 7.94 mm) and Shaft (6 mm + 0, - .076 mm)
  - (-8) Metric, Sealed, Metal Bushing (9 mm x 7.94 mm) and Shaft (6 mm + 0, - .023 mm)

REV. 09/10

"Hybritron" is a registered trademark of Hybritron, Inc.  
 Specifications are subject to change without notice.  
 Customers should verify actual device performance in their specific applications.