



HESTORE.HU

elektronikai alkatrész áruház

EN: This Datasheet is presented by the manufacturer.

Please visit our website for pricing and availability at www.hestore.hu.

DATA SHEET



PCF8591

8-bit A/D and D/A converter

Product specification
Supersedes data of 2001 Dec 13

2003 Jan 27

8-bit A/D and D/A converter**PCF8591**

CONTENTS

1	FEATURES
2	APPLICATIONS
3	GENERAL DESCRIPTION
4	ORDERING INFORMATION
5	BLOCK DIAGRAM
6	PINNING
7	FUNCTIONAL DESCRIPTION
7.1	Addressing
7.2	Control byte
7.3	D/A conversion
7.4	A/D conversion
7.5	Reference voltage
7.6	Oscillator
8	CHARACTERISTICS OF THE I ² C-BUS
8.1	Bit transfer
8.2	Start and stop conditions
8.3	System configuration
8.4	Acknowledge
8.5	I ² C-bus protocol
9	LIMITING VALUES
10	HANDLING
11	DC CHARACTERISTICS
12	D/A CHARACTERISTICS
13	A/D CHARACTERISTICS
14	AC CHARACTERISTICS
15	APPLICATION INFORMATION
16	PACKAGE OUTLINES
17	SOLDERING
17.1	Introduction to soldering through-hole mount packages
17.2	Soldering by dipping or by solder wave
17.3	Manual soldering
17.4	Suitability of through-hole mount IC packages for dipping and wave soldering methods
18	DATA SHEET STATUS
19	DEFINITIONS
20	DISCLAIMERS
21	PURCHASE OF PHILIPS I ² C COMPONENTS

8-bit A/D and D/A converter

PCF8591

1 FEATURES

- Single power supply
- Operating supply voltage 2.5 V to 6 V
- Low standby current
- Serial input/output via I²C-bus
- Address by 3 hardware address pins
- Sampling rate given by I²C-bus speed
- 4 analog inputs programmable as single-ended or differential inputs
- Auto-incremented channel selection
- Analog voltage range from V_{SS} to V_{DD}
- On-chip track and hold circuit
- 8-bit successive approximation A/D conversion
- Multiplying DAC with one analog output.

2 APPLICATIONS

- Closed loop control systems
- Low power converter for remote data acquisition
- Battery operated equipment
- Acquisition of analog values in automotive, audio and TV applications.

4 ORDERING INFORMATION

TYPE NUMBER	PACKAGE		
	NAME	DESCRIPTION	VERSION
PCF8591P	DIP16	plastic dual in-line package; 16 leads (300 mil)	SOT38-4
PCF8591T	SO16	plastic small outline package; 16 leads; body width 7.5 mm	SOT162-1

**3 GENERAL DESCRIPTION**

The PCF8591 is a single-chip, single-supply low power 8-bit CMOS data acquisition device with four analog inputs, one analog output and a serial I²C-bus interface. Three address pins A0, A1 and A2 are used for programming the hardware address, allowing the use of up to eight devices connected to the I²C-bus without additional hardware. Address, control and data to and from the device are transferred serially via the two-line bidirectional I²C-bus.

The functions of the device include analog input multiplexing, on-chip track and hold function, 8-bit analog-to-digital conversion and an 8-bit digital-to-analog conversion. The maximum conversion rate is given by the maximum speed of the I²C-bus.

8-bit A/D and D/A converter

PCF8591

5 BLOCK DIAGRAM

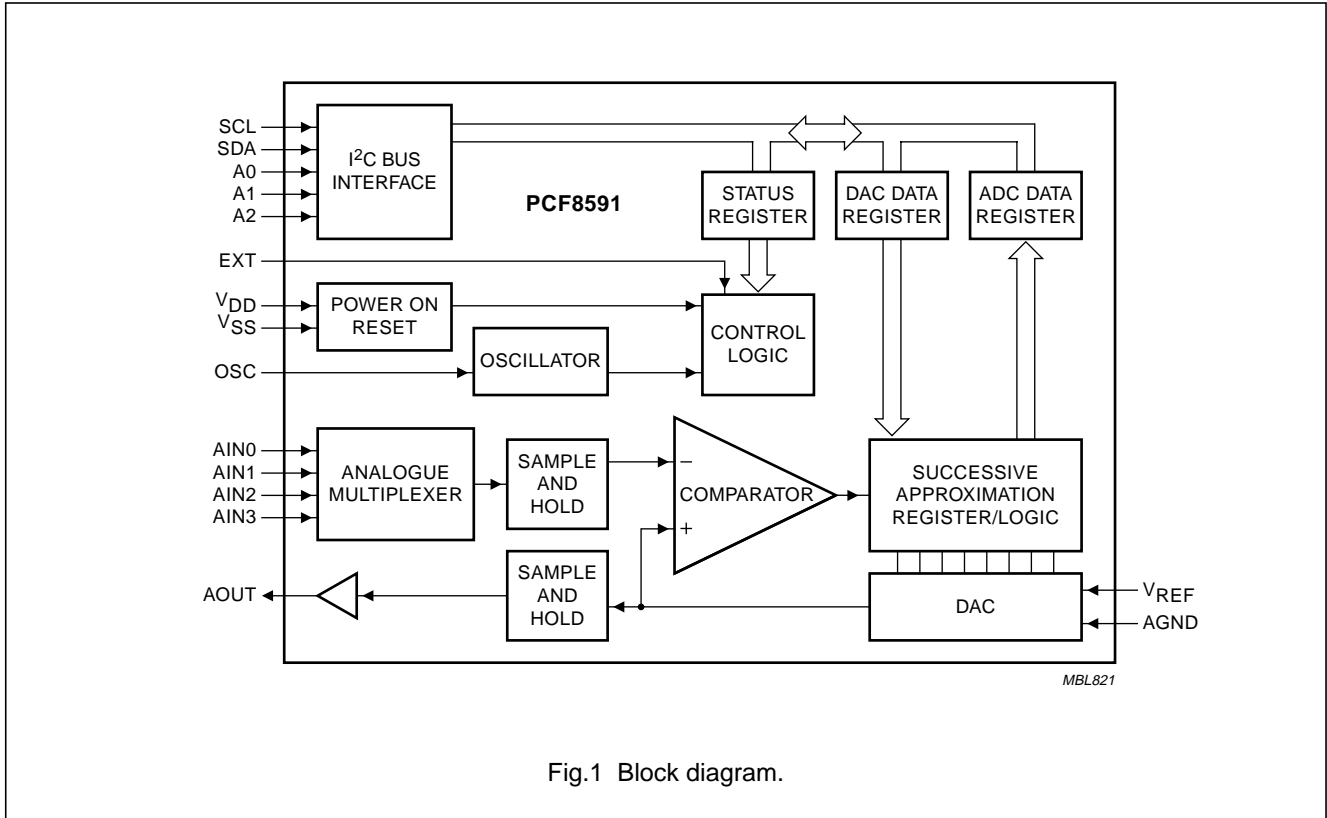

6 PINNING

SYMBOL	PIN	DESCRIPTION
AIN0	1	analog inputs (A/D converter)
AIN1	2	
AIN2	3	
AIN3	4	
A0	5	hardware address
A1	6	
A2	7	
V _{SS}	8	negative supply voltage
SDA	9	I ² C-bus data input/output
SCL	10	I ² C-bus clock input
OSC	11	oscillator input/output
EXT	12	external/internal switch for oscillator input
AGND	13	analog ground
V _{REF}	14	voltage reference input
AOUT	15	analog output (D/A converter)
V _{DD}	16	positive supply voltage

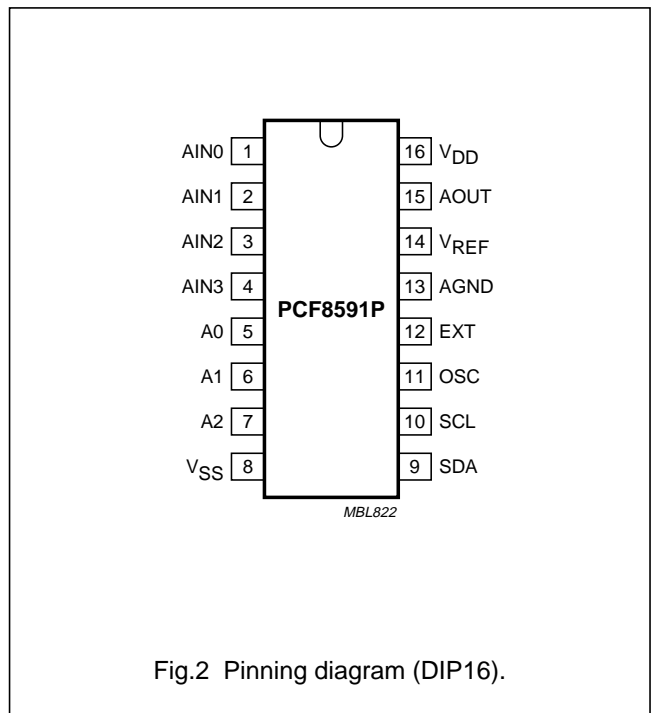

8-bit A/D and D/A converter

PCF8591

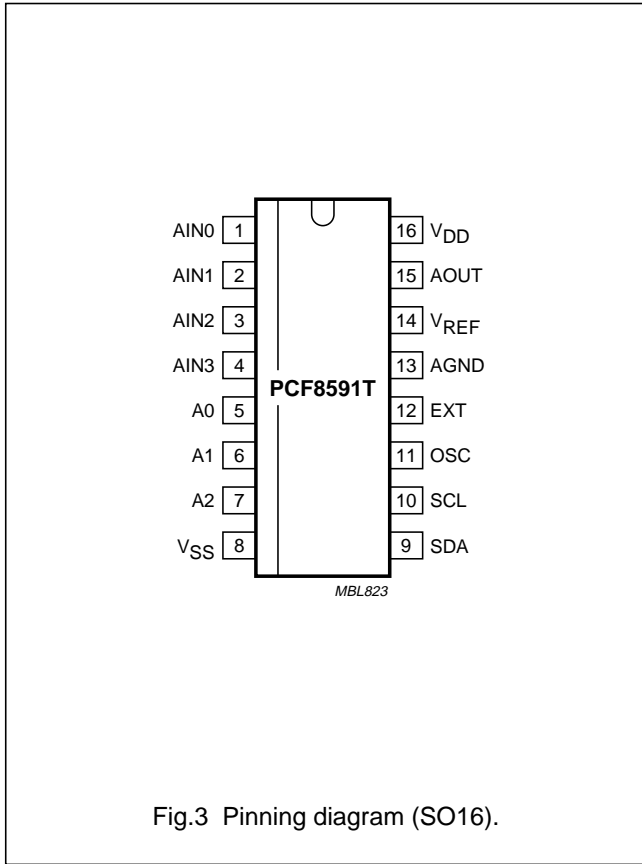

Fig.3 Pinning diagram (SO16).

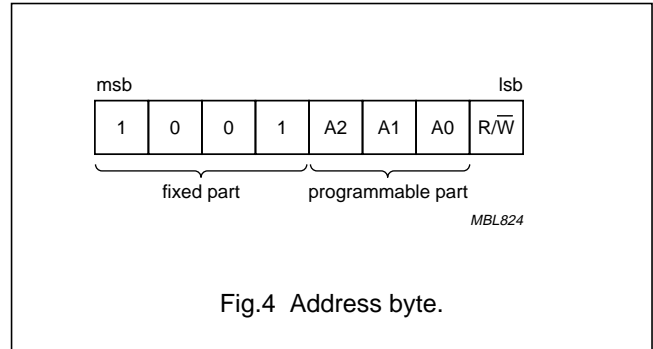

Fig.4 Address byte.

7 FUNCTIONAL DESCRIPTION

7.1 Addressing

Each PCF8591 device in an I²C-bus system is activated by sending a valid address to the device. The address consists of a fixed part and a programmable part. The programmable part must be set according to the address pins A0, A1 and A2. The address always has to be sent as the first byte after the start condition in the I²C-bus protocol. The last bit of the address byte is the read/write-bit which sets the direction of the following data transfer (see Figs 4, 16 and 17).

7.2 Control byte

The second byte sent to a PCF8591 device will be stored in its control register and is required to control the device function. The upper nibble of the control register is used for enabling the analog output, and for programming the analog inputs as single-ended or differential inputs. The lower nibble selects one of the analog input channels defined by the upper nibble (see Fig.5). If the auto-increment flag is set, the channel number is incremented automatically after each A/D conversion.

If the auto-increment mode is desired in applications where the internal oscillator is used, the analog output enable flag in the control byte (bit 6) should be set. This allows the internal oscillator to run continuously, thereby preventing conversion errors resulting from oscillator start-up delay. The analog output enable flag may be reset at other times to reduce quiescent power consumption.

The selection of a non-existing input channel results in the highest available channel number being allocated. Therefore, if the auto-increment flag is set, the next selected channel will be always channel 0. The most significant bits of both nibbles are reserved for future functions and have to be set to logic 0. After a Power-on reset condition all bits of the control register are reset to logic 0. The D/A converter and the oscillator are disabled for power saving. The analog output is switched to a high-impedance state.

8-bit A/D and D/A converter

PCF8591

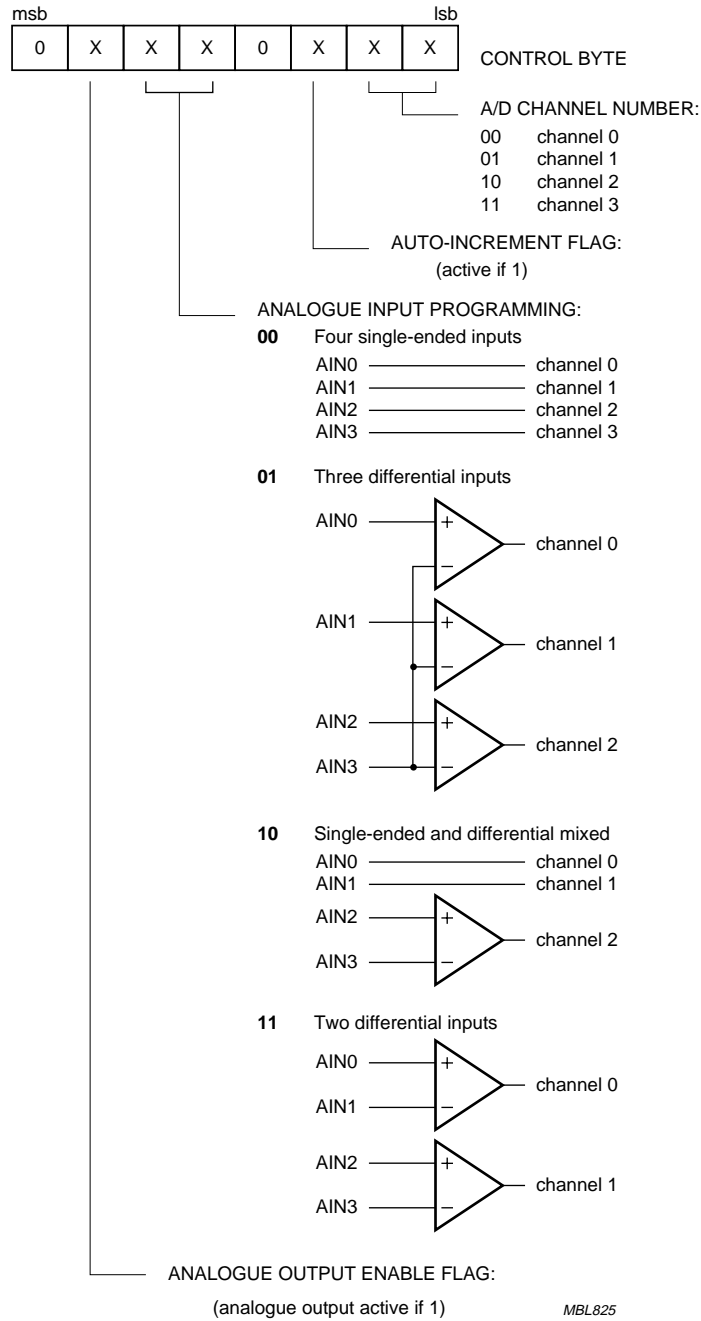

Fig.5 Control byte.

8-bit A/D and D/A converter

PCF8591

7.3 D/A conversion

The third byte sent to a PCF8591 device is stored in the DAC data register and is converted to the corresponding analog voltage using the on-chip D/A converter. This D/A converter consists of a resistor divider chain connected to the external reference voltage with 256 taps and selection switches. The tap-decoder switches one of these taps to the DAC output line (see Fig.6).

The analog output voltage is buffered by an auto-zeroed unity gain amplifier. This buffer amplifier may be switched on or off by setting the analog output enable flag of the

control register. In the active state the output voltage is held until a further data byte is sent.

The on-chip D/A converter is also used for successive approximation A/D conversion. In order to release the DAC for an A/D conversion cycle the unity gain amplifier is equipped with a track and hold circuit. This circuit holds the output voltage while executing the A/D conversion.

The output voltage supplied to the analog output AOUT is given by the formula shown in Fig.7. The waveforms of a D/A conversion sequence are shown in Fig.8.

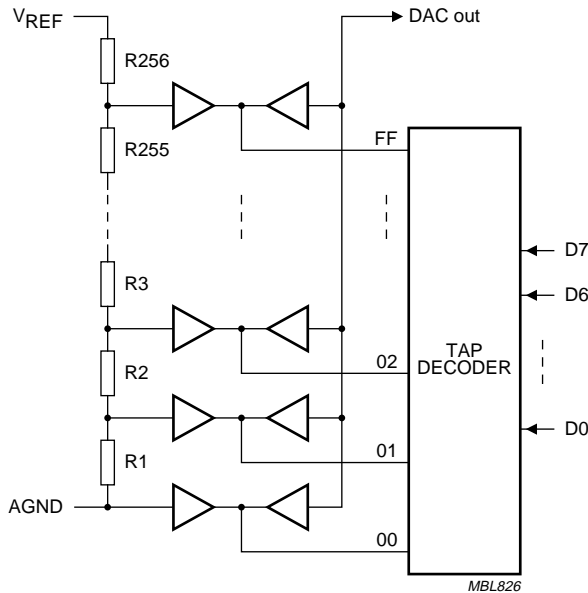
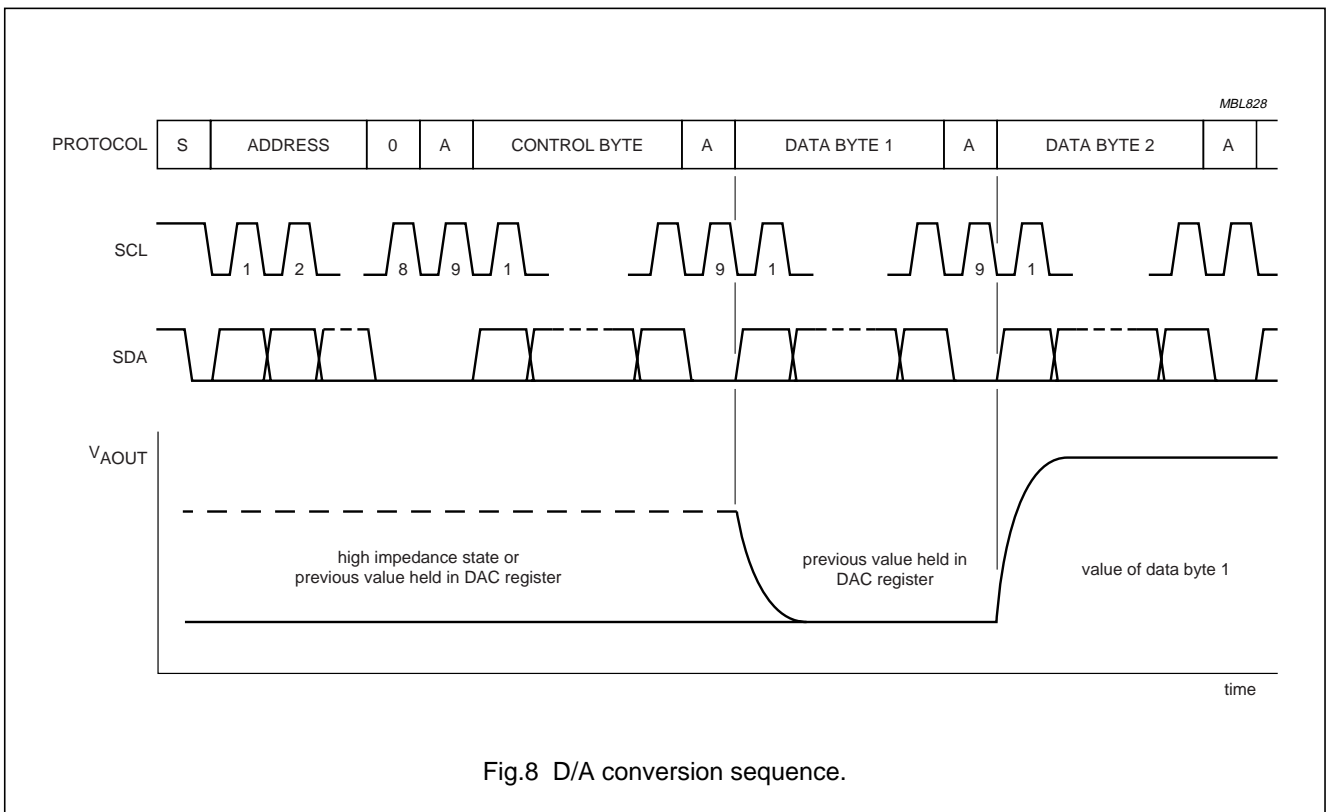
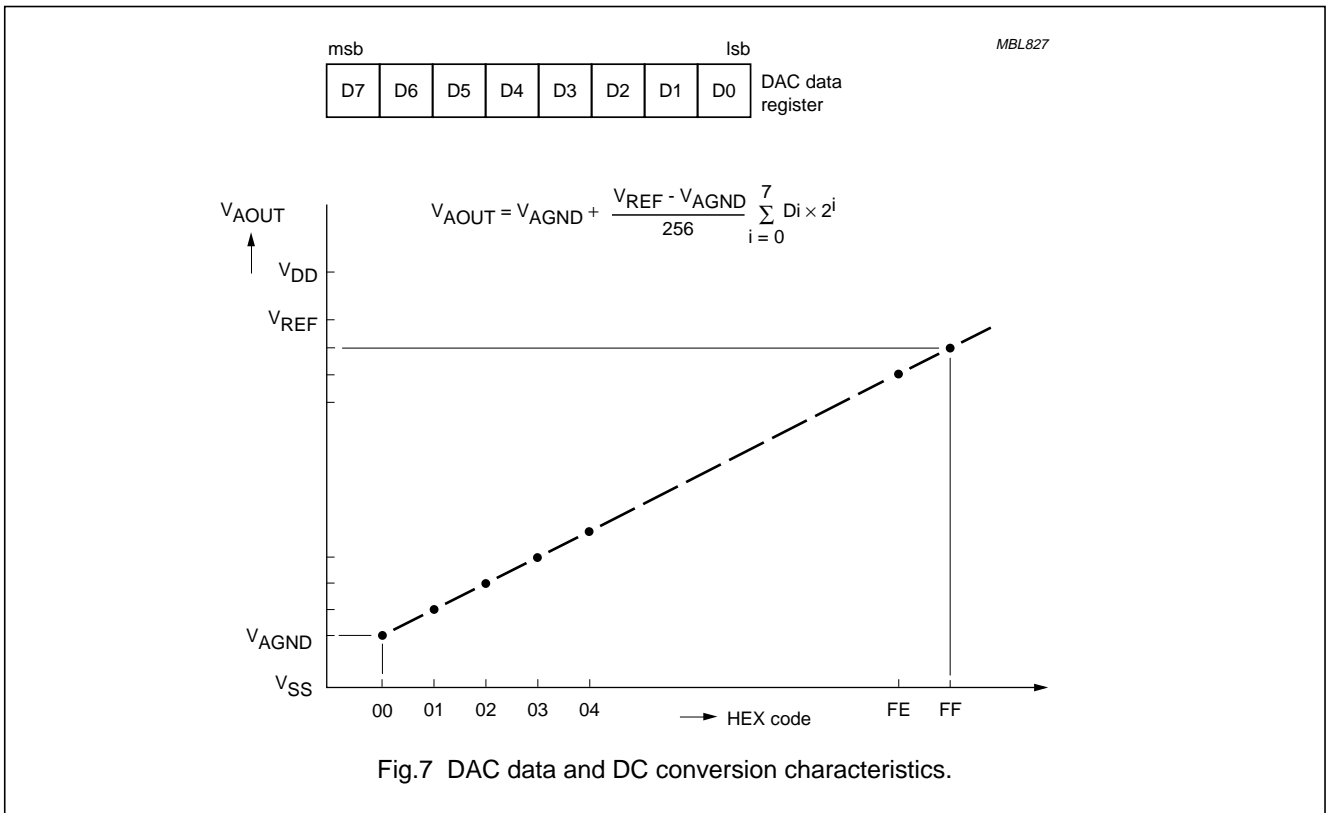

Fig.6 DAC resistor divider chain.

8-bit A/D and D/A converter

PCF8591



8-bit A/D and D/A converter

PCF8591

7.4 A/D conversion

The A/D converter makes use of the successive approximation conversion technique. The on-chip D/A converter and a high-gain comparator are used temporarily during an A/D conversion cycle.

An A/D conversion cycle is always started after sending a valid read mode address to a PCF8591 device. The A/D conversion cycle is triggered at the trailing edge of the acknowledge clock pulse and is executed while transmitting the result of the previous conversion (see Fig.9).

Once a conversion cycle is triggered an input voltage sample of the selected channel is stored on the chip and is

converted to the corresponding 8-bit binary code. Samples picked up from differential inputs are converted to an 8-bit twos complement code (see Figs 10 and 11).

The conversion result is stored in the ADC data register and awaits transmission. If the auto-increment flag is set the next channel is selected.

The first byte transmitted in a read cycle contains the conversion result code of the previous read cycle. After a Power-on reset condition the first byte read is a hexadecimal 80. The protocol of an I²C-bus read cycle is shown in Chapter 8, Figs 16 and 17.

The maximum A/D conversion rate is given by the actual speed of the I²C-bus.

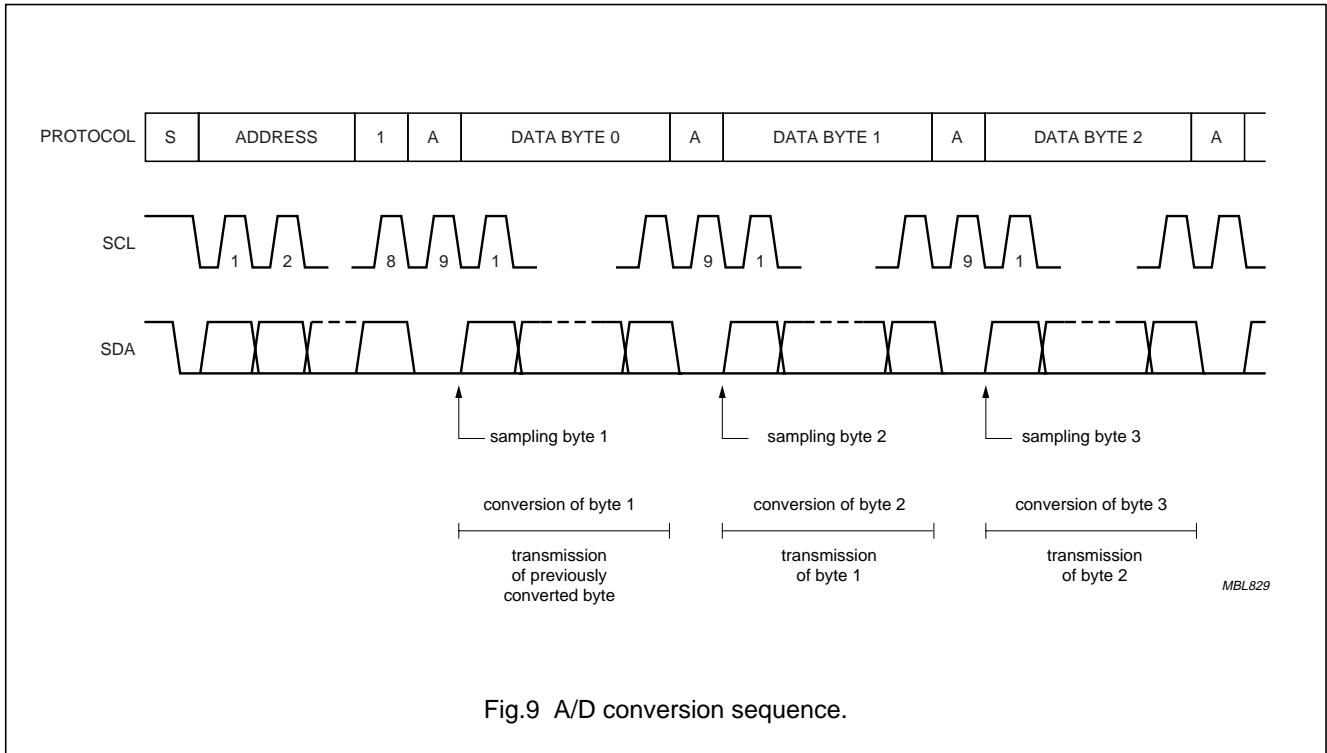
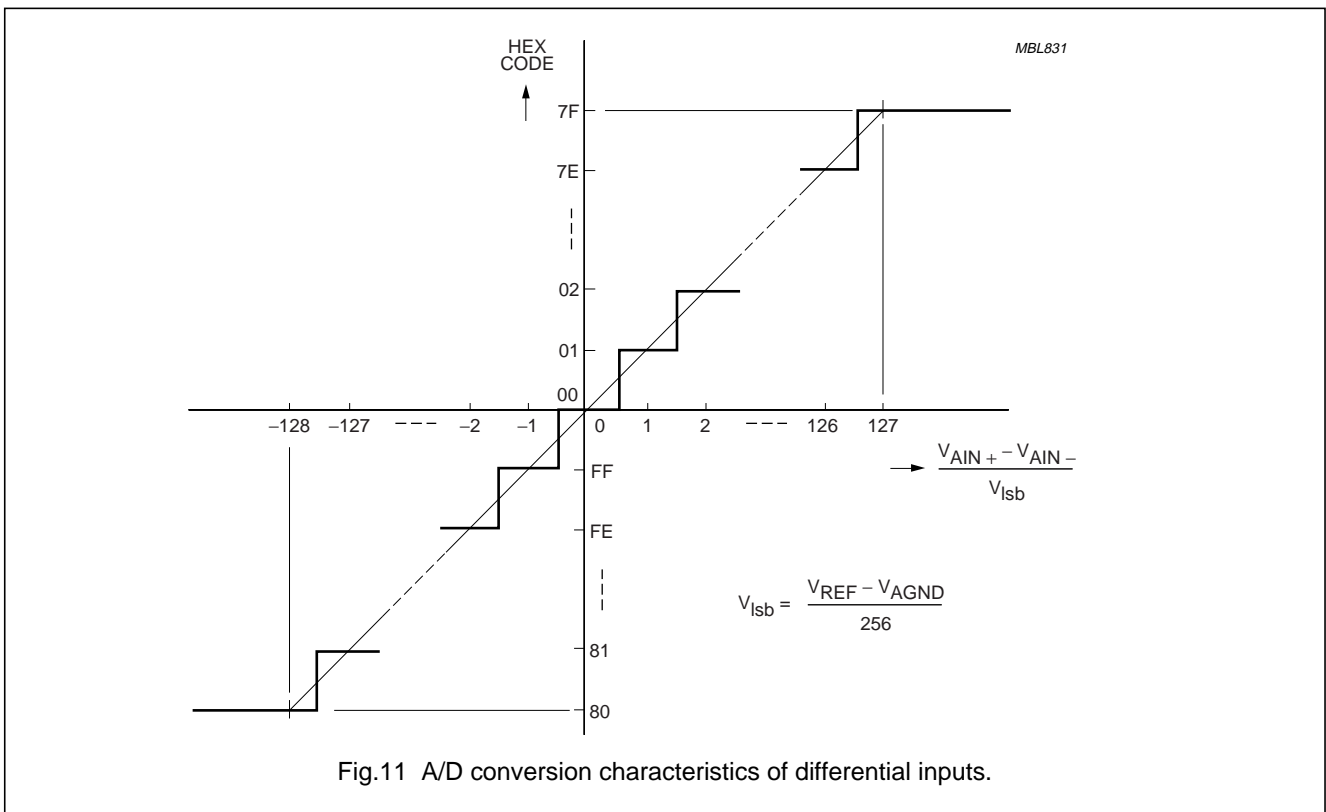
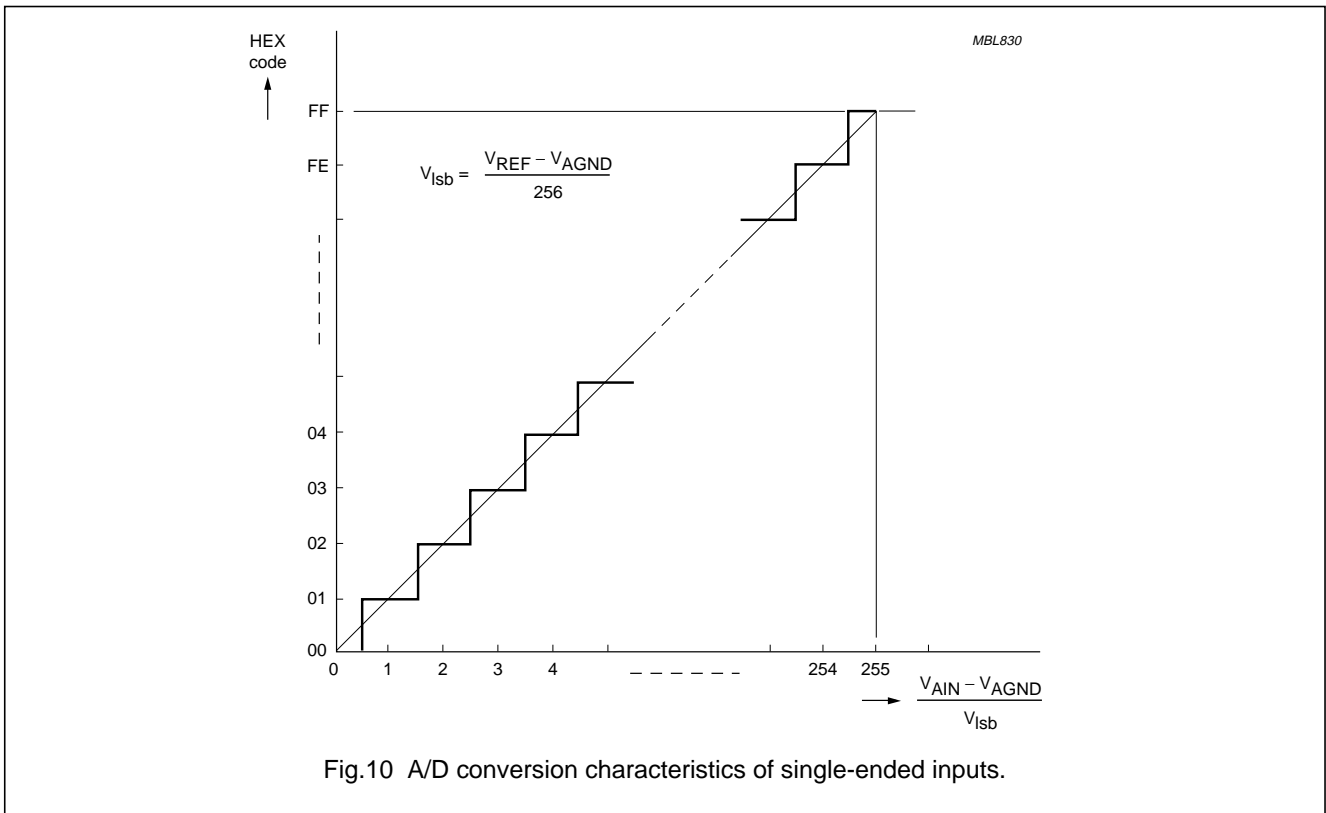

Fig.9 A/D conversion sequence.

8-bit A/D and D/A converter

PCF8591



8-bit A/D and D/A converter

PCF8591

7.5 Reference voltage

For the D/A and A/D conversion either a stable external voltage reference or the supply voltage has to be applied to the resistor divider chain (pins V_{REF} and AGND). The AGND pin has to be connected to the system analog ground and may have a DC off-set with reference to V_{SS} .

A low frequency may be applied to the V_{REF} and AGND pins. This allows the use of the D/A converter as a one-quadrant multiplier; see Chapter 15 and Fig.7.

The A/D converter may also be used as a one or two quadrant analog divider. The analog input voltage is divided by the reference voltage. The result is converted to a binary code. In this application the user has to keep the reference voltage stable during the conversion cycle.

7.6 Oscillator

An on-chip oscillator generates the clock signal required for the A/D conversion cycle and for refreshing the auto-zeroed buffer amplifier. When using this oscillator the EXT pin has to be connected to V_{SS} . At the OSC pin the oscillator frequency is available.

If the EXT pin is connected to V_{DD} the oscillator output OSC is switched to a high-impedance state allowing the user to feed an external clock signal to OSC.

8-bit A/D and D/A converter

PCF8591

8 CHARACTERISTICS OF THE I²C-BUS

The I²C-bus is for bidirectional, two-line communication between different ICs or modules. The two lines are a serial data line (SDA) and a serial clock line (SCL). Both lines must be connected to a positive supply via a pull-up resistor. Data transfer may be initiated only when the bus is not busy.

8.1 Bit transfer

One data bit is transferred during each clock pulse. The data on the SDA line must remain stable during the HIGH period of the clock pulse as changes in the data line at this time will be interpreted as a control signal.

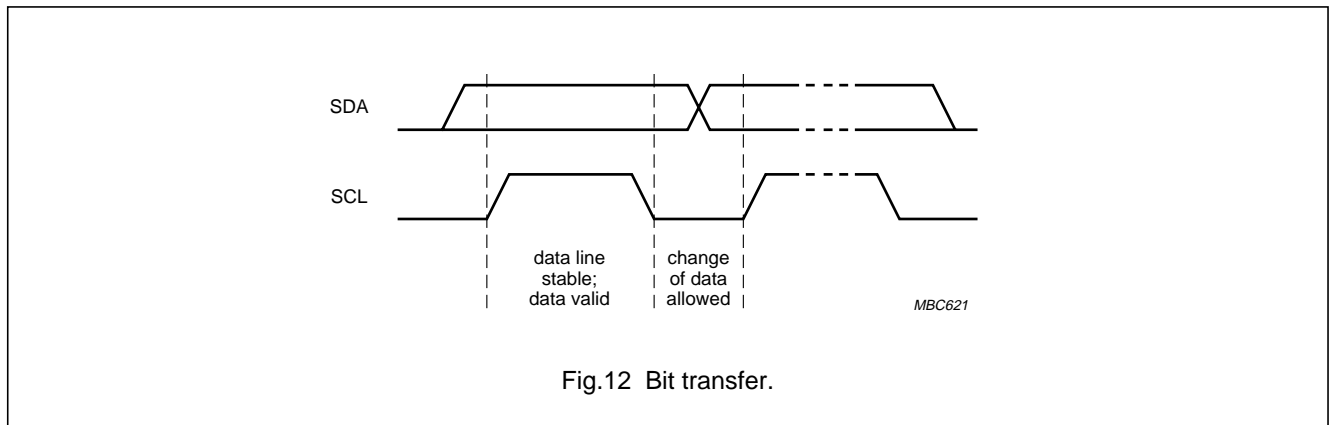

Fig.12 Bit transfer.

8.2 Start and stop conditions

Both data and clock lines remain HIGH when the bus is not busy. A HIGH-to-LOW transition of the data line, while the clock is HIGH, is defined as the start condition (S). A LOW-to-HIGH transition of the data line while the clock is HIGH, is defined as the stop condition (P).

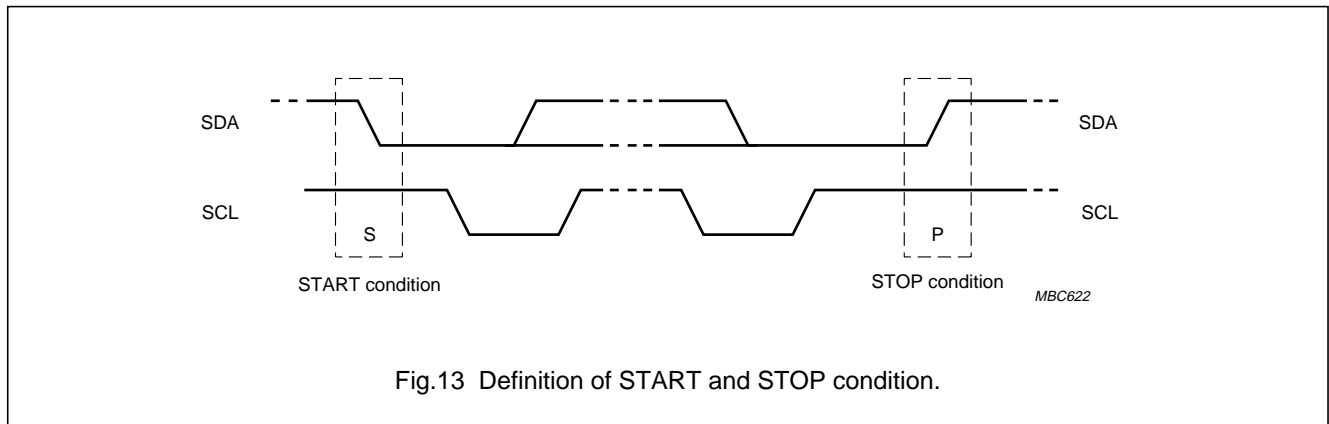

Fig.13 Definition of START and STOP condition.

8-bit A/D and D/A converter

PCF8591

8.3 System configuration

A device generating a message is a 'transmitter', a device receiving a message is the 'receiver'. The device that controls the message is the 'master' and the devices which are controlled by the master are the 'slaves'.

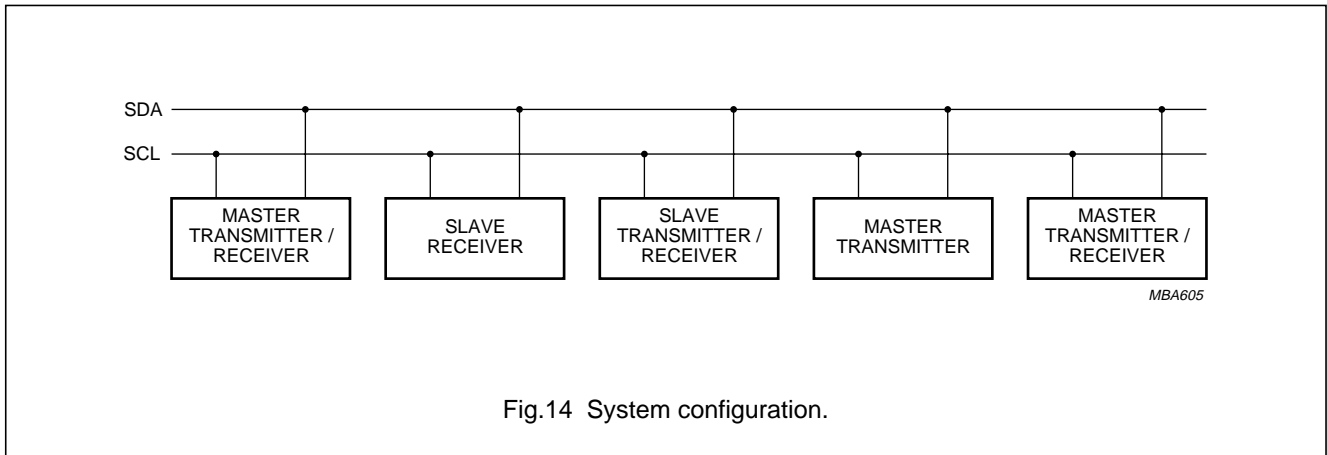

Fig.14 System configuration.

8.4 Acknowledge

The number of data bytes transferred between the start and stop conditions from transmitter to receiver is not limited. Each data byte of eight bits is followed by one acknowledge bit. The acknowledge bit is a HIGH level put on the bus by the transmitter whereas the master also generates an extra acknowledge related clock pulse. A slave receiver which is addressed must generate an acknowledge after the reception of each byte. Also a master must generate an acknowledge after the reception of each byte that has been clocked out of the slave transmitter. The device that acknowledges has to pull down the SDA line during the acknowledge clock pulse, so that the SDA line is stable LOW during the HIGH period of the acknowledge related clock pulse. A master receiver must signal an end of data to the transmitter by **not** generating an acknowledge on the last byte that has been clocked out of the slave. In this event the transmitter must leave the data line HIGH to enable the master to generate a stop condition.

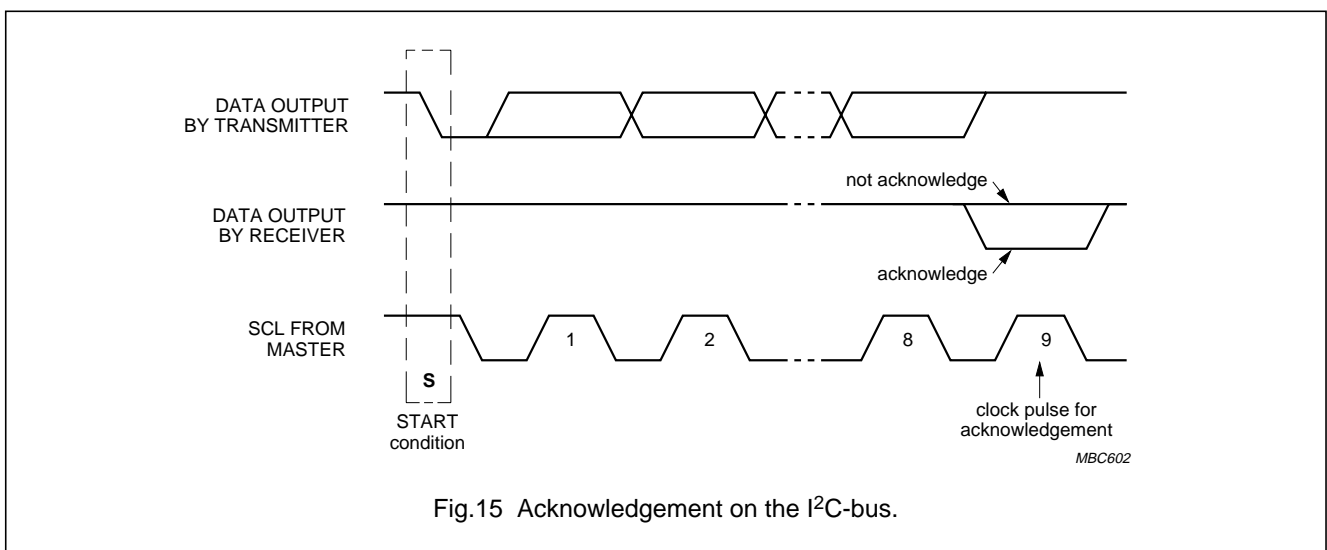

Fig.15 Acknowledgement on the I²C-bus.

8-bit A/D and D/A converter

PCF8591

8.5 I²C-bus protocol

After a start condition a valid hardware address has to be sent to a PCF8591 device. The read/write bit defines the direction of the following single or multiple byte data transfer. For the format and the timing of the start condition (S), the stop condition (P) and the acknowledge bit (A) refer to the I²C-bus characteristics. In the write mode a data transfer is terminated by sending either a stop condition or the start condition of the next data transfer.

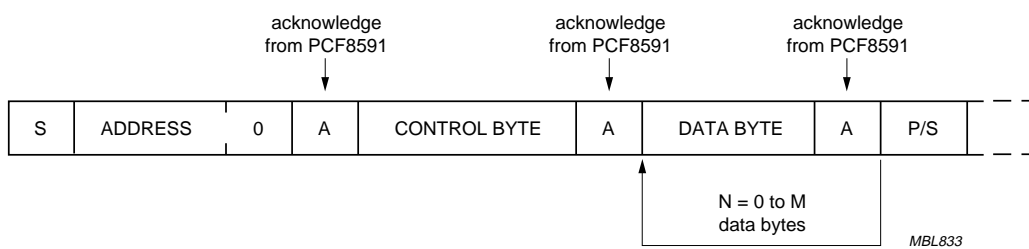

Fig.16 Bus protocol for write mode, D/A conversion.

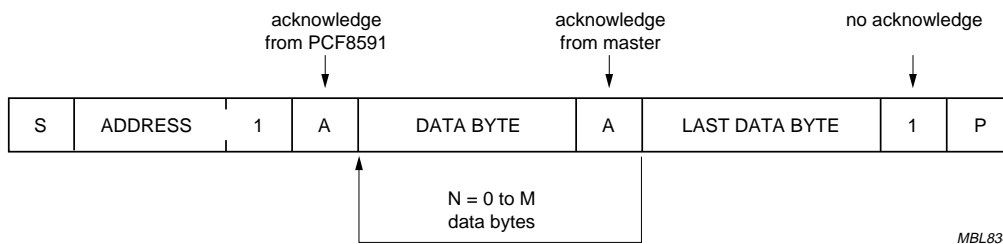

Fig.17 Bus protocol for read mode, A/D conversion.

8-bit A/D and D/A converter

PCF8591

9 LIMITING VALUES

In accordance with the Absolute Maximum Rating System (IEC 60134).

SYMBOL	PARAMETER	MIN.	MAX.	UNIT
V_{DD}	supply voltage (pin 16)	-0.5	+8.0	V
V_I	input voltage (any input)	-0.5	$V_{DD} + 0.5$	V
I_I	DC input current	-	± 10	mA
I_O	DC output current	-	± 20	mA
I_{DD}, I_{SS}	V_{DD} or V_{SS} current	-	± 50	mA
P_{tot}	total power dissipation per package	-	300	mW
P_O	power dissipation per output	-	100	mW
T_{amb}	operating ambient temperature	-40	+85	°C
T_{stg}	storage temperature	-65	+150	°C

10 HANDLING

Inputs and outputs are protected against electrostatic discharge in normal handling. However it is good practice to take normal precautions appropriate to handling MOS devices (see "Handling MOS devices").

8-bit A/D and D/A converter

PCF8591

11 DC CHARACTERISTICS

$V_{DD} = 2.5 \text{ V to } 6 \text{ V}$; $V_{SS} = 0 \text{ V}$; $T_{amb} = -40 \text{ }^\circ\text{C to } +85 \text{ }^\circ\text{C}$ unless otherwise specified.

SYMBOL	PARAMETER	CONDITIONS	MIN.	TYP.	MAX.	UNIT
Supply						
V_{DD}	supply voltage (operating)		2.5	–	6.0	V
I_{DD}	supply current					
	standby	$V_I = V_{SS}$ or V_{DD} ; no load	–	1	15	μA
	operating, AOUT off	$f_{SCL} = 100 \text{ kHz}$	–	125	250	μA
	operating, AOUT active	$f_{SCL} = 100 \text{ kHz}$	–	0.45	1.0	mA
V_{POR}	Power-on reset level	note 1	0.8	–	2.0	V
Digital inputs/output: SCL, SDA, A0, A1, A2						
V_{IL}	LOW level input voltage		0	–	$0.3 \times V_{DD}$	V
V_{IH}	HIGH level input voltage		$0.7 \times V_{DD}$	–	V_{DD}	V
I_L	leakage current					
	A0, A1, A2	$V_I = V_{SS}$ to V_{DD}	–250	–	+250	nA
	SCL, SDA	$V_I = V_{SS}$ to V_{DD}	–1	–	+1	μA
C_i	input capacitance		–	–	5	pF
I_{OL}	LOW level SDA output current	$V_{OL} = 0.4 \text{ V}$	3.0	–	–	mA
Reference voltage inputs						
V_{REF}	reference voltage	$V_{REF} > V_{AGND}$; note 2	$V_{SS} + 1.6$	–	V_{DD}	V
V_{AGND}	analog ground voltage	$V_{REF} > V_{AGND}$; note 2	V_{SS}	–	$V_{DD} - 0.8$	V
I_{LI}	input leakage current		–250	–	+250	nA
R_{REF}	input resistance	pins V_{REF} and $AGND$	–	100	–	$\text{k}\Omega$
Oscillator: OSC, EXT						
I_{LI}	input leakage current		–	–	250	nA
f_{OSC}	oscillator frequency		0.75	–	1.25	MHz

Notes

1. The power on reset circuit resets the I²C-bus logic when V_{DD} is less than V_{POR} .
2. A further extension of the range is possible, if the following conditions are fulfilled:

$$\frac{V_{REF} + V_{AGND}}{2} \geq 0.8 \text{ V}, V_{DD} - \frac{V_{REF} + V_{AGND}}{2} \geq 0.4 \text{ V}$$

8-bit A/D and D/A converter

PCF8591

12 D/A CHARACTERISTICS

$V_{DD} = 5.0\text{ V}$; $V_{SS} = 0\text{ V}$; $V_{REF} = 5.0\text{ V}$; $V_{AGND} = 0\text{ V}$; $R_L = 10\text{ k}\Omega$; $C_L = 100\text{ pF}$; $T_{amb} = -40\text{ }^\circ\text{C}$ to $+85\text{ }^\circ\text{C}$ unless otherwise specified.

SYMBOL	PARAMETER	CONDITIONS	MIN.	TYP.	MAX.	UNIT
Analog output						
V_{OA}	output voltage	no resistive load	V_{SS}	–	V_{DD}	V
		$R_L = 10\text{ k}\Omega$	V_{SS}	–	$0.9 \times V_{DD}$	V
I_{LO}	output leakage current	AOUT disabled	–	–	250	nA
Accuracy						
OS_e	offset error	$T_{amb} = 25\text{ }^\circ\text{C}$	–	–	50	mV
L_e	linearity error		–	–	± 1.5	LSB
G_e	gain error	no resistive load	–	–	1	%
t_{DAC}	settling time	to $\frac{1}{2}$ LSB full scale step	–	–	90	μs
f_{DAC}	conversion rate		–	–	11.1	kHz
SNRR	supply noise rejection ratio	$f = 100\text{ Hz}$; $V_{DDN} = 0.1 \times V_{PP}$	–	40	–	dB

13 A/D CHARACTERISTICS

$V_{DD} = 5.0\text{ V}$; $V_{SS} = 0\text{ V}$; $V_{REF} = 5.0\text{ V}$; $V_{AGND} = 0\text{ V}$; $R_S = 10\text{ k}\Omega$; $T_{amb} = -40\text{ }^\circ\text{C}$ to $+85\text{ }^\circ\text{C}$ unless otherwise specified.

SYMBOL	PARAMETER	CONDITIONS	MIN.	TYP.	MAX.	UNIT
Analog inputs						
V_{IA}	analog input voltage		V_{SS}	–	V_{DD}	V
I_{LIA}	analog input leakage current		–	–	100	nA
C_{IA}	analog input capacitance		–	10	–	pF
C_{ID}	differential input capacitance		–	10	–	pF
V_{IS}	single-ended voltage	measuring range	V_{AGND}	–	V_{REF}	V
V_{ID}	differential voltage	measuring range; $V_{FS} = V_{REF} - V_{AGND}$	$-\frac{V_{FS}}{2}$	–	$+\frac{V_{FS}}{2}$	V
Accuracy						
OS_e	offset error	$T_{amb} = 25\text{ }^\circ\text{C}$	–	–	20	mV
L_e	linearity error		–	–	± 1.5	LSB
G_e	gain error		–	–	1	%
GS_e	small-signal gain error	$\Delta V_i = 16\text{ LSB}$	–	–	5	%
CMRR	common-mode rejection ratio		–	60	–	dB
SNRR	supply noise rejection ratio	$f = 100\text{ Hz}$; $V_{DDN} = 0.1 \times V_{PP}$	–	40	–	dB
t_{ADC}	conversion time		–	–	90	μs
f_{ADC}	sampling/conversion rate		–	–	11.1	kHz

8-bit A/D and D/A converter

PCF8591

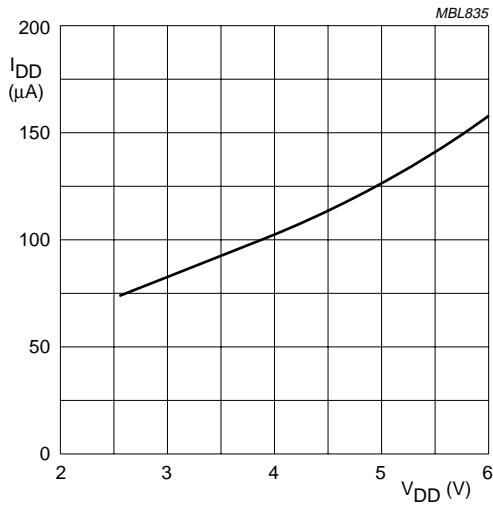

a. Internal oscillator; T_{amb} = +27° C.

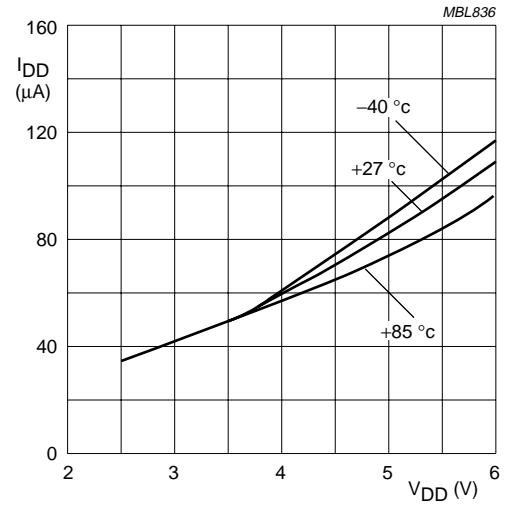

b. External oscillator.

Fig.18 Operating supply current as a function of supply voltage (analog output disabled).

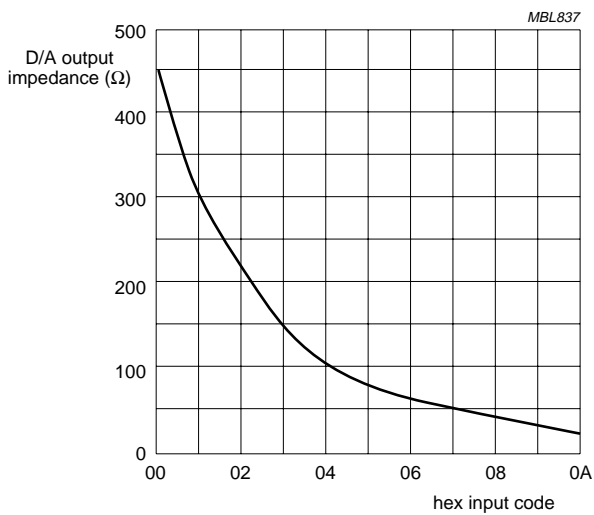

a. Output impedance near negative power rail; T_{amb} = +27 °C.

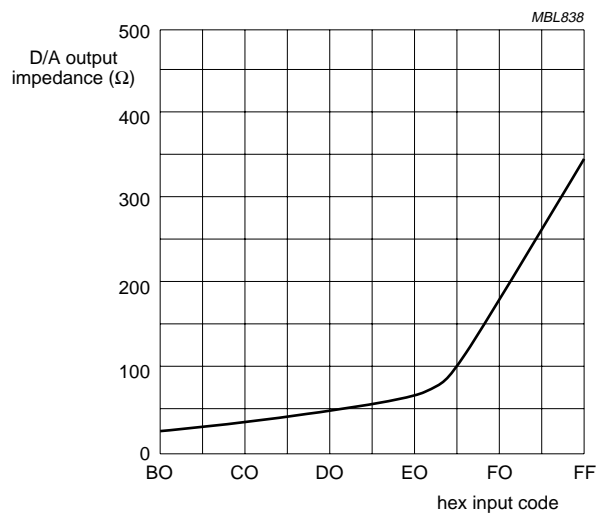

b. Output impedance near positive power rail; T_{amb} = +27 °C.

The x-axis represents the hex input-code equivalent of the output voltage.

Fig.19 Output impedance of analog output buffer (near power rails).

8-bit A/D and D/A converter

PCF8591

14 AC CHARACTERISTICS

All timing values are valid within the operating supply voltage and ambient temperature range and reference to V_{IL} and V_{IH} with an input voltage swing of V_{SS} to V_{DD} .

SYMBOL	PARAMETER	MIN.	TYP.	MAX.	UNIT
I²C-bus timing (see Fig.20; note 1)					
f_{SCL}	SCL clock frequency	–	–	100	kHz
t_{SP}	tolerable spike width on bus	–	–	100	ns
t_{BUF}	bus free time	4.7	–	–	μ s
$t_{SU;STA}$	START condition set-up time	4.7	–	–	μ s
$t_{HD;STA}$	START condition hold time	4.0	–	–	μ s
t_{LOW}	SCL LOW time	4.7	–	–	μ s
t_{HIGH}	SCL HIGH time	4.0	–	–	μ s
t_r	SCL and SDA rise time	–	–	1.0	μ s
t_f	SCL and SDA fall time	–	–	0.3	μ s
$t_{SU;DAT}$	data set-up time	250	–	–	ns
$t_{HD;DAT}$	data hold time	0	–	–	ns
$t_{VD;DAT}$	SCL LOW-to-data out valid	–	–	3.4	μ s
$t_{SU;STO}$	STOP condition set-up time	4.0	–	–	μ s

Note

1. A detailed description of the I²C-bus specification, with applications, is given in brochure “The I²C-bus and how to use it”. This brochure may be ordered using the code 9398 393 40011.

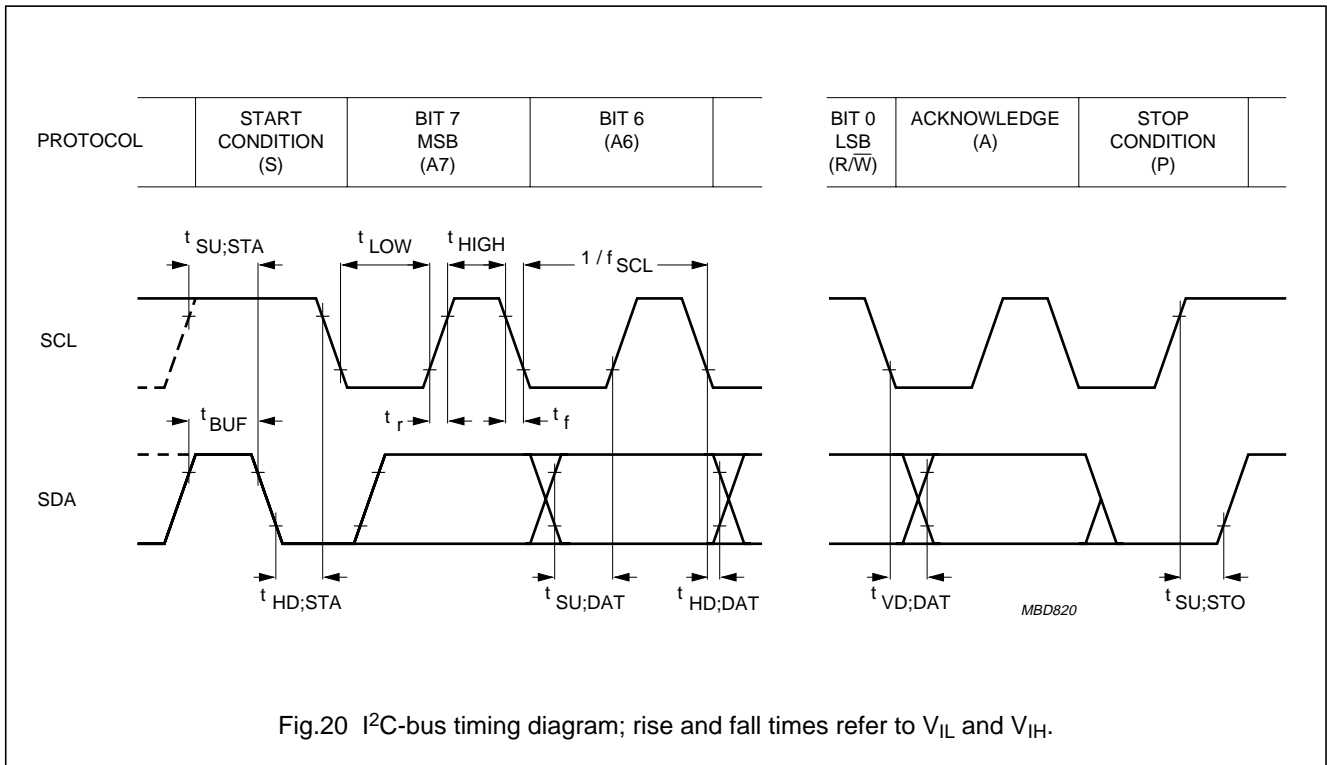

Fig.20 I²C-bus timing diagram; rise and fall times refer to V_{IL} and V_{IH} .

8-bit A/D and D/A converter

PCF8591

15 APPLICATION INFORMATION

Inputs must be connected to V_{SS} or V_{DD} when not in use. Analog inputs may also be connected to AGND or V_{REF} .

In order to prevent excessive ground and supply noise and to minimize cross-talk of the digital to analog signal paths the user has to design the printed-circuit board layout very carefully. Supply lines common to a PCF8591 device and noisy digital circuits and ground loops should be avoided. Decoupling capacitors ($>10 \mu\text{F}$) are recommended for power supply and reference voltage inputs.

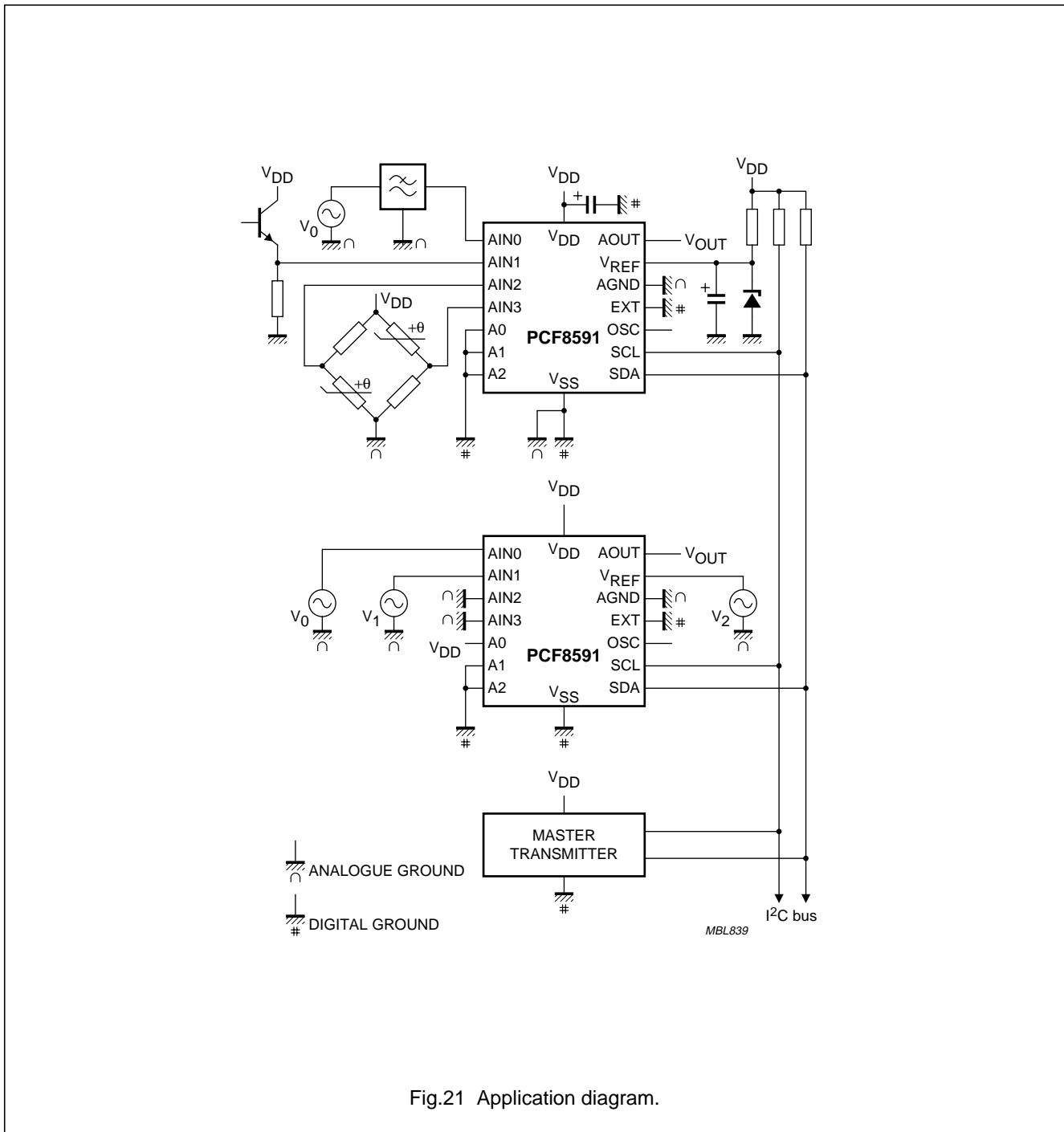

Fig.21 Application diagram.

8-bit A/D and D/A converter

PCF8591

16 PACKAGE OUTLINES

DIP16: plastic dual in-line package; 16 leads (300 mil)

SOT38-4

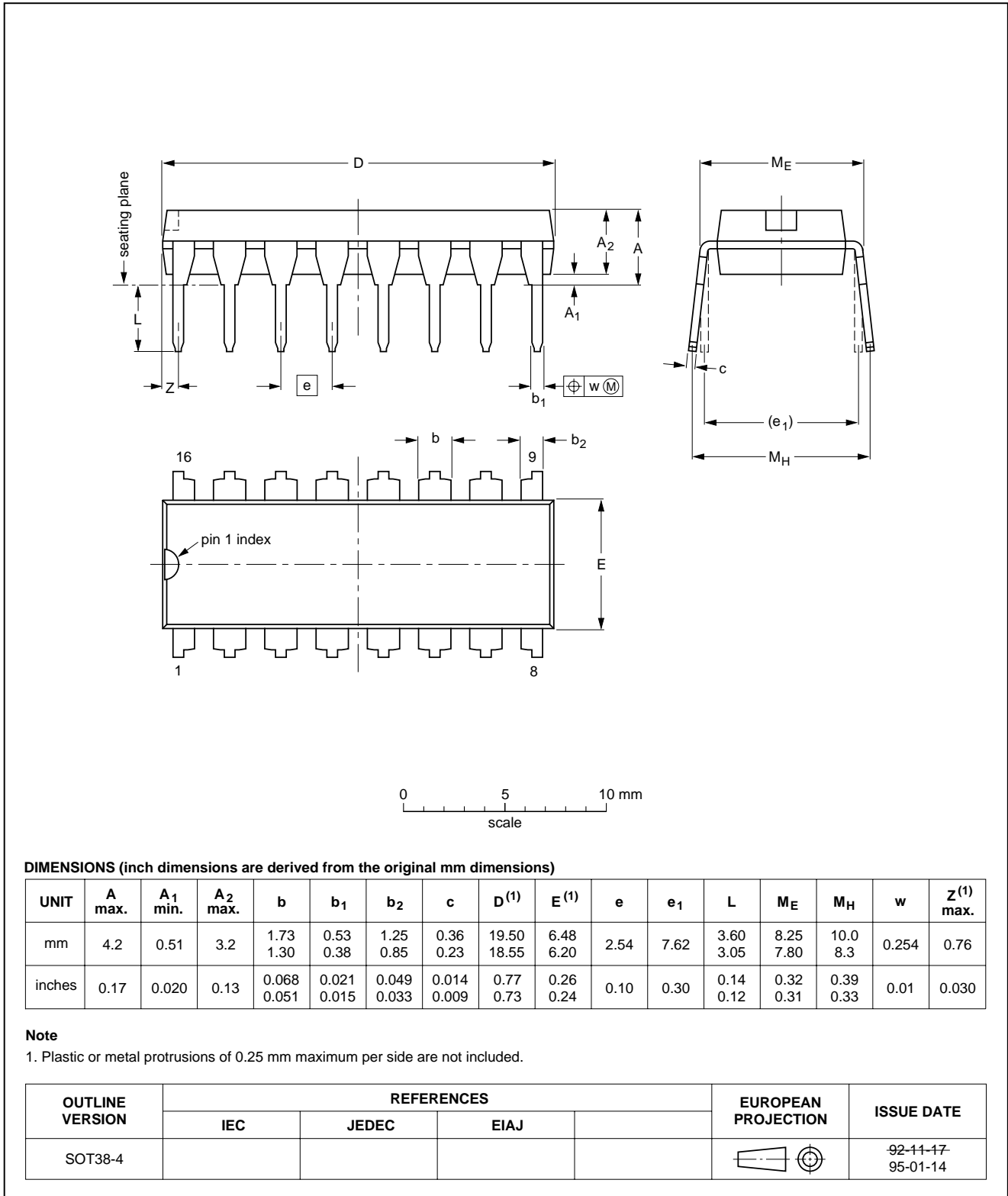

8-bit A/D and D/A converter

PCF8591

SO16: plastic small outline package; 16 leads; body width 7.5 mm

SOT162-1

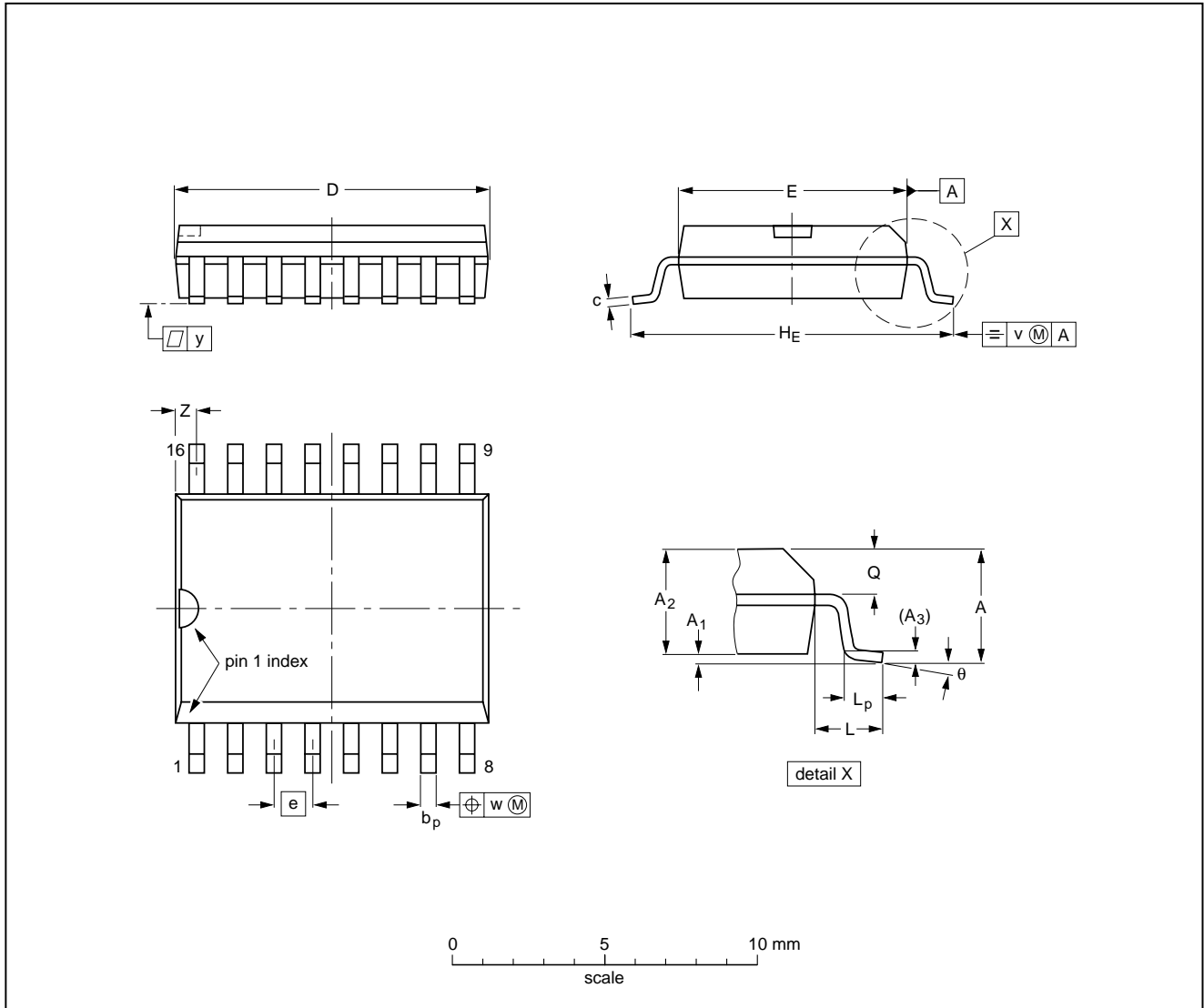

DIMENSIONS (inch dimensions are derived from the original mm dimensions)

UNIT	A max.	A ₁	A ₂	A ₃	b _p	c	D ⁽¹⁾	E ⁽¹⁾	e	H _E	L	L _p	Q	v	w	y	z ⁽¹⁾	θ
mm	2.65	0.30 0.10	2.45 2.25	0.25	0.49 0.36	0.32 0.23	10.5 10.1	7.6 7.4	1.27	10.65 10.00	1.4	1.1 0.4	1.1 1.0	0.25	0.25	0.1	0.9 0.4	8° 0°
inches	0.10	0.012 0.004	0.096 0.089	0.01	0.019 0.014	0.013 0.009	0.41 0.40	0.30 0.29	0.050	0.419 0.394	0.055	0.043 0.016	0.043 0.039	0.01	0.01	0.004	0.035 0.016	

Note

1. Plastic or metal protrusions of 0.15 mm maximum per side are not included.

OUTLINE VERSION	REFERENCES				EUROPEAN PROJECTION	ISSUE DATE
	IEC	JEDEC	EIAJ			
SOT162-1	075E03	MS-013				97-05-22 99-12-27

8-bit A/D and D/A converter

PCF8591

17 SOLDERING**17.1 Introduction to soldering through-hole mount packages**

This text gives a brief insight to wave, dip and manual soldering. A more in-depth account of soldering ICs can be found in our *"Data Handbook IC26; Integrated Circuit Packages"* (document order number 9398 652 90011).

Wave soldering is the preferred method for mounting of through-hole mount IC packages on a printed-circuit board.

17.2 Soldering by dipping or by solder wave

The maximum permissible temperature of the solder is 260 °C; solder at this temperature must not be in contact with the joints for more than 5 seconds.

17.4 Suitability of through-hole mount IC packages for dipping and wave soldering methods

PACKAGE	SOLDERING METHOD	
	DIPPING	WAVE
DBS, DIP, HDIP, SDIP, SIL	suitable	suitable ⁽¹⁾

Note

- For SDIP packages, the longitudinal axis must be parallel to the transport direction of the printed-circuit board.

The total contact time of successive solder waves must not exceed 5 seconds.

The device may be mounted up to the seating plane, but the temperature of the plastic body must not exceed the specified maximum storage temperature ($T_{stg(max)}$). If the printed-circuit board has been pre-heated, forced cooling may be necessary immediately after soldering to keep the temperature within the permissible limit.

17.3 Manual soldering

Apply the soldering iron (24 V or less) to the lead(s) of the package, either below the seating plane or not more than 2 mm above it. If the temperature of the soldering iron bit is less than 300 °C it may remain in contact for up to 10 seconds. If the bit temperature is between 300 and 400 °C, contact may be up to 5 seconds.

8-bit A/D and D/A converter

PCF8591

18 DATA SHEET STATUS

LEVEL	DATA SHEET STATUS ⁽¹⁾	PRODUCT STATUS ⁽²⁾⁽³⁾	DEFINITION
I	Objective data	Development	This data sheet contains data from the objective specification for product development. Philips Semiconductors reserves the right to change the specification in any manner without notice.
II	Preliminary data	Qualification	This data sheet contains data from the preliminary specification. Supplementary data will be published at a later date. Philips Semiconductors reserves the right to change the specification without notice, in order to improve the design and supply the best possible product.
III	Product data	Production	This data sheet contains data from the product specification. Philips Semiconductors reserves the right to make changes at any time in order to improve the design, manufacturing and supply. Relevant changes will be communicated via a Customer Product/Process Change Notification (CPCN).

Notes

1. Please consult the most recently issued data sheet before initiating or completing a design.
2. The product status of the device(s) described in this data sheet may have changed since this data sheet was published. The latest information is available on the Internet at URL <http://www.semiconductors.philips.com>.
3. For data sheets describing multiple type numbers, the highest-level product status determines the data sheet status.

19 DEFINITIONS

Short-form specification — The data in a short-form specification is extracted from a full data sheet with the same type number and title. For detailed information see the relevant data sheet or data handbook.

Limiting values definition — Limiting values given are in accordance with the Absolute Maximum Rating System (IEC 60134). Stress above one or more of the limiting values may cause permanent damage to the device. These are stress ratings only and operation of the device at these or at any other conditions above those given in the Characteristics sections of the specification is not implied. Exposure to limiting values for extended periods may affect device reliability.

Application information — Applications that are described herein for any of these products are for illustrative purposes only. Philips Semiconductors make no representation or warranty that such applications will be suitable for the specified use without further testing or modification.

20 DISCLAIMERS

Life support applications — These products are not designed for use in life support appliances, devices, or systems where malfunction of these products can reasonably be expected to result in personal injury. Philips Semiconductors customers using or selling these products for use in such applications do so at their own risk and agree to fully indemnify Philips Semiconductors for any damages resulting from such application.

Right to make changes — Philips Semiconductors reserves the right to make changes in the products - including circuits, standard cells, and/or software - described or contained herein in order to improve design and/or performance. When the product is in full production (status 'Production'), relevant changes will be communicated via a Customer Product/Process Change Notification (CPCN). Philips Semiconductors assumes no responsibility or liability for the use of any of these products, conveys no licence or title under any patent, copyright, or mask work right to these products, and makes no representations or warranties that these products are free from patent, copyright, or mask work right infringement, unless otherwise specified.

8-bit A/D and D/A converter**PCF8591**

21 PURCHASE OF PHILIPS I²C COMPONENTS

Purchase of Philips I²C components conveys a license under the Philips' I²C patent to use the components in the I²C system provided the system conforms to the I²C specification defined by Philips. This specification can be ordered using the code 9398 393 40011.

8-bit A/D and D/A converter

PCF8591

NOTES

8-bit A/D and D/A converter

PCF8591

NOTES

Philips Semiconductors – a worldwide company

Contact information

For additional information please visit <http://www.semiconductors.philips.com>. Fax: +31 40 27 24825

For sales offices addresses send e-mail to: sales.addresses@www.semiconductors.philips.com.

© Koninklijke Philips Electronics N.V. 2003

SCA75

All rights are reserved. Reproduction in whole or in part is prohibited without the prior written consent of the copyright owner.

The information presented in this document does not form part of any quotation or contract, is believed to be accurate and reliable and may be changed without notice. No liability will be accepted by the publisher for any consequence of its use. Publication thereof does not convey nor imply any license under patent- or other industrial or intellectual property rights.

Printed in The Netherlands

403512/06/pp28

Date of release: 2003 Jan 27

Document order number: 9397 750 10464

Let's make things better.

**Philips
Semiconductors**



PHILIPS