



HESTORE.HU

elektronikai alkatrész áruház

EN: This Datasheet is presented by the manufacturer.

Please visit our website for pricing and availability at www.hestore.hu.

Features

- High Voltage Types (20V Rating)
- Quad NOR R/S Latch- CD4043BMS
- Quad NAND R/S Latch - CD4044BMS
- 3 State Outputs with Common Output ENABLE
- Separate SET and RESET Inputs for Each Latch
- NOR and NAND Configuration
- 5V, 10V and 15V Parametric Ratings
- Standardized Symmetrical Output Characteristics
- 100% Tested for Quiescent Current at 20V
- Maximum Input Current of 1 μ A at 18V Over Full Package-Temperature Range;
 - 100nA at 18V and 25 $^{\circ}$ C
- Noise Margin (Over Full Package Temperature Range):
 - 1V at VDD = 5V
 - 2V at VDD = 10V
 - 2.5V at VDD = 15V
- Meets All Requirements of JEDEC Tentative Standard No. 13B, "Standard Specifications for Description of 'B' Series CMOS Devices"

Applications

- Holding Register in Multi-Register System
- Four Bits of Independent Storage with Output ENABLE
- Strobed Register
- General Digital Logic
- CD4043BMS for Positive Logic Systems
- CD4044BMS for Negative Logic Systems

Description

CD4043BMS types are quad cross-coupled 3-state CMOS NOR latches and the CD4044BMS types are quad cross-coupled 3-state CMOS NAND latches. Each latch has a separate Q output and individual SET and RESET inputs. The Q outputs are controlled by a common ENABLE input. A logic "1" or high on the ENABLE input connects the latch states to the Q outputs. A logic "0" or low on the ENABLE input disconnects the latch states from the Q outputs, results in an open circuit feature allows common bussing of the outputs.

The CD4043BMS and CD4044BMS are supplied in these 16-lead outline packages:

Braze Seal DIP	*H4T	†H4T
Frit Seal DIP	*H1C	†H1E
Ceramic Flatpack	*H3X	†H6W
*CD4043B Only	†CD4044B Only	

Pinout

CD4043BMS
TOP VIEW

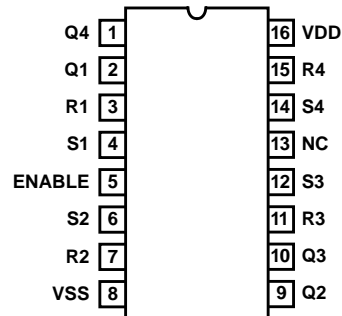

NC = NO CONNECTION

CD4044BMS
TOP VIEW

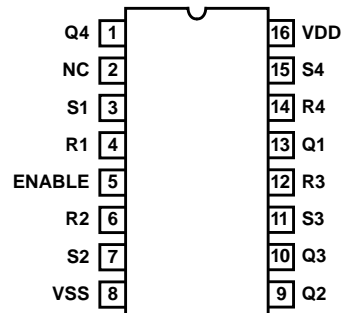

NC = NO CONNECTION

Specifications CD4043BMS, CD4044BMS

Absolute Maximum Ratings

DC Supply Voltage Range, (VDD)	-0.5V to +20V (Voltage Referenced to VSS Terminals)
Input Voltage Range, All Inputs	-0.5V to VDD +0.5V
DC Input Current, Any One Input	±10mA
Operating Temperature Range	-55°C to +125°C Package Types D, F, K, H
Storage Temperature Range (TSTG)	-65°C to +150°C
Lead Temperature (During Soldering)	+265°C At Distance 1/16 ± 1/32 Inch (1.59mm ± 0.79mm) from case for 10s Maximum

Reliability Information

Thermal Resistance	θ_{ja}	θ_{jc}
Ceramic DIP and FRIT Package	80°C/W	20°C/W
Flatpack Package	70°C/W	20°C/W
Maximum Package Power Dissipation (PD) at +125°C		
For TA = -55°C to +100°C (Package Type D, F, K)	500mW	
For TA = +100°C to +125°C (Package Type D, F, K)	Derate Linearity at 12mW/°C to 200mW	
Device Dissipation per Output Transistor	100mW	
For TA = Full Package Temperature Range (All Package Types)		
Junction Temperature	+175°C	

TABLE 1. DC ELECTRICAL PERFORMANCE CHARACTERISTICS

PARAMETER	SYMBOL	CONDITIONS (NOTE 1)	GROUP A SUBGROUPS	TEMPERATURE	LIMITS		UNITS	
					MIN	MAX		
Supply Current	IDD	VDD = 20V, VIN = VDD or GND	1	+25°C	-	2	μA	
			2	+125°C	-	200	μA	
		VDD = 18V, VIN = VDD or GND	3	-55°C	-	2	μA	
Input Leakage Current	IIL	VIN = VDD or GND	VDD = 20	1	+25°C	-100	-	nA
				2	+125°C	-1000	-	nA
			VDD = 18V	3	-55°C	-100	-	nA
Input Leakage Current	IIH	VIN = VDD or GND	VDD = 20	1	+25°C	-	100	nA
				2	+125°C	-	1000	nA
			VDD = 18V	3	-55°C	-	100	nA
Output Voltage	VOL15	VDD = 15V, No Load	1, 2, 3	+25°C, +125°C, -55°C	-	50	mV	
Output Voltage	VOH15	VDD = 15V, No Load (Note 3)	1, 2, 3	+25°C, +125°C, -55°C	14.95	-	V	
Output Current (Sink)	IOL5	VDD = 5V, VOUT = 0.4V	1	+25°C	0.53	-	mA	
Output Current (Sink)	IOL10	VDD = 10V, VOUT = 0.5V	1	+25°C	1.4	-	mA	
Output Current (Sink)	IOL15	VDD = 15V, VOUT = 1.5V	1	+25°C	3.5	-	mA	
Output Current (Source)	IOH5A	VDD = 5V, VOUT = 4.6V	1	+25°C	-	-0.53	mA	
Output Current (Source)	IOH5B	VDD = 5V, VOUT = 2.5V	1	+25°C	-	-1.8	mA	
Output Current (Source)	IOH10	VDD = 10V, VOUT = 9.5V	1	+25°C	-	-1.4	mA	
Output Current (Source)	IOH15	VDD = 15V, VOUT = 13.5V	1	+25°C	-	-3.5	mA	
N Threshold Voltage	VNTH	VDD = 10V, ISS = -10μA	1	+25°C	-2.8	-0.7	V	
P Threshold Voltage	VPTH	VSS = 0V, IDD = 10μA	1	+25°C	0.7	2.8	V	
Functional	F	VDD = 2.8V, VIN = VDD or GND	7	+25°C	VOH > VDD/2	VOL < VDD/2	V	
		VDD = 20V, VIN = VDD or GND	7	+25°C				
		VDD = 18V, VIN = VDD or GND	8A	+125°C				
		VDD = 3V, VIN = VDD or GND	8B	-55°C				
Input Voltage Low (Note 2)	VIL	VDD = 5V, VOH > 4.5V, VOL < 0.5V	1, 2, 3	+25°C, +125°C, -55°C	-	1.5	V	
Input Voltage High (Note 2)	VIH	VDD = 5V, VOH > 4.5V, VOL < 0.5V	1, 2, 3	+25°C, +125°C, -55°C	3.5	-	V	
Input Voltage Low (Note 2)	VIL	VDD = 15V, VOH > 13.5V, VOL < 1.5V	1, 2, 3	+25°C, +125°C, -55°C	-	4	V	
Input Voltage High (Note 2)	VIH	VDD = 15V, VOH > 13.5V, VOL < 1.5V	1, 2, 3	+25°C, +125°C, -55°C	11	-	V	
Tri-State Output Leakage	IOZL	VIN = VDD or GND VOUT = 0V	VDD = 20V	1	+25°C	-0.4	-	μA
				2	+125°C	-12	-	μA
			VDD = 18V	3	-55°C	-0.4	-	μA
Tri-State Output Leakage	IOZH	VIN = VDD or GND VOUT = VDD	VDD = 20V	1	+25°C	-	0.4	μA
				2	+125°C	-	12	μA
			VDD = 18V	3	-55°C	-	0.4	μA

NOTES: 1. All voltages referenced to device GND, 100% testing being implemented. 2. Go/No Go test with limits applied to inputs. 3. For accuracy, voltage is measured differentially to VDD. Limit is 0.050V max.

Specifications CD4043BMS, CD4044BMS

TABLE 2. AC ELECTRICAL PERFORMANCE CHARACTERISTICS

PARAMETER	SYMBOL	CONDITIONS	GROUP A SUBGROUPS	TEMPERATURE	LIMITS		UNITS
					MIN	MAX	
Propagation Delay Set or Reset to Q	TPHL TPLH	VDD = 5V, VIN = VDD or GND (Notes 1, 2)	9	+25°C	-	300	ns
			10, 11	+125°C, -55°C	-	405	ns
Propagation Delay 3 - State Enable to Q	TPHZ TPZH	VDD = 5V, VIN = VDD or GND (Notes 2, 3)	9	+25°C	-	230	ns
			10, 11	+125°C, -55°C	-	311	ns
Propagation Delay 3 - State Enable to Q	TPLZ TPZL	VDD = 5V, VIN = VDD or GND (Notes 2, 3)	9	+25°C	-	180	ns
			10, 11	+125°C, -55°C	-	243	ns
Transition Time	TTHL TTLH	VDD = 5V, VIN = VDD or GND (Notes 1, 2)	9	+25°C	-	200	ns
			10, 11	+125°C, -55°C	-	270	ns

NOTES:

1. CL = 50pF, RL = 200K, Input TR, TF < 20ns.
2. -55°C and +125°C limits guaranteed, 100% testing being implemented.
1. CL = 50pF, RL = 1K, Input TR, TF < 20ns.

TABLE 3. ELECTRICAL PERFORMANCE CHARACTERISTICS

PARAMETER	SYMBOL	CONDITIONS	NOTES	TEMPERATURE	LIMITS		UNITS
					MIN	MAX	
Supply Current	IDD	VDD = 5V, VIN = VDD or GND	1, 2	-55°C, +25°C	-	1	μA
				+125°C	-	30	μA
		VDD = 10V, VIN = VDD or GND	1, 2	-55°C, +25°C	-	2	μA
				+125°C	-	60	μA
		VDD = 15V, VIN = VDD or GND	1, 2	-55°C, +25°C	-	2	μA
+125°C	-			120	μA		
Output Voltage	VOL	VDD = 5V, No Load	1, 2	+25°C, +125°C, -55°C	-	50	mV
Output Voltage	VOL	VDD = 10V, No Load	1, 2	+25°C, +125°C, -55°C	-	50	mV
Output Voltage	VOH	VDD = 5V, No Load	1, 2	+25°C, +125°C, -55°C	4.95	-	V
Output Voltage	VOH	VDD = 10V, No Load	1, 2	+25°C, +125°C, -55°C	9.95	-	V
Output Current (Sink)	IOL5	VDD = 5V, VOUT = 0.4V	1, 2	+125°C	0.36	-	mA
				-55°C	0.64	-	mA
Output Current (Sink)	IOL10	VDD = 10V, VOUT = 0.5V	1, 2	+125°C	0.9	-	mA
				-55°C	1.6	-	mA
Output Current (Sink)	IOL15	VDD = 15V, VOUT = 1.5V	1, 2	+125°C	2.4	-	mA
				-55°C	4.2	-	mA
Output Current (Source)	IOH5A	VDD = 5V, VOUT = 4.6V	1, 2	+125°C	-	-0.36	mA
				-55°C	-	-0.64	mA
Output Current (Source)	IOH5B	VDD = 5V, VOUT = 2.5V	1, 2	+125°C	-	-1.15	mA
				-55°C	-	-2.0	mA
Output Current (Source)	IOH10	VDD = 10V, VOUT = 9.5V	1, 2	+125°C	-	-0.9	mA
				-55°C	-	-1.6	mA
Output Current (Source)	IOH15	VDD = 15V, VOUT = 13.5V	1, 2	+125°C	-	-2.4	mA
				-55°C	-	-4.2	mA

Specifications CD4043BMS, CD4044BMS

TABLE 3. ELECTRICAL PERFORMANCE CHARACTERISTICS (Continued)

PARAMETER	SYMBOL	CONDITIONS	NOTES	TEMPERATURE	LIMITS		UNITS
					MIN	MAX	
Input Voltage Low	VIL	VDD = 10V, VOH > 9V, VOL < 1V	1, 2	+25°C, +125°C, -55°C	-	3	V
Input Voltage High	VIH	VDD = 10V, VOH > 9V, VOL < 1V	1, 2	+25°C, +125°C, -55°C	7	-	V
Propagation Delay Set or Reset to Q	TPLH TPHL	VDD = 10V	1, 2, 3	+25°C	-	140	ns
		VDD = 15V	1, 2, 3	+25°C	-	100	ns
Propagation Delay 3 State Enable to Q	TPHZ TPZH	VDD = 10V	1, 2, 4	+25°C	-	110	ns
		VDD = 15V	1, 2, 4	+25°C	-	80	ns
Propagation Delay 3 State Enable to Q	TPLZ TPZL	VDD = 10V	1, 2, 4	+25°C	-	100	ns
		VDD = 15V	1, 2, 4	+25°C	-	70	ns
Transition Time	TTHL TTLH	VDD = 10V	1, 2, 3	+25°C	-	100	ns
		VDD = 15V	1, 2, 3	+25°C	-	80	ns
Minimum Set or Reset Pulse Width	TW	VDD = 5V	1, 2, 3	+25°C	-	160	ns
		VDD = 10V	1, 2, 3	+25°C	-	80	ns
		VDD = 15V	1, 2, 3	+25°C	-	40	ns
Input Capacitance	CIN	Any Input	1, 2	+25°C	-	7.5	pF

NOTES:

1. All voltages referenced to device GND.
2. The parameters listed on Table 3 are controlled via design or process and are not directly tested. These parameters are characterized on initial design release and upon design changes which would affect these characteristics.
3. CL = 50pF, RL = 200K, Input TR, TF < 20ns.
4. CL = 50pF, RL = 1K, Input TR, TF < 20ns.

TABLE 4. POST IRRADIATION ELECTRICAL PERFORMANCE CHARACTERISTICS

PARAMETER	SYMBOL	CONDITIONS	NOTES	TEMPERATURE	LIMITS		UNITS
					MIN	MAX	
Supply Current	IDD	VDD = 20V, VIN = VDD or GND	1, 4	+25°C	-	7.5	μA
N Threshold Voltage	VNTH	VDD = 10V, ISS = -10μA	1, 4	+25°C	-2.8	-0.2	V
N Threshold Voltage Delta	ΔVTN	VDD = 10V, ISS = -10μA	1, 4	+25°C	-	±1	V
P Threshold Voltage	VTP	VSS = 0V, IDD = 10μA	1, 4	+25°C	0.2	2.8	V
P Threshold Voltage Delta	ΔVTP	VSS = 0V, IDD = 10μA	1, 4	+25°C	-	±1	V
Functional	F	VDD = 18V, VIN = VDD or GND	1	+25°C	VOH > VDD/2	VOL < VDD/2	V
		VDD = 3V, VIN = VDD or GND					
Propagation Delay Time	TPHL TPLH	VDD = 5V	1, 2, 3, 4	+25°C	-	1.35 x +25°C Limit	ns

- NOTES: 1. All voltages referenced to device GND. 2. CL = 50pF, RL = 200K, Input TR, TF < 20ns. 3. See Table 2 for +25°C limit. 4. Read and Record

TABLE 5. BURN-IN AND LIFE TEST DELTA PARAMETERS +25°C

PARAMETER	SYMBOL	DELTA LIMIT
Supply Current - MSI-1	IDD	± 0.2μA
Output Current (Sink)	IOL5	± 20% x Pre-Test Reading
Output Current (Source)	IOH5A	± 20% x Pre-Test Reading

Specifications CD4043BMS, CD4044BMS

TABLE 6. APPLICABLE SUBGROUPS

CONFORMANCE GROUP		MIL-STD-883 METHOD	GROUP A SUBGROUPS	READ AND RECORD
Initial Test (Pre Burn-In)		100% 5004	1, 7, 9	IDD, IOL5, IOH5A
Interim Test 1 (Post Burn-In)		100% 5004	1, 7, 9	IDD, IOL5, IOH5A
Interim Test 2 (Post Burn-In)		100% 5004	1, 7, 9	IDD, IOL5, IOH5A
PDA (Note 1)		100% 5004	1, 7, 9, Deltas	
Interim Test 3 (Post Burn-In)		100% 5004	1, 7, 9	IDD, IOL5, IOH5A
PDA (Note 1)		100% 5004	1, 7, 9, Deltas	
Final Test		100% 5004	2, 3, 8A, 8B, 10, 11	
Group A		Sample 5005	1, 2, 3, 7, 8A, 8B, 9, 10, 11	
Group B	Subgroup B-5	Sample 5005	1, 2, 3, 7, 8A, 8B, 9, 10, 11, Deltas	Subgroups 1, 2, 3, 9, 10, 11
	Subgroup B-6	Sample 5005	1, 7, 9	
Group D		Sample 5005	1, 2, 3, 8A, 8B, 9	Subgroups 1, 2 3

NOTE: 1. 5% Parametric, 3% Functional; Cumulative for Static 1 and 2.

TABLE 7. TOTAL DOSE IRRADIATION

CONFORMANCE GROUPS	MIL-STD-883 METHOD	TEST		READ AND RECORD	
		PRE-IRRAD	POST-IRRAD	PRE-IRRAD	POST-IRRAD
Group E Subgroup 2	5005	1, 7, 9	Table 4	1, 9	Table 4

TABLE 8. BURN-IN AND IRRADIATION TEST CONNECTIONS

FUNCTION	OPEN	GROUND	VDD	9V ± 0.5V	OSCILLATOR	
					50kHz	25kHz
PART NUMBER CD4043BMS						
Static Burn-In 1 Note 1	1, 2, 9, 10, 13	3 - 8, 11, 12, 14, 15	16			
Static Burn-In 2 Note 1	1, 2, 9, 10, 13	8	3 - 7, 11, 12, 14 - 16			
Dynamic Burn-In Note 1	13	8	5, 16	1, 2, 9, 12	4, 6, 12, 14	3, 7, 11, 15
Irradiation Note 2	1, 2, 9, 10, 13	8	3 - 7, 11, 12, 14 - 16			
PART NUMBER CD4044BMS						
Static Burn-In 1 Note 1	1, 2, 9, 10, 13	3 - 8, 11, 12, 14, 15	16			
Static Burn-In 2 Note 1	1, 2, 9, 10, 13	8	3 - 7, 11, 12, 14 - 16			
Dynamic Burn-In Note 1	2	8	5, 16	1, 9, 10, 13	4, 6, 12, 14	3, 7, 11, 15
Irradiation Note 2	1, 2, 9, 10, 13	8	3 - 7, 11, 12, 14 - 16			

NOTE:

- Each pin except VDD and GND will have a series resistor of $10K \pm 5\%$, $VDD = 18V \pm 0.5V$
- Each pin except VDD and GND will have a series resistor of $47K \pm 5\%$; Group E, Subgroup 2, sample size is 4 dice/wafer, 0 failures, $VDD = 10V \pm 0.5V$

Specifications CD4043BMS, CD4044BMS

Functional Diagram

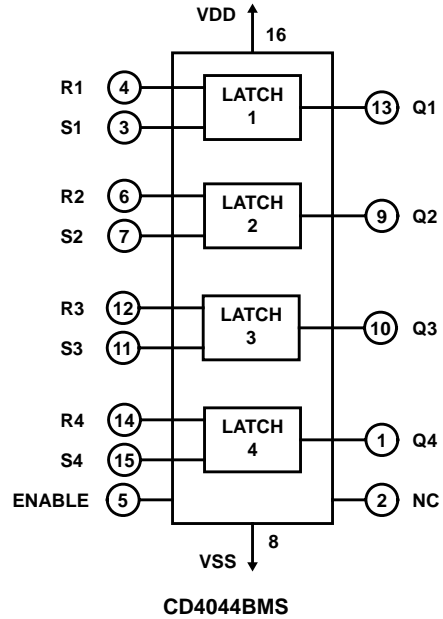
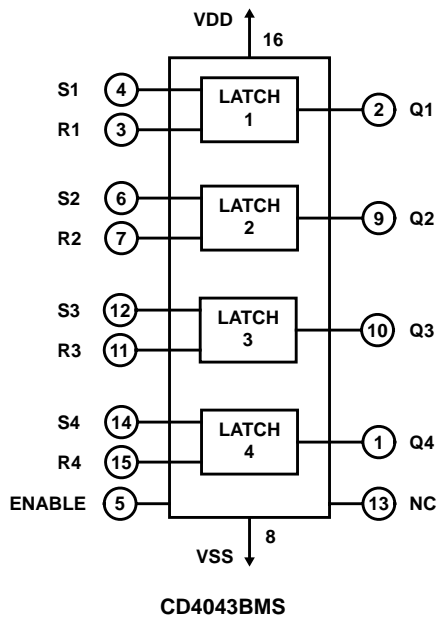

Logic Diagram

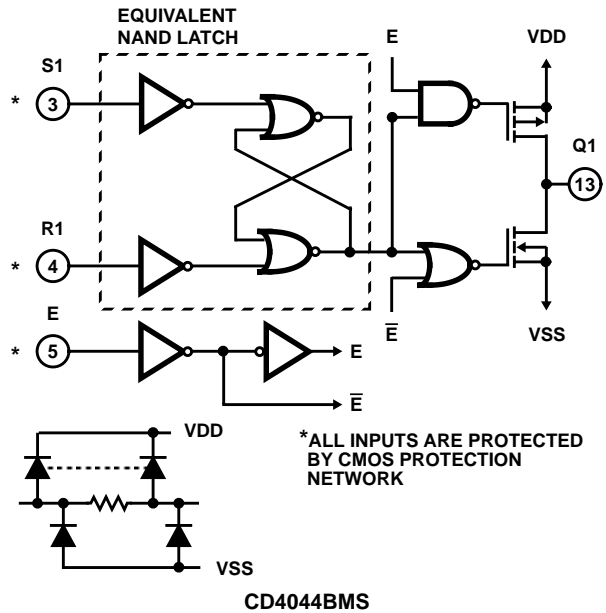
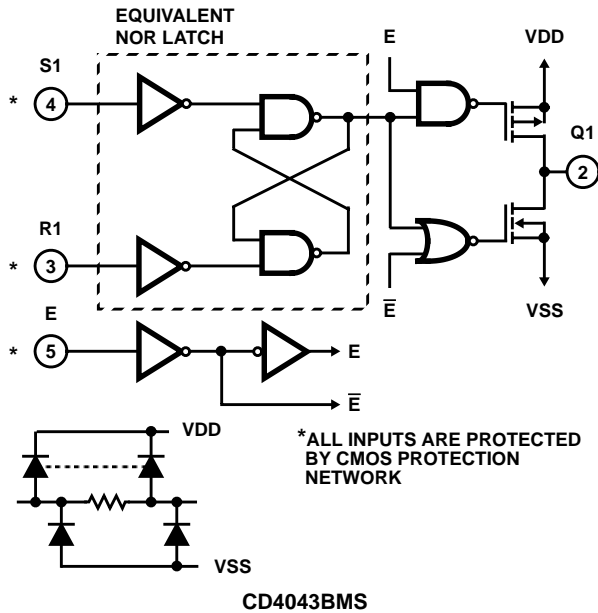

TRUTH TABLE

CD4043BMS

S	R	E	Q
X	X	O	OC*
O	O	1	NC**
1	O	1	1
O	1	1	O
1	1	1	Δ

* Open Circuit

** No Change

Δ Dominated by S = 1 input

CD4044BMS

S	R	E	Q
X	X	O	OC*
1	1	1	NC**
O	1	1	1
1	O	1	O
O	O	1	ΔΔ

* Open Circuit

** No Change

ΔΔ Dominated by R = O input

Typical Performance Characteristics

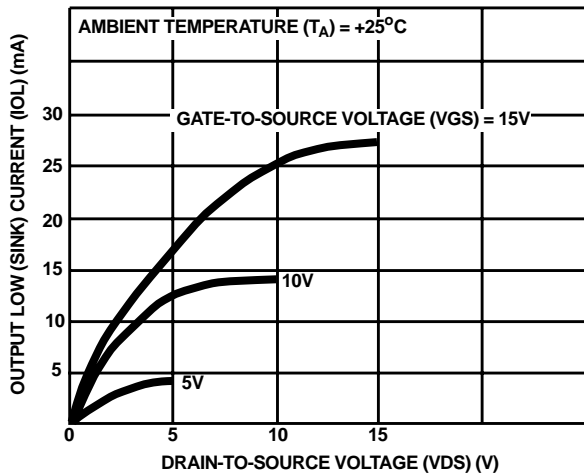

FIGURE 1. TYPICAL OUTPUT LOW (SINK) CURRENT CHARACTERISTICS

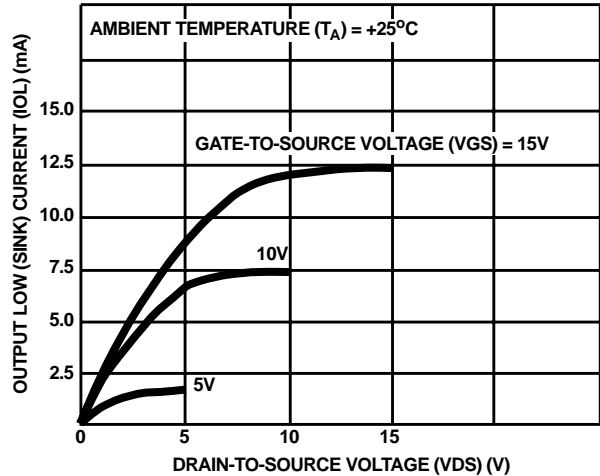

FIGURE 2. MINIMUM OUTPUT LOW (SINK) CURRENT CHARACTERISTICS

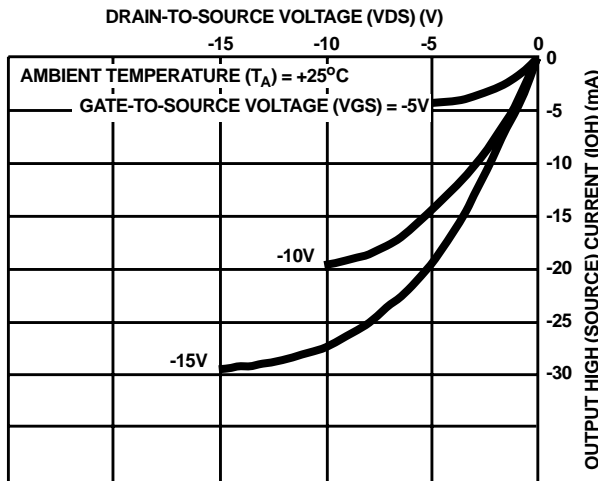

FIGURE 3. TYPICAL OUTPUT HIGH (SOURCE) CURRENT CHARACTERISTICS

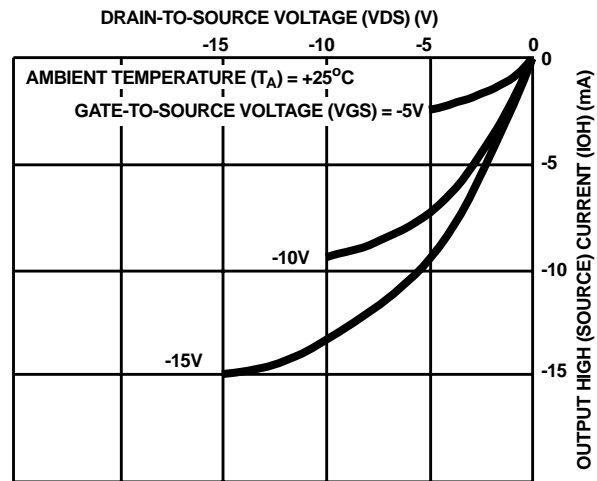

FIGURE 4. MINIMUM OUTPUT HIGH (SOURCE) CURRENT CHARACTERISTICS

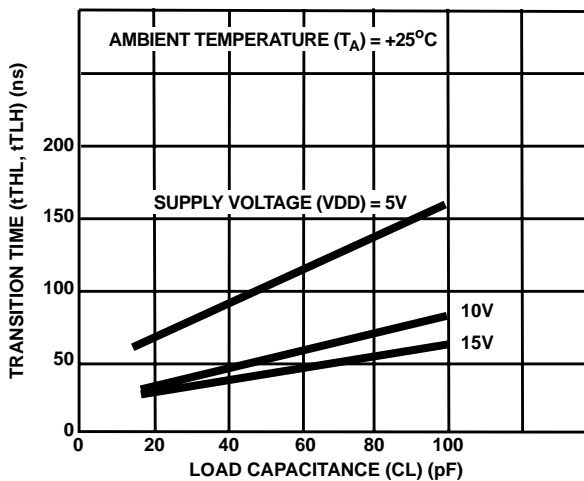

FIGURE 5. TYPICAL TRANSITION TIME AS A FUNCTION OF LOAD CAPACITANCE

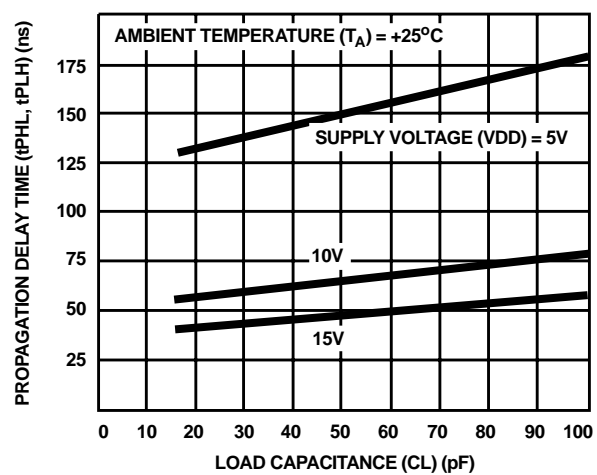

FIGURE 6. TYPICAL PROPAGATION DELAY TIME vs LOAD CAPACITANCE - SET, RESET, to Q, \bar{Q}

Typical Performance Characteristics (Continued)

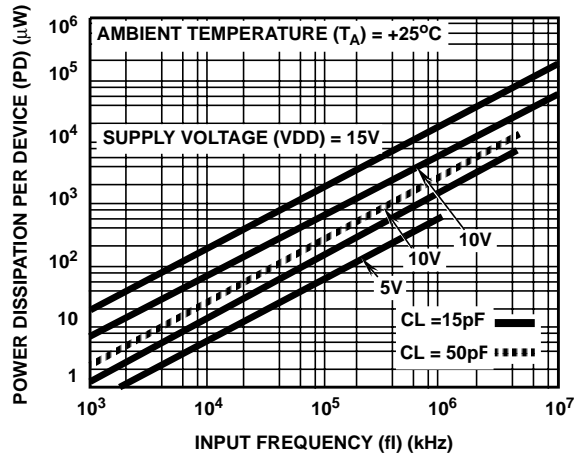

FIGURE 7. TYPICAL POWER DISSIPATION vs FREQUENCY

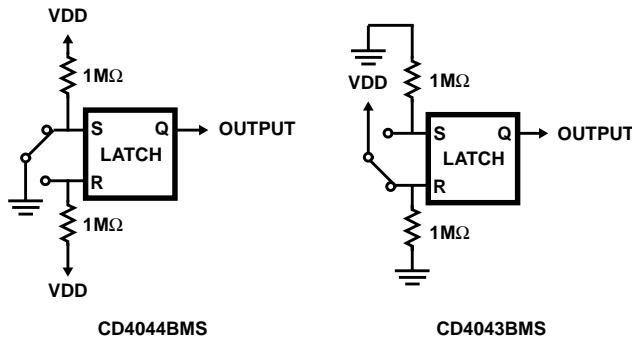

FIGURE 8. SWITCH BOUNCE ELIMINATOR

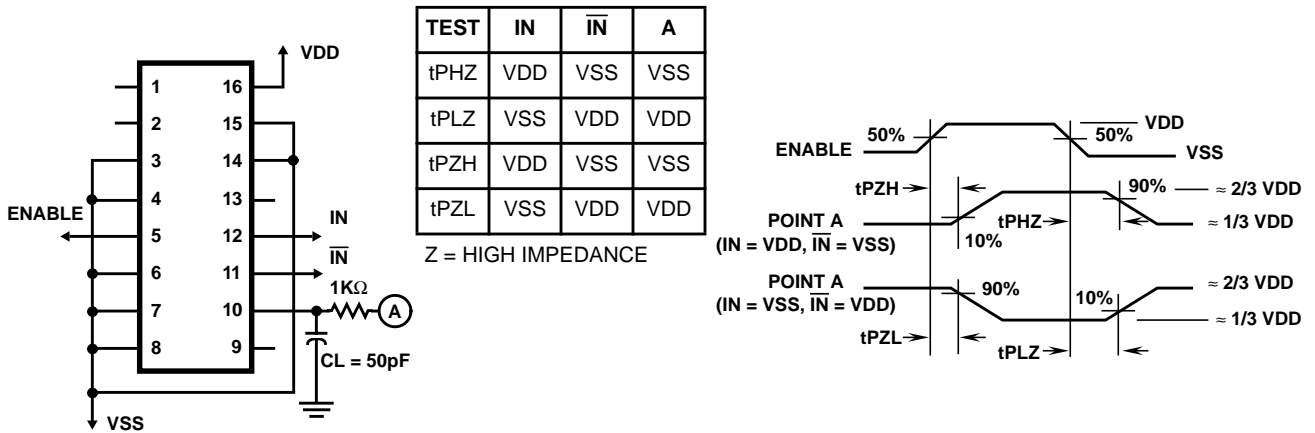

FIGURE 9. ENABLE PROPAGATION DELAY TIME TEST CIRCUIT AND WAVEFORM

CD4043BMS

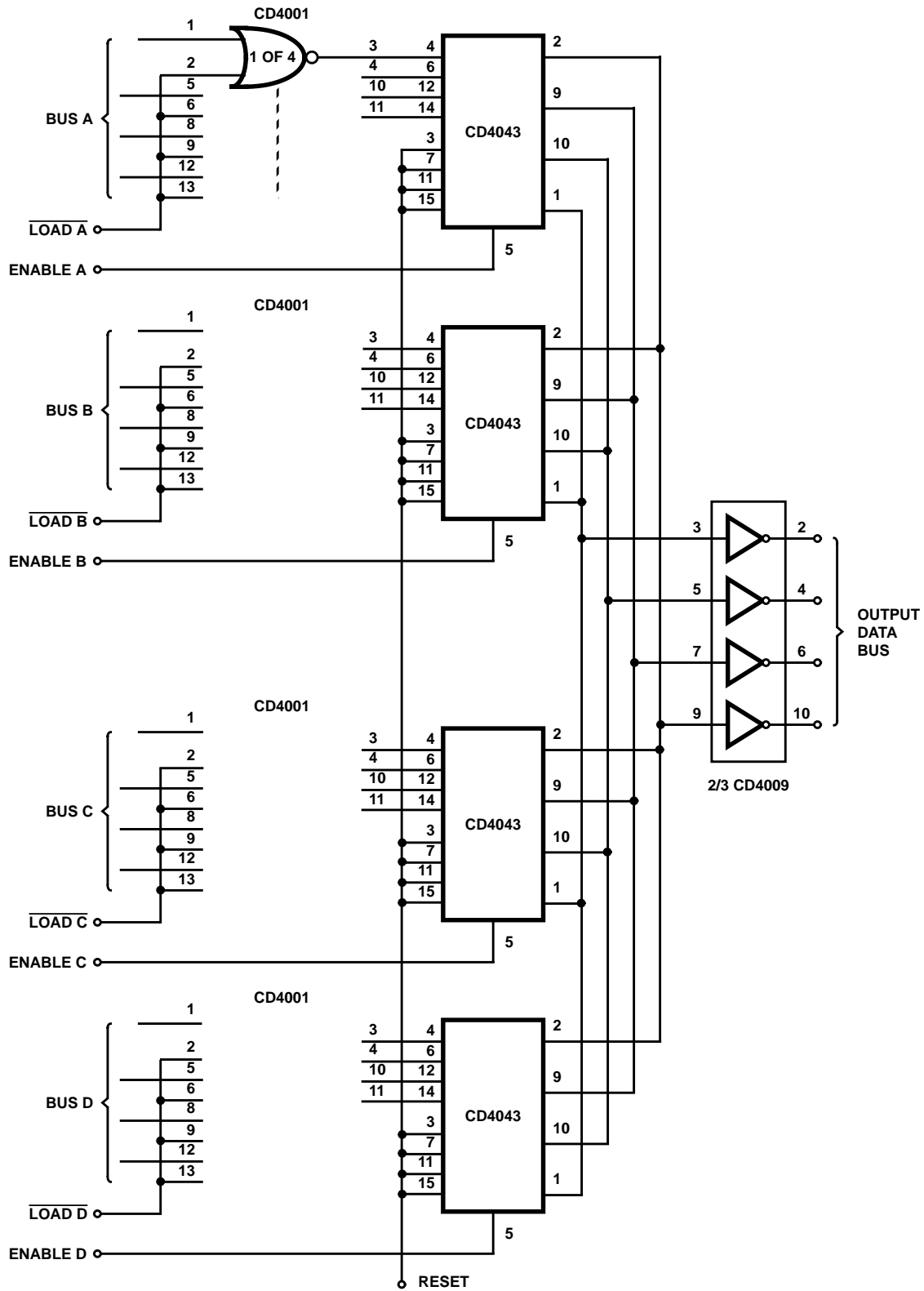
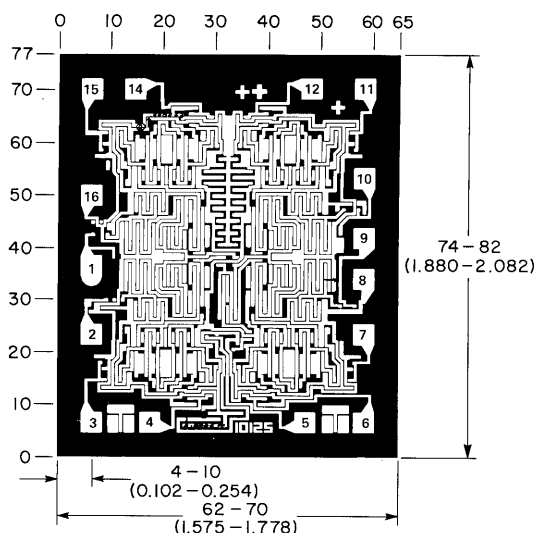

FIGURE 10. MULTIPLE BUS STORAGE

CD4043BMS

Chip Dimensions and Pad Layouts



CD4043BMSH

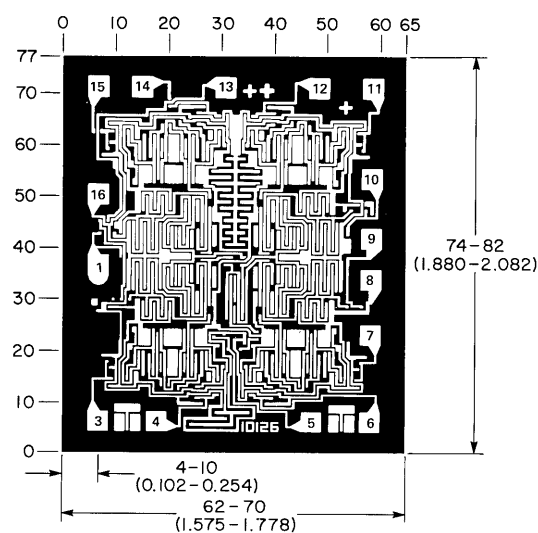

CD4044BMSH

Dimensions in parentheses are in millimeters and are derived from the basic inch dimensions as indicated. Grid graduations are in mils (10^{-3} inch)

METALLIZATION: Thickness: $11\text{k}\text{\AA} - 14\text{k}\text{\AA}$, AL.

PASSIVATION: $10.4\text{k}\text{\AA} - 15.6\text{k}\text{\AA}$, Silane

BOND PADS: 0.004 inches X 0.004 inches MIN

DIE THICKNESS: 0.0198 inches - 0.0218 inches

All Intersil semiconductor products are manufactured, assembled and tested under **ISO9000** quality systems certification.

Intersil products are sold by description only. Intersil Corporation reserves the right to make changes in circuit design and/or specifications at any time without notice. Accordingly, the reader is cautioned to verify that data sheets are current before placing orders. Information furnished by Intersil is believed to be accurate and reliable. However, no responsibility is assumed by Intersil or its subsidiaries for its use; nor for any infringements of patents or other rights of third parties which may result from its use. No license is granted by implication or otherwise under any patent or patent rights of Intersil or its subsidiaries.

For information regarding Intersil Corporation and its products, see web site <http://www.intersil.com>

Sales Office Headquarters

NORTH AMERICA

Intersil Corporation
P. O. Box 883, Mail Stop 53-204
Melbourne, FL 32902
TEL: (321) 724-7000
FAX: (321) 724-7240

EUROPE

Intersil SA
Mercure Center
100, Rue de la Fusee
1130 Brussels, Belgium
TEL: (32) 2.724.2111
FAX: (32) 2.724.22.05

ASIA

Intersil (Taiwan) Ltd.
Taiwan Limited
7F-6, No. 101 Fu Hsing North Road
Taipei, Taiwan
Republic of China
TEL: (886) 2 2716 9310
FAX: (886) 2 2715 3029