



HESTORE.HU

elektronikai alkatrész áruház

EN: This Datasheet is presented by the manufacturer.

Please visit our website for pricing and availability at www.hestore.hu.

DATA SHEET

Product Name Precision Metal Film Fixed Resistors

Part Name MF Series

File No. DIP-SP-002

Uniroyal Electronics Global Co., Ltd.

88#, Longteng Road, Economic & Technical Development Zone, Kunshan, Jiangsu, China

Tel +86 512 5763 1411 / 22 /33

Email marketing@uni-royal.cn

Manufacture Plant Uniroyal Electronics Industry Co., Ltd.

Aeon Technology Corporation

Royal Electronic Factory (Thailand) Co., Ltd.

Royal Technology (Thailand) Co., Ltd.

1. Scope

- 1.1 This datasheet is the characteristics of Precision Metal Film Fixed Resistors manufactured by UNI-ROYAL.
- 1.2 Flame Retardant type available
- 1.3 Low noise & voltage coefficient
- 1.4 Low temperature coefficient range
- 1.5 Multiple epoxy coating on vacuum-deposited metal film provides superior moisture protection
- 1.6 Nichrome resistive element provides stable performance in various environments
- 1.7 Compliant with RoHS directive.
- 1.8 Halogen free requirement.

2. Part No. System

The standard Part No. includes 14 digits with the following explanation:

- 2.1 Coated type, the 1st to 2nd digits are to indicate the product type .

Example: MF= Metal Film Fixed Resistors

- 2.2 The 3th digit is the special feature.

Example: 0= Standard product ; F= Flame Retardant ; I= Non-inductive

- 2.3 4th~6th digits:

- 2.3.1 This is to indicate the wattage or power rating. To dieting the size and the numbers,

The following codes are used; and please refer to the following chart for detail:

W=Normal Size; S=Small Size; U=Extra Small Size; “1”~“G”to denotes“1”~“16”as Hexadecimal:

1/16W~1/2W (<1W)

Wattage	1/2	1/3	1/4	1/5	1/6	1/8	0.6	0.4
Normal Size	W2	W3	W4	W5	W6	W8	/	/
Small Size	S2	S3	S4	S5	S6	S8	06	/
Extra Small Size	U2	U3	U4	U5	U6	U8	/	04

1W~16W (≥1W)

Wattage	1	2	3	5	7	8	9	10	15
Normal Size	1W	2W	3W	5W	7W	8W	9W	AW	FW
Small Size	1S	2S	3S	5S	7S	8S	9S	AS	FS
Extra Small Size	1U	2U	3U	5U	7U	8U	9U	AU	FU

- 2.3.2 For power rating less than 1 watt, the 4th digit will be the letters W, S or U to represent the size required & the 5th digit will be a number or a letter code.

Example: WA=1/10W; U2=1/2W-SS.

- 2.3.3 For power of 1 watt to 16 watt, the 4th digit will be a number or a letter code and the 5th digit will be the letters of W, S or U.

Example: AW=10W; 3S=3W-S

- 2.4 The 6th digit is to denote the Resistance Tolerance. The following letter code is to be used for indicating the standard Resistance Tolerance.

F=±1% G=±2% J=±5%

- 2.5 The 7th digits will be used to indicated the requested Temperature Coefficient.

(1) B=15PPM (2) B=25PPM (3) F=50PPM (4) G=100PPM (5) J=200PPM

- 2.6 The 8th to 11th digits is to denote the Resistance Value.

- 2.6.1 For the standard resistance values of E-24 series, the 8th digit is “0”, the 9th & 10th digits are to denote the significant figures of the resistance and the 11th digit is the number of zeros following;

For the standard resistance values of E-96 series, the 8th digit to the 10th digits is to denote the significant figures of the resistance and the 11th digit is the zeros following.

- 2.6.2 The following number s and the letter codes are to be used to indicate the number of zeros in the 11th digit:

0=10⁰ 1=10¹ 2=10² 3=10³ 4=10⁴ 5=10⁵ 6=10⁶ J=10⁻¹ K=10⁻² L=10⁻³ M=10⁻⁴

- 2.7 The 12th, 13th & 14th digits.

The 12th digit is to denote the Packaging Type with the following codes:

A=Tape/Box (Ammo pack) B=Bulk/Box T=Tape/Reel P=Tape/Box of PT-26 products

- 2.8 The 13th digit is normally to indicate the Packing Quantity of Tape/Box & Tape/Reel packaging types. The following letter code and number is to be used for some packing quantities:

A=500pcs B=2500pcs 1=1000pcs 2=2000pcs

- 2.9 For some items, the 14th digit alone can use to denote special features of additional information with the following codes:

0=NIL	P=Panasert type	1=Avisert type 1	2=Avisert type 2
3=Avisert type 3	8=PT-58mm	9=PT-64mm	7=Lead wire(H)38mm
A=PT-83mm	C=PT-73mm	D=PT-71mm	

3. Ordering Procedure

(Example: MF 1/4W ±1% 100Ω T/B-5000)

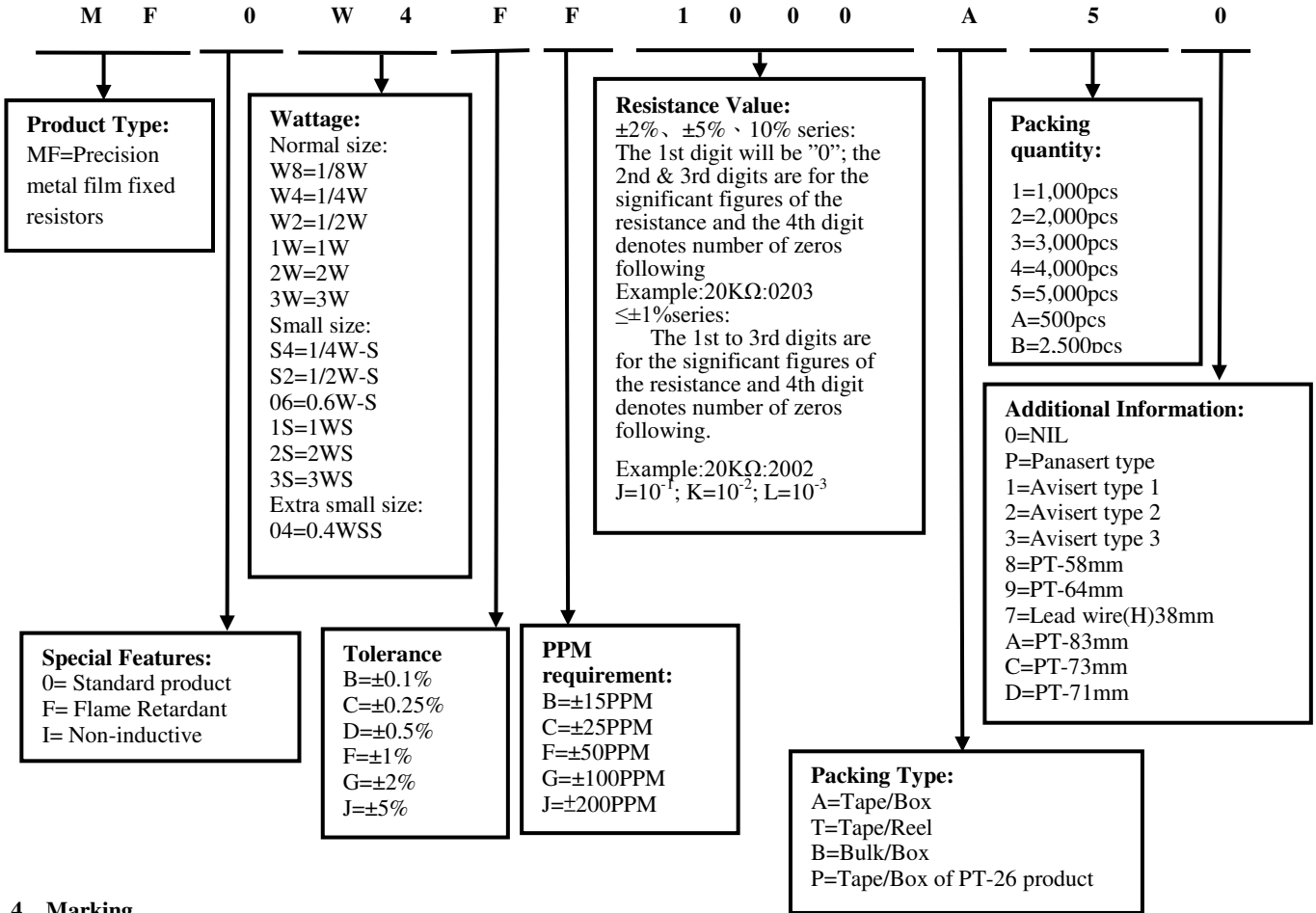

4. Marking

Resistors shall be marked with color coding
Colors shall be in accordance with JIS C 0802
For 1/8W,1/4WS,0.4WSS (±1%)

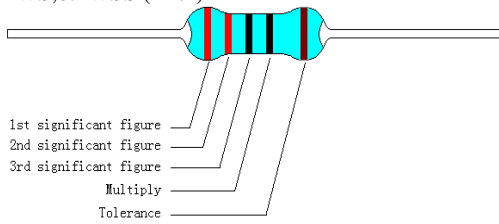

The other

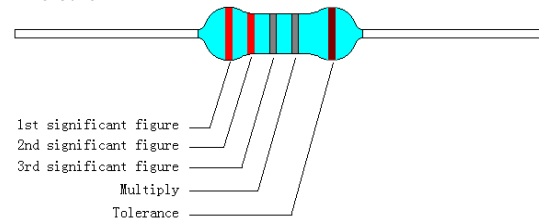

1st Band	2nd Band	3rd Band	4th Band	5th Band
Black = 0	Black = 0	Black = 0	Black = Multiply by 1 (10 ⁰)	Violet = ±0.1%
Brown = 1	Brown = 1	Brown = 1	Brown = Multiply by 10 (10 ¹)	Blue = ±0.25%
Red = 2	Red = 2	Red = 2	Red = Multiply by 100 (10 ²)	Green = ±0.5%
Orange = 3	Orange = 3	Orange = 3	Orange = Multiply by 1,000 (10 ³)	Brown = ±1%
Yellow = 4	Yellow = 4	Yellow = 4	Yellow = Multiply by 10,000 (10 ⁴)	
Green = 5	Green = 5	Green = 5	Green = Multiply by 100,000 (10 ⁵)	
Blue = 6	Blue = 6	Blue = 6	Blue = Multiply by 1,000,000 (10 ⁶)	
Violet = 7	Violet = 7	Violet = 7	Violet = Multiply by 10,000,000 (10 ⁷)	
Gray = 8	Gray = 8	Gray = 8	Gold = Multiply by 0.1 (10 ⁻¹)	
White = 9	White = 9	White = 9	Silver = Multiply by 0.01 (10 ⁻²)	

For 1/8W, 1/6W, 1/4WS, 0.4WSS ($\pm 2\%$, $\pm 5\%$)

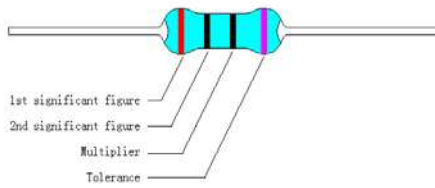

The other

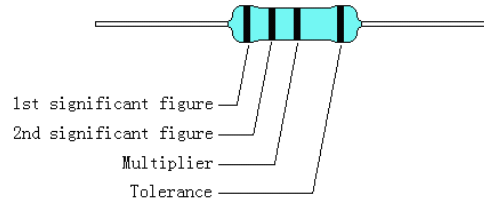

1st Band	2nd Band	3rd Band	4th Band
Black = 0	Black = 0	Black = Multiply by 1 (10^0)	Red = $\pm 2\%$
Brown = 1	Brown = 1	Brown = Multiply by 10 (10^1)	Gold = $\pm 5\%$
Red = 2	Red = 2	Red = Multiply by 100 (10^2)	Silver = $\pm 10\%$
Orange = 3	Orange = 3	Orange = Multiply by 1,000 (10^3)	
Yellow = 4	Yellow = 4	Yellow = Multiply by 10,000 (10^4)	
Green = 5	Green = 5	Green = Multiply by 100,000 (10^5)	
Blue = 6	Blue = 6	Blue = Multiply by 1,000,000 (10^6)	
Violet = 7	Violet = 7	Violet = Multiply by 10,000,000 (10^7)	
Gray = 8	Gray = 8	Gold = Multiply by 0.1 (10^{-1})	
White = 9	White = 9	Silver = Multiply by 0.01 (10^{-2})	

4.1 Label:

Label shall be marked with following items:

- (1) Type and style
- (2) Nominal resistance
- (3) Resistance tolerance
- (4) Quantity
- (5) Lot number
- (6) PPM

Example:

METAL FILM FIXED RESISTORS	
WATT: 1/4W	VAL: 100Ω
Q'TY: 5,000	TOL: 1%
LOT: 5021548	PPM: 50

5. Dimension

For 1/8W, 1/4WS, 0.4WSS

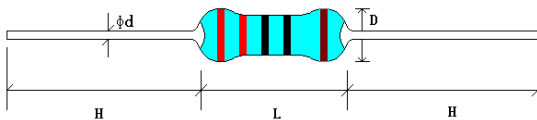

Other

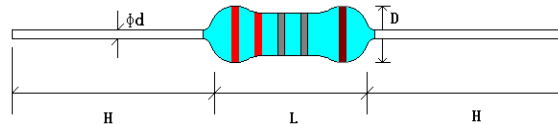

Type	Dimension(mm)					Max Working Voltage	Max Overload Voltage	Dielectric Withstanding Voltage	
	D	L	d ± 0.05	H ± 3	PT			Flammability	Flame Retardant
MF 1/8W	1.9 ± 0.3	3.3 ± 0.3	0.45	28	52	200V	400V	400V	200V
MF 1/4WS	1.9 ± 0.3	3.3 ± 0.3	0.45	28	52	200V	400V	400V	200V
MF 0.4WSS	1.9 ± 0.5	3.3 ± 0.3	0.45	28	52	200V	400V	400V	200V
MF 1/4W	2.2 ± 0.3	6.5 ± 1.0	0.54	28	52	250V	500V	500V	250V
MF 1/2WS	2.2 ± 0.5	6.5 ± 1.0	0.54	28	52	250V	500V	/	250V
MF 1/2W	3.5 ± 0.6	9.5 ± 1.0	0.54	28	52	350V	700V	700V	250V
MF 0.6WS	2.2 ± 0.5	6.5 ± 1.0	0.54	28	52	250V	500V	500V	250V
MF 1WS	3.5 ± 0.6	9.5 ± 1.0	0.54	28	52	350V	700V	700V	250V
MF 1W	4.5 ± 0.6	11.5 ± 1.0	0.70	25	52	500V	1000V	1000V	350V
MF 2WS	4.5 ± 0.6	11.5 ± 1.0	0.70	25	52	500V	1000V	1000V	350V
MF 2W	5.0 ± 0.6	15.5 ± 1.0	0.70	28	64	500V	1000V	1000V	350V
MF 3WS	5.0 ± 0.6	15.5 ± 1.0	0.70	28	64	500V	1000V	1000V	350V
MF 3W	6.0 ± 0.6	17.5 ± 1.0	0.75	28	64	500V	1000V	1000V	500V

6. Resistance Range

Type	Standard			Special Order		
	Tolerance	Resistance Range	TCR PPM/°C	Tolerance	Resistance Range	TCR PPM/°C
MF 1/8W MF 1/4WS MF 0.4WSS	±1%	10Ω~1MΩ	±50	±0.25%	51.1Ω~200KΩ	±15
	±2%	10Ω~1MΩ	±100	±0.5%	51.1Ω~511KΩ	±25
	±5%	1Ω~1MΩ	±200	±0.5%	51.1Ω~511KΩ	±50
MF 1/4W MF 1/2WS MF 0.6WS	±1%	10Ω~1MΩ	±50	±0.1%	10Ω~1MΩ	±15
	±2%	1Ω~1MΩ	±100	±0.25%	10Ω~1MΩ	±25
	±5%	1Ω~1MΩ	±200	±0.5%	10Ω~1MΩ	±50
MF 1/2W MF 1WS	±1%	10Ω~1MΩ	±50	±0.1%	100Ω~330KΩ	±15
	±2%	10Ω~1MΩ	±100	±0.25%	51.1Ω~511KΩ	±25
	±5%	1Ω~1MΩ	±200	±0.5%	10Ω~1MΩ	±50
MF 1W MF 2WS MF 2W MF 3WS MF 3W	±1%	51.1Ω~1MΩ	±50	±0.1%	100Ω~330KΩ	±15
	±2%	51.1Ω~1MΩ	±100	±0.25%	51.1Ω~511KΩ	±25
	±5%	1Ω~1MΩ	±200	±0.5%	51.1Ω~1MΩ	±50

7. Derating Curve

Power rating will change based on continuous load at ambient temperature from -55 to 155°C. It is constant between -55 to 70°C, and derate to zero when temperature rise from 70 to 155°C.

Voltage rating:

Resistors shall have a rated direct-current (DC) continuous working voltage or an approximate sine-wave root-mean-square (RMS) alternating-current (AC) continuous working voltage at commercial-line frequency and waveform corresponding to the power rating, as determined from the following formula:

$$RCWV = \sqrt{P \times R}$$

Remark: RCWV: Rating Continuous Working Voltage (Volt.) P: power rating (Watt) R: nominal resistance (Ω)

In no case shall the rated DC or RMS AC continuous working voltage be greater than the applicable maximum value.

The overload voltage is 2.5 times RCWV or Max. Overload voltage whichever is lower.

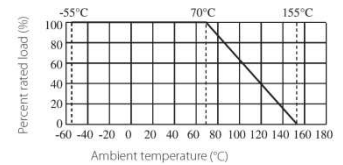

8. Structure

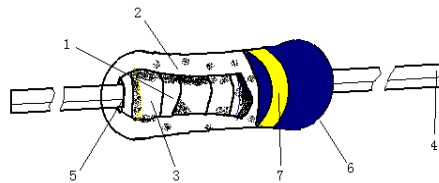

No.	Name	Material
1	Basic Body	Rod type ceramics
2	Resistor	Metal Film
3	End Cap	Cold steel plated with copper/tin
4	Lead Wire	Tin solder coated copper wire
5	Joint	By Welding
6	Coating	(1). Celluloid paint
		(2) Insulated Resin Color : Blue 1/2WS: Deep Green 0.6WS: Apple Green
7	Color Code	Epoxy resin

9. Performance Specification

Characteristic	Limits	Test Method (GB/T5729&JIS-C-5201&IEC60115-1)
Temperature Coefficient	Reference 6.0	4.8 Natural resistance changes per temp. Degree centigrade $\frac{R_2 - R_1}{R_1(t_2 - t_1)} \times 10^6 \text{ (PPM/}^\circ\text{C)}$ R ₁ : Resistance Value at room temperature (t ₁) ; R ₂ : Resistance at test temperature (t ₂) t ₁ : +25°C or specified room temperature t ₂ : Test temperature (-55°C or 125°C)
Short-time overload	$\Delta R/R \leq \pm(0.5\% + 0.05 \Omega)$, with no evidence of mechanical damage	4.13 Permanent resistance change after the application of a potential of 2.5 times RCWV or Max. Overload Voltage whichever less for 5 seconds.
Dielectric withstanding voltage	No evidence of flashover mechanical damage, arcing or insulation break down.	4.7 Resistors shall be clamped in the trough of a 90° metallic v-block and shall be tested at ac potential respectively specified in the above list for 60-70 seconds.
Pulse overload	$\Delta R/R \leq \pm(1\% + 0.05)$, with no evidence of mechanical damage	4.28 Resistance change after 10,000 cycles (1 second "ON", 25 seconds "OFF") at 4 times RCWV of RCWV or Max. Overload whichever less.
Resistance to soldering heat	$\Delta R/R \leq \pm(1\% + 0.05 \Omega)$ with no evidence of mechanical damage	4.18 Permanent resistance change when leads immersed to a point 2.0-2.5mm from the body in 260°C ± 5°C solder for 10 ± 1 seconds.
Resistance to solvent	No deterioration of protective coatings & markings	4.29 Specimens shall be immersed in a bath of IPA completely for a 5 ± 0.5 minutes using ultrasonic test equipment.
Terminal strength	No evidence of mechanical damage	4.16 Direct load: Resistance to a 2.5 kg direct load for 10 seconds in the direction of the longitudinal axis of the terminal leads. Twist test: Terminal leads shall be bent through 90° at a point of about 6mm from the body of the resistor and shall be rotated through 360° about the original axis of the bent terminal in alternating direction for a total of 3 rotations.
Solderability	Coverage must be over 95%.	4.17 The area covered with a new, smooth, clean, shiny and continuous surface free from concentrated pinholes. Test temp. Of solder: 245°C ± 3°C Dwell time in solder: 2~3 seconds.
Rapid change of temperature	$\Delta R/R \leq \pm(1\% + 0.05 \Omega)$ with no evidence of mechanical damage	4.19 30 min at -55 °C and 30 min at 155°C; 100 cycles.
Load life in humidity	Normal type: $\Delta R/R \leq \pm 1.5\%$; flame retardant type: $\Delta R/R \leq \pm 5\%$	7.9 resistance change after 1,000 hours (1.5 hours "ON", 0.5 hour "OFF") at RCWV or Max. Working Voltage whichever less in a humidity test chamber controlled at 40°C ± 2°C and 90 to 95% relative humidity.
Load life	Normal type: $\Delta R/R \leq \pm 1.5\%$; flame retardant type: $\Delta R/R \leq \pm 5\%$	4.25.1 Permanent resistance change after 1,000 hours operating at RCWV or Max. Working Voltage whichever less with duty cycle of 1.5 hours "ON", 0.5 hour "OFF" at 70°C ± 2°C ambient.
Low Temperature Storage	Normal type: $\Delta R/R \leq \pm 1.5\%$; flame retardant type: $\Delta R/R \leq \pm 5\%$	IEC 60068-2-1 (Aa) -55°C, for 2H.
High Temperature Exposure	Normal type: $\Delta R/R \leq \pm 1.5\%$; flame retardant type: $\Delta R/R \leq \pm 5\%$	MIL-STD-202 108A 155°C, for 16H.

10. Packing

10.1 Tapes in Box Packing

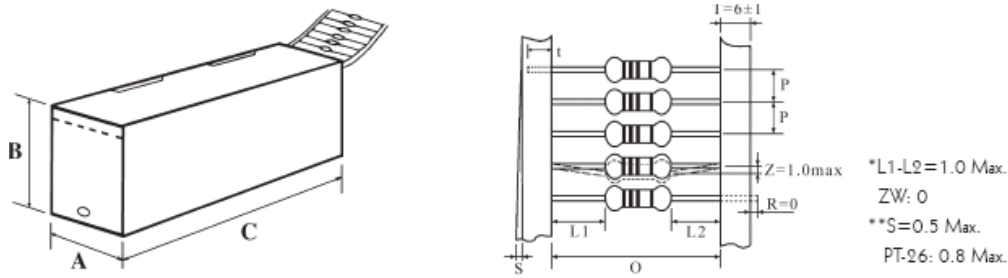

Dimension of T/B (mm)

Part No.	O	P	A±5	B±5	C±5	Qty/Box
MF 1/8W	52±1	5±0.3	75	70	255	5,000pcs
MF 1/4WS	52±1	5±0.3	75	70	255	5,000pcs
MF 0.4WSS	52±1	5±0.3	75	70	255	5,000pcs
MF 1/4W	52±1	5±0.3	75	98	255	5,000pcs
MF 1/2WS	52±1	5±0.3	75	98	255	5,000pcs
MF 0.6WS	52±1	5±0.3	75	98	255	5,000pcs
MF 1/2W	52±1	5±0.3	75	45	255	1,000pcs
MF 1WS	52±1	5±0.3	75	45	255	1,000pcs
MF 1W	52±1	5±0.3	80	82	255	1,000pcs
MF 2WS	52±1	5±0.3	80	82	255	1,000pcs
MF 2W	64±5	10±0.5	90	119	255	1000pcs
MF 3WS	64±5	10±0.5	90	119	255	1000pcs
MF 3W	64±5	10±0.5	90	88	255	500pcs

10.2 Tapes in Reel Packing

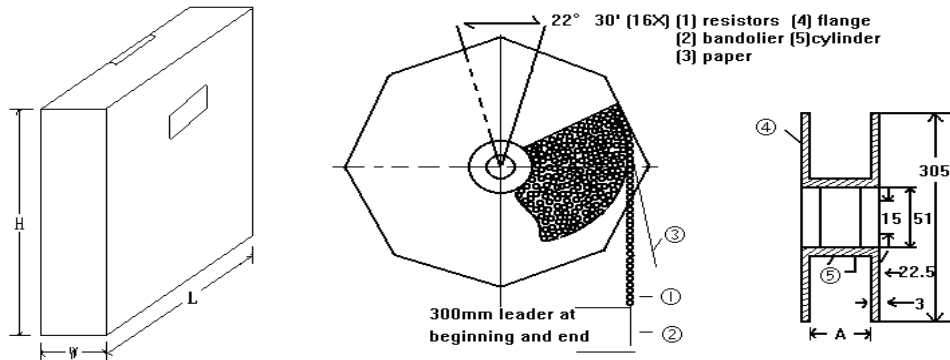

Dimension of Reel (mm)

Part No.	O	A	W±5	H±5	L±5	Qty/Box
MF 1/8W	52±1	73±2	85	294	293	5,000pcs
MF 1/4WS	52±1	73±2	85	294	293	5,000pcs
MF 0.4WSS	52±1	73±2	85	294	293	5,000pcs
MF 1/4W	52±1	73±2	85	294	293	5,000pcs
MF 1/2WS	52±1	73±2	85	294	293	5,000pcs
MF 1/2W	52±1	73±2	85	294	293	4,000pcs
MF 0.6WS	52±1	73±2	85	294	293	5,000pcs
MF 1WS	52±1	73±2	85	294	293	4,000pcs
MF 1W	52±1	73±2	85	294	293	2,500pcs
MF 2WS	52±1	73±2	85	294	293	2,500pcs
MF 2W	64±5	80±5	95	294	293	1,000pcs
MF 3WS	64±5	80±5	95	294	293	1,000pcs
MF 3W	64±5	80±5	95	294	293	1,000pcs

10.3 Bulk in Box Packing

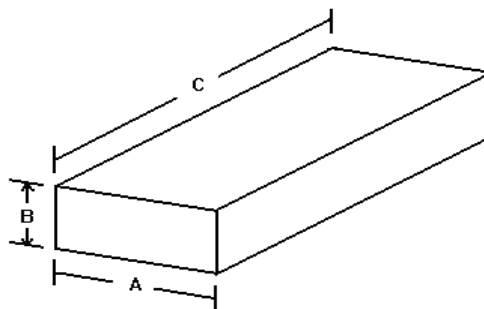

Dimension of Box (mm)

Part No.	A±5	B±5	C±5	Qty/Box
MF 1/8W	140	80	240	1,000/20,000pcs
MF 1/4WS	140	80	240	1,000/20,000pcs
MF 0.4WSS	140	80	240	1,000/20,000pcs
MF 1/4W	140	80	240	500/10,000pcs
MF 1/2WS	140	80	240	500/10,000pcs
MF 1/2W	140	80	240	200/4,000pcs
MF 0.6WS	140	80	240	500/10,000pcs
MF 1WS	140	80	240	200/4,000pcs
MF 1W	140	80	240	100/2,500pcs
MF 2WS	140	80	240	100/2,500pcs
MF 2W	140	80	240	100/1,500pcs
MF 3WS	140	80	240	100/1,500pcs
MF 3W	140	80	240	100/1,000pcs

11. Note

- 11.1. UNI-ROYAL recommend products store in warehouse with temperature between 15 to 35°C under humidity between 25 to 75%RH.
Even under storage conditions recommended above, solder ability of products will be degraded stored over 1 year old.
- 11.2. Cartons must be placed in correct direction which indicated on carton, otherwise the reel or wire will be deformed.
- 11.3. Storage conditions as below are inappropriate:
- Stored in high electrostatic environment
 - Stored in direct sunshine, rain, snow or condensation.
 - Exposed to sea wind or corrosive gases, such as Cl₂, H₂S, NH₃, SO₂, NO₂, Br etc.

12. Record

Version	Description	Page	Date	Amended by	Checked by
1	First version	1~7	Mar.20, 2018	Haiyan Chen	Nana Chen
2	Modify coating color	5	May.08, 2018	Haiyan Chen	Nana Chen
3	Modify characteristic	5~6	Feb.18, 2019	Haiyan Chen	Yuhua Xu
4	Modify the temperature coefficient test conditions	4	Oct.28, 2022	Haiyan Chen	Yuhua Xu
5	1.Increased flame retardant withstand voltage value 2. Increased standard color code system	3	Aug.07, 2023	Haiyan Chen	Yuhua Xu
6	Modify the dimension	4	Mar.25, 2024	Haiyan Chen	Yuhua Xu
7	Modify the packaging size and the number of packages	7~8	Jun.23, 2025	Haiyan Chen	Yuhua Xu