



HESTORE.HU

elektronikai alkatrész áruház

EN: This Datasheet is presented by the manufacturer.

Please visit our website for pricing and availability at www.hestore.hu.

TP65H070G4PS

650V SuperGaN® GaN FET in TO-220 (source tab)

Description

The TP65H070G4PS 650V, 72mΩ Gallium Nitride (GaN) FET is a normally-off device. It combines a state-of-the-art high-voltage GaN HEMT with a low-voltage silicon MOSFET to offer superior performance, standard drive, ease of adoption and reliability.

The Gen IV SuperGaN® platform uses advanced epi and patented design technologies to simplify manufacturability while improving efficiency over silicon via lower gate charge, output capacitance, crossover loss, and reverse recovery charge.

Benefits

- Superior normally off architecture with D-mode GaN HEMT
- Compatible with standard silicon drivers
- Enhanced noise immunity with a 4V threshold voltage with no negative gate drive required
- Enables high-efficiency, high power density, and reliable power conversion
- Facilitates cost-effective GaN adoption reducing system size, weight, and costs

Product and Schematic Diagrams

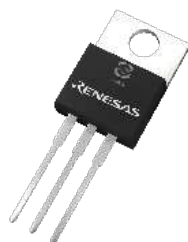

TP65H070G4PS TO-220

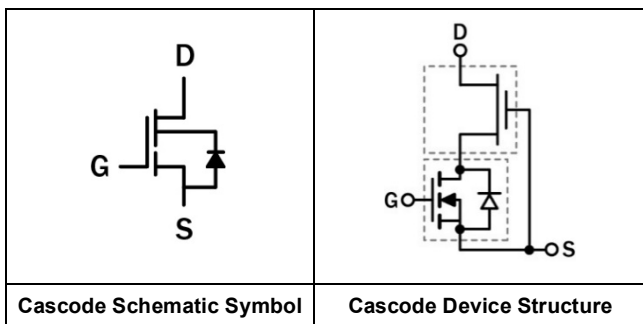

Features

- Ultra-fast switching Gen IV plus GaN
- JEDEC-qualified GaN technology
- Dynamic RDS(on)eff production tested
- Reduced crossover loss
- Negligible Qrr
- RoHS compliant and Halogen-free packaging

Applications

- AI datacenter and telecom power supplies
- E-mobility charging
- PV inverter
- UPS
- BESS



Specifications

V _{DS} (V)	650
V _{DSS(TR)} (V) maximum	800
R _{DS(on)} (mΩ) maximum ^[1]	85
Q _{OSS} (nC) typical	78
Q _G (nC) typical	9

1. Dynamic R_{DS(on)} (see Figure 17 and Figure 18)

Contents

1. Pin Information	3
1.1 Pin Assignments.....	3
1.2 Pin Descriptions.....	3
2. Specifications	4
2.1 Absolute Maximum Ratings.....	4
2.2 Thermal Specifications.....	4
2.3 Electrical Specifications – Forward Device.....	5
2.4 Electrical Specifications – Reverse Device.....	6
3. Typical Performance Graphs	7
4. Test Circuits and Waveforms	10
5. Package Outline Drawings	11
6. Related Information	12
7. Ordering Information	12
8. Revision History	12

Figures

Figure 1. Pin Assignments.....	3
Figure 2. Typical Output Characteristics, $T_J = 25^\circ\text{C}$ Parameter: V_{GS}	7
Figure 3. Typical Output Characteristics, $T_J = 150^\circ\text{C}$ Parameter: V_{GS}	7
Figure 4. Typical Transfer Characteristics $V_{DS} = 10\text{V}$, Parameter: T_J	7
Figure 5. Normalized On-resistance $I_D = 18\text{A}$, $V_{GS} = 10\text{V}$	7
Figure 6. Typical Capacitance $V_{GS} = 0\text{V}$, $f = 1\text{MHz}$	8
Figure 7. Typical C_{OSS} Stored Energy.....	8
Figure 8. Typical Q_{OSS}	8
Figure 9. Typical Gate Charge.....	8
Figure 10. Power Dissipation.....	9
Figure 11. Current Derating.....	9
Figure 12. Forward Characteristics of Rev. Diode.....	9
Figure 13. Transient Thermal Resistance.....	9
Figure 14. Safe Operating Area $T_C = 25^\circ\text{C}$	9
Figure 15. Switching Time Test Circuit.....	10
Figure 16. Switching Time Waveform.....	10
Figure 17. Dynamic $R_{DS(on)eff}$ Test Circuit.....	10
Figure 18. Dynamic $R_{DS(on)eff}$ Waveform.....	10
Figure 19. TO-220 Package Outline Drawing.....	11

1. Pin Information

1.1 Pin Assignments

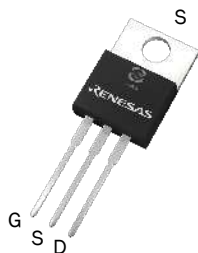

Figure 1. Pin Assignments

1.2 Pin Descriptions

Pin Name	Description
D	Drain.
S	Source.
G	Gate.

2. Specifications

2.1 Absolute Maximum Ratings

$T_c = 25^\circ\text{C}$ unless otherwise stated.

Caution: Do not operate at or near the maximum ratings listed for extended periods of time. Exposure to such conditions can adversely impact product reliability and result in failures not covered by warranty.

Symbol	Parameter	Limit Value	Unit
V_{DSS}	Drain to source voltage ($T_J = -55^\circ\text{C}$ to 150°C)	650	V
$V_{DSS(TR)}$	Transient drain to source voltage ^[1]	800	V
V_{GSS}	Gate to source voltage	+20	V
P_D	Maximum power dissipation at $T_c = 25^\circ\text{C}$	96	W
I_D	Continuous drain current at $T_c = 25^\circ\text{C}$	29	A
	Continuous drain current at $T_c = 100^\circ\text{C}$	18.4	A
I_{DM}	Pulsed drain current (pulse width: $10\mu\text{s}$)	120	A
T_J	Junction operating temperature	-55 to +150	$^\circ\text{C}$
T_s	Storage temperature	-55 to +150	$^\circ\text{C}$
T_{SOLD}	Reflow soldering temperature ^[2]	260	$^\circ\text{C}$

1. In off-state, spike duration < $30\mu\text{s}$, non-repetitive.
2. Reflow MSL3.

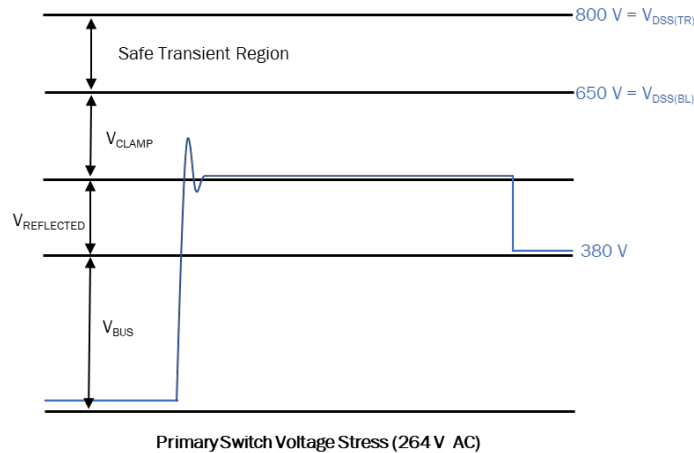

2.2 Thermal Specifications

Symbol	Condition	Typical Value	Unit
$R_{\theta JC}$	Junction-to-case	1	$^\circ\text{C}/\text{W}$
$R_{\theta JA}$	Junction-to-ambient ^[1]	62	

2.3 Electrical Specifications – Forward Device

T_J = 25°C unless otherwise stated.

Symbol	Parameter	Test Conditions	Minimum	Typical	Maximum	Unit
V _{DSS(BL)}	Maximum drain-source voltage	V _{GS} = 0V, I _D = 1mA	650	-	-	V
V _{GS(th)}	Gate threshold voltage	V _{DS} = V _{GS} , I _D = 0.7mA	3.3	4	4.8	V
R _{DS(on)eff}	Drain-source on-resistance ^[1]	V _{GS} = 10V, I _D = 18A, T _J = 25°C	-	72	85	mΩ
		V _{GS} = 10V, I _D = 18A, T _J = 150°C	-	148	-	
I _{DSS}	Drain-to-source leakage current	V _{DS} = 650V, V _{GS} = 0V, T _J = 25°C	-	1.2	12	μA
		V _{DS} = 650V, V _{GS} = 0V, T _J = 150°C	-	8	-	
I _{GSS}	Gate-to-source forward leakage current	V _{GS} = 20V	-	-	100	nA
	Gate-to-source reverse leakage current	V _{GS} = -20V	-	-	-100	
C _{ISS}	Input capacitance	V _{GS} = 0V, V _{DS} = 400V, f = 500kHz	-	638	-	pF
C _{OSS}	Output capacitance		-	72	-	
C _{RSS}	Reverse transfer capacitance		-	2	-	
C _{O(er)}	Output capacitance, energy related ^[2]	V _{GS} = 0V, V _{DS} = 0V to 400V	-	105	-	pF
C _{O(tr)}	Output capacitance, time related ^[3]		-	194	-	
Q _G	Total gate charge	V _{DS} = 400V, V _{GS} = 0V to 10V, I _D = 18A	-	9	-	nC
Q _{GS}	Gate-source charge		-	3.7	-	
Q _{GD}	Gate-drain charge		-	2.4	-	
Q _{OSS}	Output charge	V _{GS} = 0V, V _{DS} = 0V to 400V	-	78	-	nC
t _{D(on)}	Turn-on delay	V _{DS} = 400V, V _{GS} = 0V to 12V, I _D = 18A, R _G = 50Ω (see Figure 15)	-	43.4	-	ns
t _R	Rise time		-	6.2	-	
t _{D(off)}	Turn-off delay		-	56	-	
t _F	Fall time		-	7.2	-	

1. Dynamic R_{DS(on)}, 100% tested; see Figure 17 and Figure 18 for conditions.
2. Equivalent capacitance to give same stored energy from 0V to 400V.
3. Equivalent capacitance to give same charging time from 0V to 400V.

2.4 Electrical Specifications – Reverse Device

$T_J = 25^\circ\text{C}$ unless otherwise stated.

Symbol	Parameter	Test Conditions	Minimum	Typical	Maximum	Unit
I_S	Reverse current	$V_{GS} = 0V, T_C = 100^\circ\text{C},$ $\leq 25\%$ duty cycle	-	-	18	A
V_{SD}	Reverse voltage ^[1]	$V_{GS} = 0V, I_S = 18A$	1.6	1.9	2.2	V
		$V_{GS} = 0V, I_S = 9A$	1.2	1.4	1.6	

1. Includes dynamic $R_{DS(on)}$ effect.

Note: Reverse recovery charge is negligible, enabled by the LV Si FET technology

3. Typical Performance Graphs

$T_c = 25^\circ\text{C}$ unless otherwise stated.

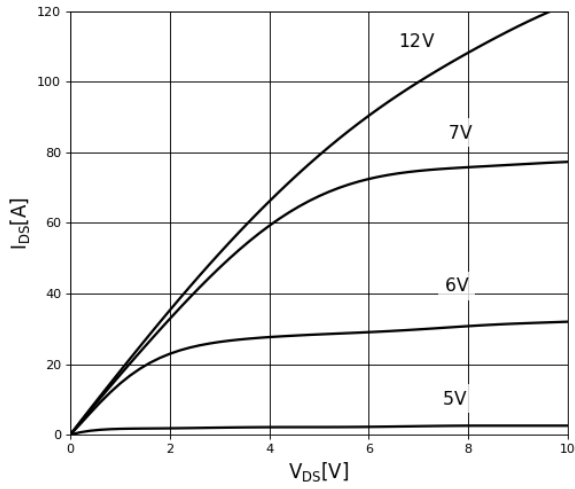

Figure 2. Typical Output Characteristics, $T_J = 25^\circ\text{C}$
Parameter: V_{GS}

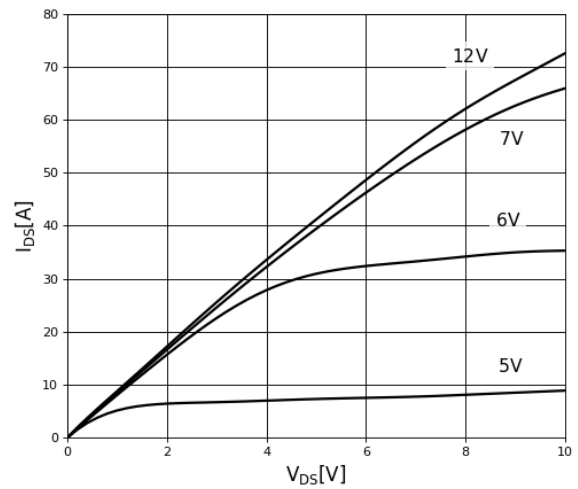

Figure 3. Typical Output Characteristics, $T_J = 150^\circ\text{C}$
Parameter: V_{GS}

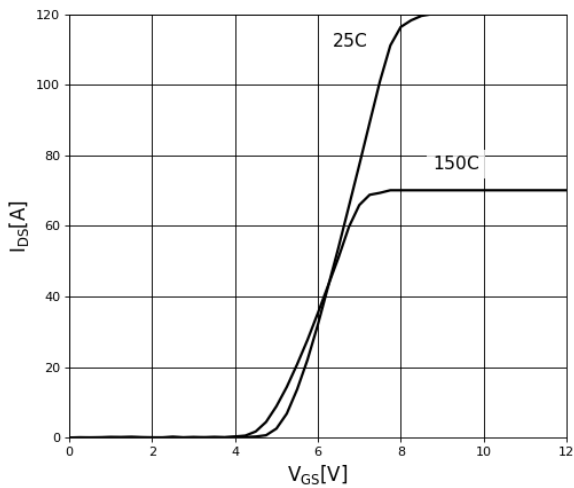

Figure 4. Typical Transfer Characteristics
 $V_{DS} = 10\text{V}$, Parameter: T_J

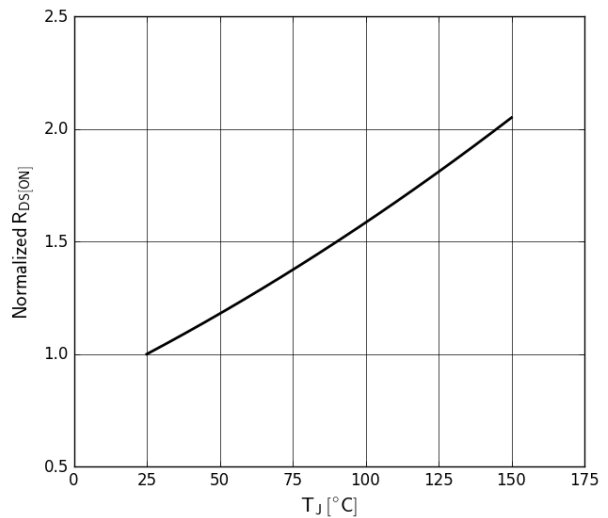

Figure 5. Normalized On-resistance
 $I_D = 18\text{A}$, $V_{GS} = 10\text{V}$

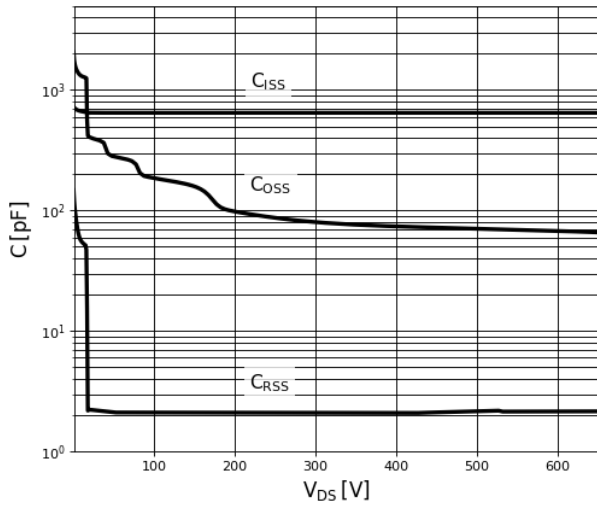

Figure 6. Typical Capacitance

$V_{GS} = 0V, f = 1MHz$

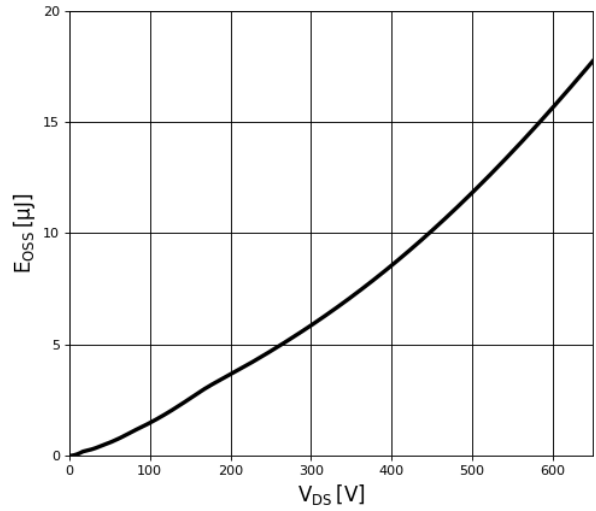

Figure 7. Typical Coss Stored Energy

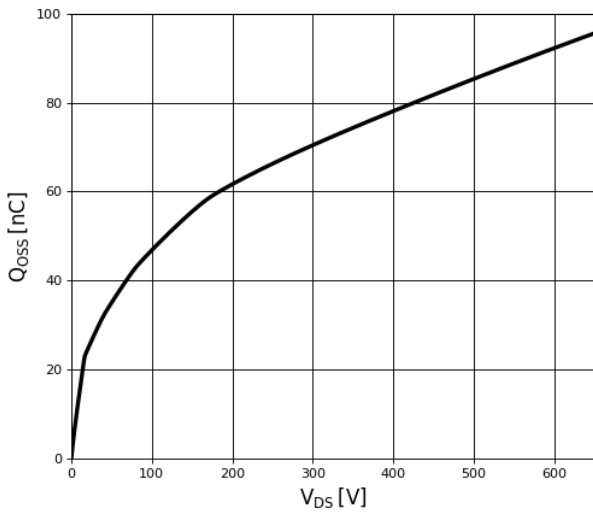

Figure 8. Typical Qoss

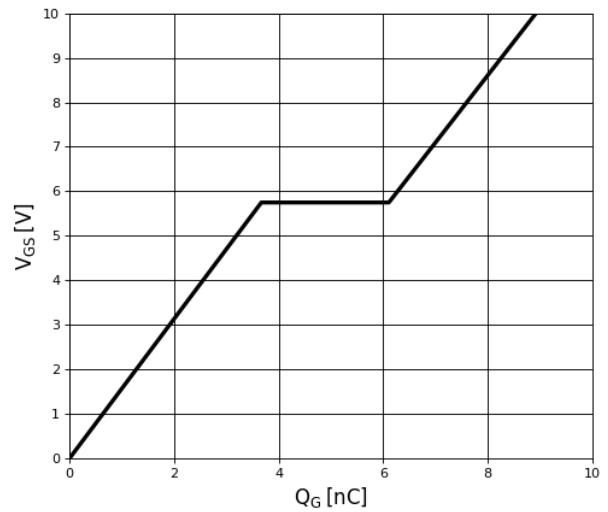

Figure 9. Typical Gate Charge

$I_{DS} = 18A, V_{DS} = 400V$

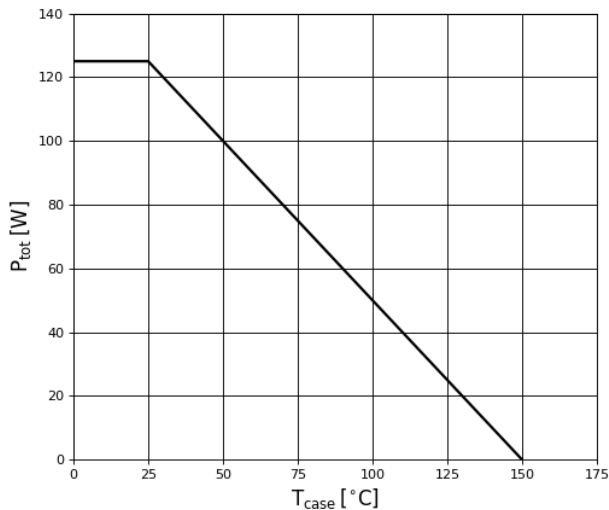

Figure 10. Power Dissipation

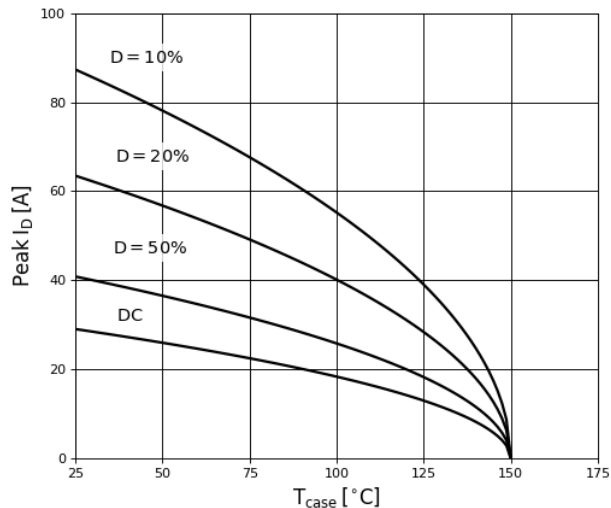

Figure 11. Current Derating

Pulse width $\leq 10\mu s$, $V_{GS} \geq 10V$

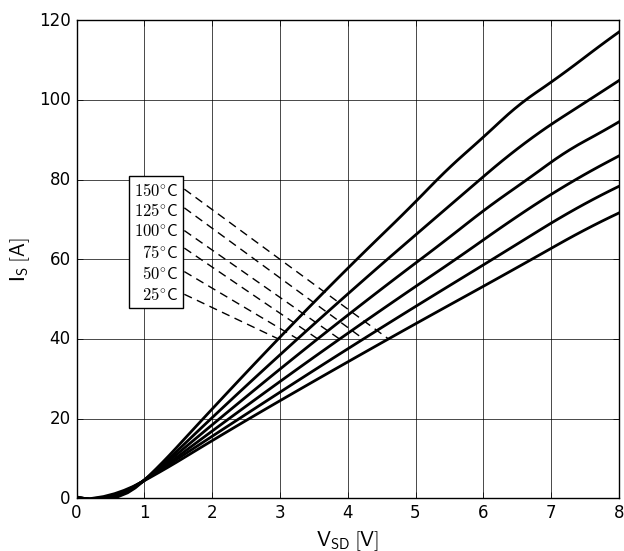

Figure 12. Forward Characteristics of Rev. Diode

$I_S = f(V_{SD})$, Parameter: T_J

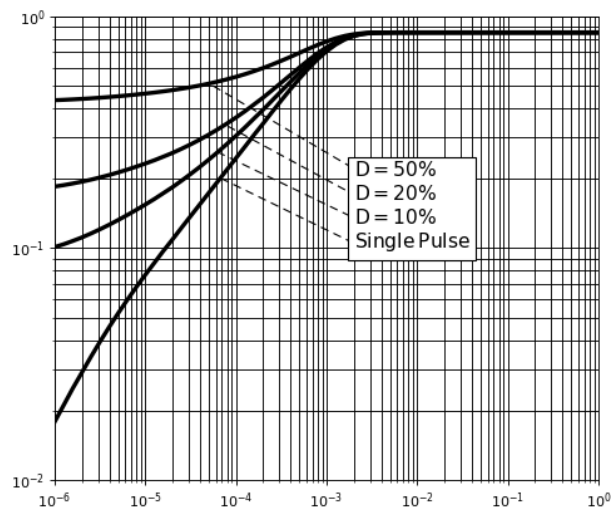

Figure 13. Transient Thermal Resistance

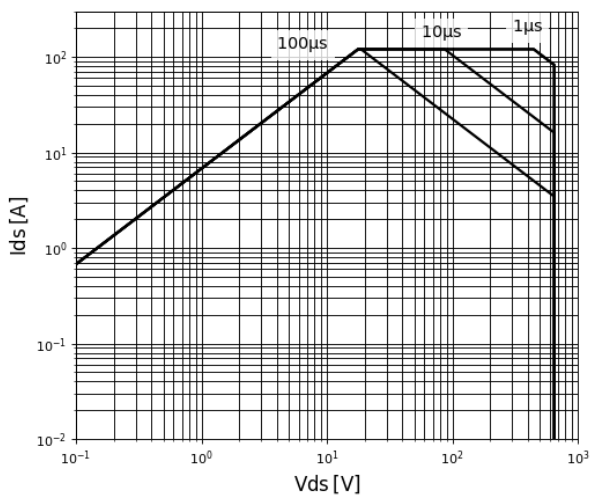

Figure 14. Safe Operating Area $T_C = 25^\circ C$

4. Test Circuits and Waveforms

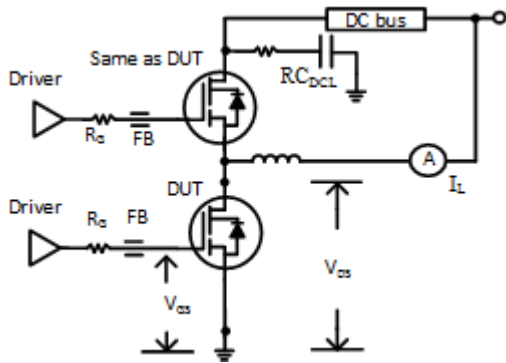

Figure 15. Switching Time Test Circuit

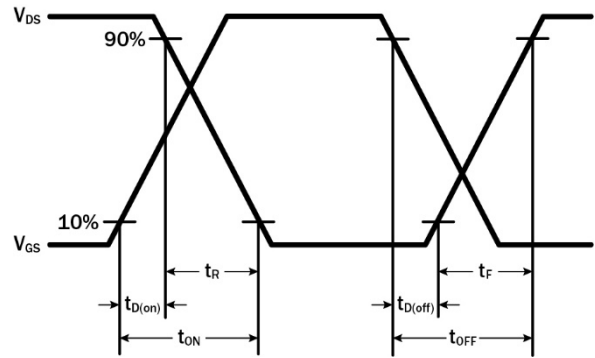

Figure 16. Switching Time Waveform

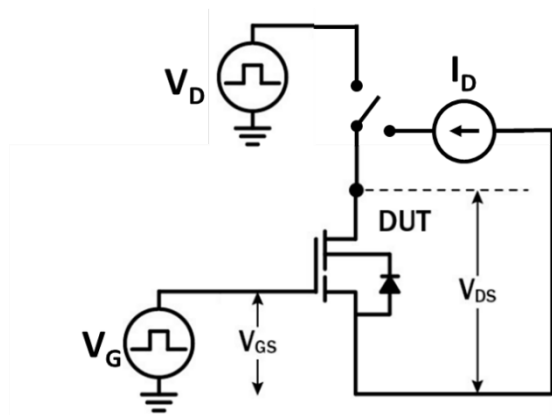

Figure 17. Dynamic $R_{DS(on)eff}$ Test Circuit

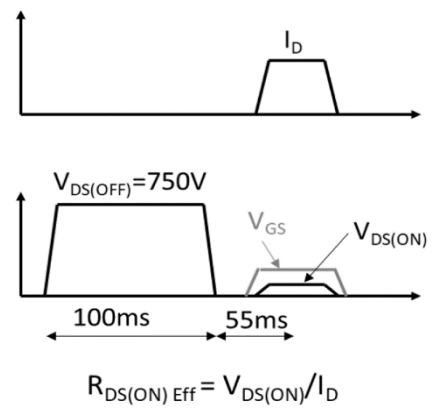

Figure 18. Dynamic $R_{DS(on)eff}$ Waveform

5. Package Outline Drawings

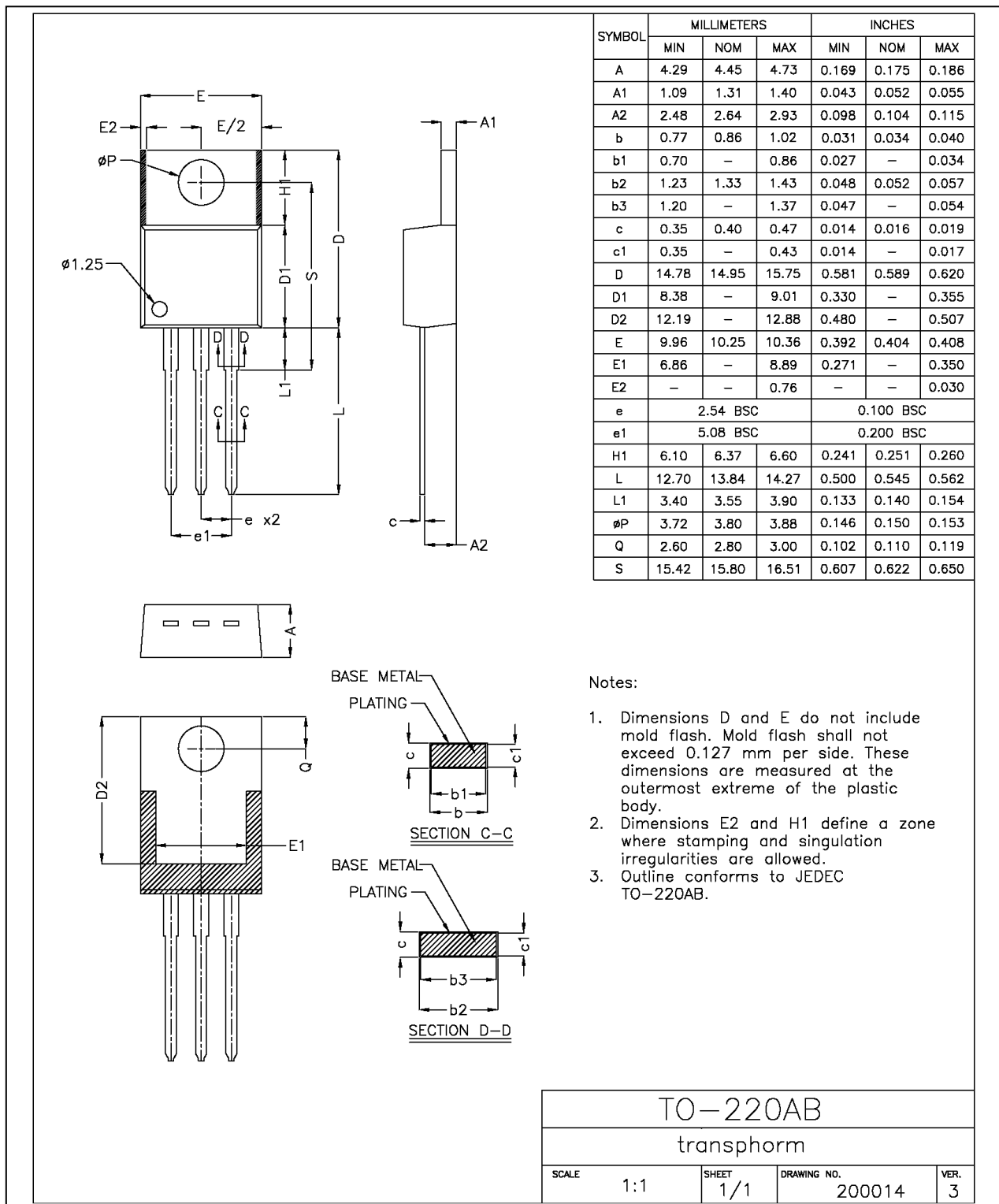

Figure 19. TO-220 Package Outline Drawing

6. Related Information

All technical documents for Renesas GaN Power devices are accessible from the [GaN Power Solutions](#) page.

7. Ordering Information

Part Number	Package Description	Package Configuration
TP65H070G4PS	TO-220	Source tab

8. Revision History

Revision	Date	Description
2.01	Jun 8, 2026	Updated VSD to 25°C data.
2.00	Nov 25, 2025	Updated the document's formatting; no technical changes were completed.
1.00	Dec 4, 2023	Initial release.

IMPORTANT NOTICE AND DISCLAIMER

RENESAS ELECTRONICS CORPORATION AND ITS SUBSIDIARIES (“RENESAS”) PROVIDES TECHNICAL SPECIFICATIONS AND RELIABILITY DATA (INCLUDING DATASHEETS), DESIGN RESOURCES (INCLUDING REFERENCE DESIGNS), APPLICATION OR OTHER DESIGN ADVICE, WEB TOOLS, SAFETY INFORMATION, AND OTHER RESOURCES “AS IS” AND WITH ALL FAULTS, AND DISCLAIMS ALL WARRANTIES, EXPRESS OR IMPLIED, INCLUDING, WITHOUT LIMITATION, ANY IMPLIED WARRANTIES OF MERCHANTABILITY, FITNESS FOR A PARTICULAR PURPOSE, OR NON-INFRINGEMENT OF THIRD-PARTY INTELLECTUAL PROPERTY RIGHTS.

These resources are intended for developers who are designing with Renesas products. You are solely responsible for (1) selecting the appropriate products for your application, (2) designing, validating, and testing your application, and (3) ensuring your application meets applicable standards, and any other safety, security, or other requirements. These resources are subject to change without notice. Renesas grants you permission to use these resources only to develop an application that uses Renesas products. Other reproduction or use of these resources is strictly prohibited. No license is granted to any other Renesas intellectual property or to any third-party intellectual property. Renesas disclaims responsibility for, and you will fully indemnify Renesas and its representatives against, any claims, damages, costs, losses, or liabilities arising from your use of these resources. Renesas' products are provided only subject to Renesas' Terms and Conditions of Sale or other applicable terms agreed to in writing. No use of any Renesas resources expands or otherwise alters any applicable warranties or warranty disclaimers for these products.

(Disclaimer Rev.1.01)

Corporate Headquarters

TOYOSU FORESIA, 3-2-24 Toyosu,
Koto-ku, Tokyo 135-0061, Japan
www.renesas.com

Trademarks

Renesas and the Renesas logo are trademarks of Renesas Electronics Corporation. All trademarks and registered trademarks are the property of their respective owners.

Contact Information

For further information on a product, technology, the most up-to-date version of a document, or your nearest sales office, please visit www.renesas.com/contact-us/.