



**HESTORE.HU**  
elektronikai alkatrész áruház

**EN:** This Datasheet is presented by the manufacturer.

Please visit our website for pricing and availability at [www.hestore.hu](http://www.hestore.hu).

Power Relays ( Over 2 A )  
**HE-S RELAYS**

Product Catalog

**IN Your  
Future**

# HE-S RELAYS

Compact size 2 Form A and 2 Form A 1 Form B 40 A power relays for energy management and industrial equipment

[Protective construction] Flux-resistant

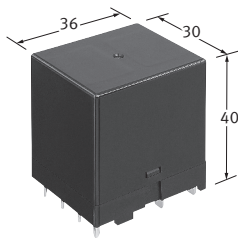

(Unit : mm)

## FEATURES

- High-capacity
- Max. switching current: 40 A
- Detection of main contact welding makes it possible to construct a safety circuit ( 2 Form A and 2 Form A 1 Form B )
- Compact size
- Low operating power: 1,880 mW ( holding power: 170 mW )
- Contact gap: 3.2 mm ( VDE0126 compliant )
- Mirror contact mechanisms: Compliant with EN60947-4-1 mirror contact

## TYPICAL APPLICATIONS

- Photovoltaic power generation system
- UPS ( Uninterruptible power supply )
- Inverter
- Industrial air conditioner
- Industrial equipment

## DETAILS FEATURES

### Expected electrical life ( resistive load )

Form A contact	Standard type	Long life type
20 A 277 V AC	100 × 10 <sup>3</sup> ope.	200 × 10 <sup>3</sup> ope.
30 A 220 V AC	—	100 × 10 <sup>3</sup> ope.
35 A 277 V AC	30 × 10 <sup>3</sup> ope.	50 × 10 <sup>3</sup> ope.
40 A 277 V AC	10 <sup>3</sup> ope.	10 <sup>3</sup> ope.
5 A 110 V DC	10 × 10 <sup>3</sup> ope.	10 × 10 <sup>3</sup> ope.

### Contact gap: 3.2 mm

Compliant with European photovoltaic standard VDE0126  
Compliant with EN61810-1 2.5 kV surge withstand voltage ( between contacts )

### Contact gap ( initial )

Form A contact	Min. 3.2 mm each contact
Form B contact	Min. 0.7 mm Min. 0.5 mm ( When Form A contact welded )

### Reduced coil holding voltage\* contributes to saving energy of equipment

The coil holding voltage can be reduced up to 30 % V of the rated coil voltage. This equals to operating power of approximately 170 mW, which contributes equipment energy savings.

\* Coil holding voltage is the coil voltage after 100 ms from the applied rated coil voltage.

### Insulation distance ( initial )

Between Form A contact and coil	Min. 11.0 mm ( Clearance/Creepage )
Between Form B contact and coil	Min. 3.2 mm ( Clearance/Creepage )
Between Form A contact sets	Min. 8.2 mm ( Clearance/Creepage )
Between Form A contact and Form B contact	Min. 12.8 mm ( Clearance/Creepage )

# Power Relays ( Over 2 A ) HE-S RELAYS

## Mirror contact mechanisms ( Compliant with EN60947-4-1 mirror contact )

Detection of main contact welding makes it possible to construct a safety circuit.

- Designed so that Form A contact and Form B contact will not close at the same time.
- When Form A contact welded, Form B contact gap of at least 0.5 mm is maintained.

Note) Form B contact, when used to monitor the condition of Form A contact, can be used exclusively as an auxiliary contact.

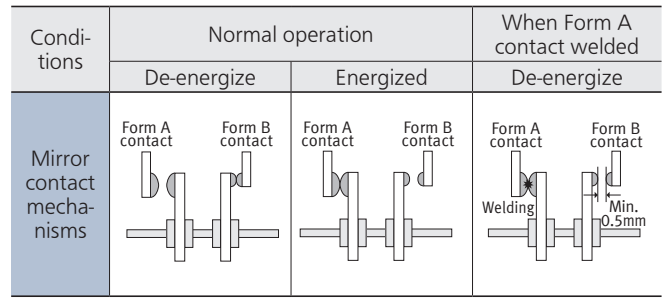

## ORDERING INFORMATION ( PART NO. )

**AHES**

**9**

- Contact arrangement/Operating function  
3 : 2 Form A Single side stable  
4 : 2 Form A 1 Form B Single side stable

- Contact specifications  
1 : Standard type  
2 : Long life type

- Terminals shape  
9 : PC board terminal

- Rated coil voltage (DC)  
0 : 6V  
1 : 12V  
2 : 24V  
3 : 48V  
5 : 9V

- Approved standards  
Q : UL/C-UL, VDE, CQC  
Nil : UL/C-UL, VDE

## TYPES

### PC board terminal

Contact arrangement	Rated coil voltage	Part No.		Standard packing	
		Standard type	Long life type	Inner carton	Outer carton
2 Form A ( 2a )	6 V DC	AHES3190 ( Q )	AHES3290 ( Q )	25 pcs.	100 pcs.
	9 V DC	AHES3195 ( Q )	AHES3295 ( Q )		
	12 V DC	AHES3191 ( Q )	AHES3291 ( Q )		
	24 V DC	AHES3192 ( Q )	AHES3292 ( Q )		
	48 V DC	AHES3193 ( Q )	AHES3293 ( Q )		
2 Form A 1 Form B ( 2a1b )	6 V DC	AHES4190 ( Q )	AHES4290 ( Q )		
	9 V DC	AHES4195 ( Q )	AHES4295 ( Q )		
	12 V DC	AHES4191 ( Q )	AHES4291 ( Q )		
	24 V DC	AHES4192 ( Q )	AHES4292 ( Q )		
	48 V DC	AHES4193 ( Q )	AHES4293 ( Q )		

Note) CQC compliant type are available. Ex ) AHES3190Q

## RATING

### Coil data

- Operating characteristics such as " Operate voltage " and " Release voltage " are influenced by mounting conditions or ambient temperature, etc.  
Therefore, please use the relay within  $\pm 5\%$  of rated coil voltage.
- " Initial " means the condition of products at the time of delivery.

Rated coil voltage	Operate voltage*1 ( at 20 °C )	Release voltage*1 ( at 20 °C )	Rated operating current ( $\pm 10\%$ , at 20 °C )	Coil resistance ( $\pm 10\%$ , at 20 °C )	Rated operating power	Max. allowable voltage ( at 55 °C )
6 V DC	Max. 75 % V of rated coil voltage ( Initial )	Min. 5 % V of rated coil voltage ( Initial )	313 mA	19.1 $\Omega$	1,880 mW Holding*2: 170 mW*3	110 % V of rated coil voltage 150 % V of rated coil voltage*4
9 V DC			209 mA	43.1 $\Omega$		
12 V DC			157 mA	76.6 $\Omega$		
24 V DC			78 mA	306.4 $\Omega$		
48 V DC			39 mA	1,225.5 $\Omega$		

\*1: Square, pulse drive

\*2: When using with the holding voltage, switch to the holding voltage after 100 ms from the application of the coil rated voltage.

\*3: With 30 % V coil holding voltage

\*4: Total application time: Max. 24 hours

# Power Relays ( Over 2 A ) HE-S RELAYS

## Specifications

Item		Specifications	
Contact data	Contact arrangement		2 Form A ( 2a ), 2 Form A 1 Form B ( 2a1b )
	Form A contact	Contact resistance ( initial )	Max. 100 mΩ ( by voltage drop 6 V DC 1 A ), Max. 3 mΩ ( by voltage drop 6 V DC 40 A, reference value )
		Contact material	AgSnO <sub>2</sub> type
	Form B contact* <sup>6</sup>	Contact resistance ( initial )	Max. 100 mΩ ( by voltage drop 1 A 6 V DC )
		Contact material	Au flashed AgNi type
	Form A contact	Contact rating ( resistive )	40 A 277 V AC, 5 A 110 V DC
		Max. switching power ( resistive )	11,080 VA, 550 W
		Max. switching voltage	480 V AC, 110 V DC
		Max. switching current	40 A
		Min. switching load ( reference value ) * <sup>1</sup>	100 mA 5 V DC
	Form B contact* <sup>6</sup>	Contact rating ( resistive )	1 A 277 V AC, 1 A 30 V DC
		Max. switching power ( resistive )	277 VA, 30 W
		Max. switching voltage	277 V AC, 30 V DC
		Max. switching current	1 A
		Min. switching load ( reference value ) * <sup>1</sup>	10 mA 5 V DC
Insulation resistance ( initial )		Min. 1,000 MΩ ( at 500 V DC, Measured portion is the same as the case of dielectric strength )	
Short current ( Form A contact, initial )		Max. 1,000 A 1 ms, 3 times ( reference value )	
Dielectric strength ( initial )	Between open Form A contacts	2,000 V rms for 1 min ( detection current: 10 mA )	
	Between Form A contact and coil	5,000 V rms for 1 min ( detection current: 10 mA )	
	Between Form A contact sets	5,000 V rms for 1 min ( detection current: 10 mA )	
	Between open Form B contacts* <sup>6</sup>	1,000 V rms for 1 min ( detection current: 10 mA )	
	Between Form B contact and coil* <sup>6</sup>	2,000 V rms for 1 min ( detection current: 10 mA )	
Surge withstand voltage ( initial ) * <sup>2</sup>	Between contact and coil	10,000 V ( Between Form A contact and coil ), 2,500 V ( Between Form B contact and coil )	
	Coil holding voltage* <sup>3</sup>		30 to 110 % V ( at -40 to +55 °C ) 30 to 60 % V ( at +55 to +85 °C )
Time characteristics ( initial )	Operate time	Max. 30 ms ( at rated coil voltage, at 20 °C, without bounce )	
	Release time* <sup>4</sup>	Max. 10 ms ( at rated coil voltage, at 20 °C, without bounce, without diode )	
Shock resistance	Functional	98 m/s <sup>2</sup> ( half-sine shock pulse: 11 ms, detection time: 10 μs )	
	Destructive	980 m/s <sup>2</sup> ( half-sine shock pulse: 6 ms )	
Vibration resistance	Functional	10 to 55 Hz ( at double amplitude of 1 mm, detection time: 10 μs )	
	Destructive	10 to 55 Hz ( at double amplitude of 1.5 mm )	
Expected life	Mechanical life	Min. 5 × 10 <sup>6</sup> ope. ( at 180 times/min )	
Conditions	Conditions for usage, transport and storage* <sup>5</sup>	Ambient temperature: -40 to 70 °C ( Max. carrying current 40 A ) -40 to 85 °C ( Max. carrying current 35 A, transport and storage ) Humidity: 5 to 85 % RH ( Avoid icing and condensation )	
Unit weight		Approx. 64 g	

\*1: This value can change due to the switching frequency, environmental conditions, and desired reliability level, therefore it is recommended to check this with the actual load.

\*2: Wave is standard shock voltage of ±1.2 × 50 μs according to JEC-212-1981

\*3: Coil holding voltage is the coil voltage after 100 ms from the applied rated coil voltage.

\*4: Release time will lengthen if a diode, etc., is connected in parallel to the coil. Be sure to verify operation under actual conditions.

\*5: When using at 55 °C or higher, the coil holding voltage should be 30 to 60 % V. And for ambient temperature, please read " GUIDELINES FOR RELAY USAGE ".

\*6: Regarding Form B contact, only the 2 Form A 1 Form B ( 2a1b ) type applies.

# Power Relays ( Over 2 A ) HE-S RELAYS

## Expected electrical life

Form B contact specification is only applicable to 2 Form A 1 Form B ( 2a1b ) type

### Standard type

Type	Load	Switching capacity	Number of operations
Form A contact	Resistive load	20 A 277 V AC	100 × 10 <sup>3</sup> ope. ( ON : OFF = 1 s : 9s )
		35 A 277 V AC	30 × 10 <sup>3</sup> ope. ( ON : OFF = 1 s : 9s )
		40 A 277 V AC	10 <sup>3</sup> ope. ( ON : OFF = 1 s : 9s )
		5 A 110 V DC	10 × 10 <sup>3</sup> ope. ( ON : OFF = 1 s : 9s )
Form B contact	Resistive load	35 A 250 V AC ( cos φ = 0.8 )	30 × 10 <sup>3</sup> ope. ( ON : OFF = 0.1s : 10s )
		1 A 277 V AC	100 × 10 <sup>3</sup> ope. ( ON : OFF = 1 s : 9s )
		1 A 30 V DC	100 × 10 <sup>3</sup> ope. ( ON : OFF = 1 s : 9s )

### Long life type

Type	Load	Switching capacity	Number of operations
Form A contact	Resistive load	20 A 277 V AC	200 × 10 <sup>3</sup> ope. ( ON : OFF = 1 s : 9s )
		30 A 220 V AC	100 × 10 <sup>3</sup> ope. ( ON : OFF = 1 s : 9s )
		35 A 277 V AC	50 × 10 <sup>3</sup> ope. ( ON : OFF = 1 s : 9s )
		40 A 277 V AC	10 <sup>3</sup> ope. ( ON : OFF = 1 s : 9s )
		5 A 110 V DC	10 × 10 <sup>3</sup> ope. ( ON : OFF = 1 s : 9s )
Form B contact	Resistive load	35 A 250 V AC ( cos φ = 0.8 )	50 × 10 <sup>3</sup> ope. ( ON : OFF = 0.1s : 10s )
		1 A 277 V AC	100 × 10 <sup>3</sup> ope. ( ON : OFF = 1 s : 9s )
		1 A 30 V DC	100 × 10 <sup>3</sup> ope. ( ON : OFF = 1 s : 9s )

## REFERENCE DATA

### 1. Max. switching capacity

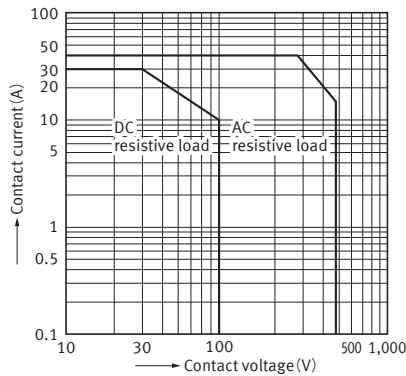

### 2. Switching life curve

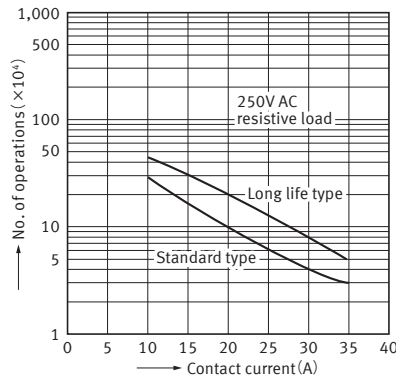

### 3. Coil temperature characteristics

Measured portion : Coil inside  
Contact current : 35A, 0A  
Ambient temperature : 25°C, 85°C

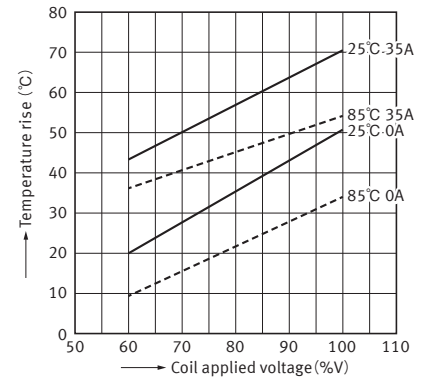

### 4. Ambient temperature characteristics (Average)

Tested sample : AHES3191, 6 pcs.

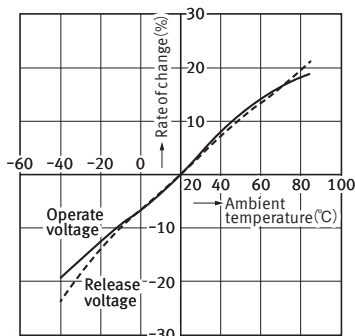

### 5-1. Contact resistance ( 6 V DC, 20 A )

Tested sample : AHES4291, 20pcs.  
Conditions : 6 V DC, 20 A

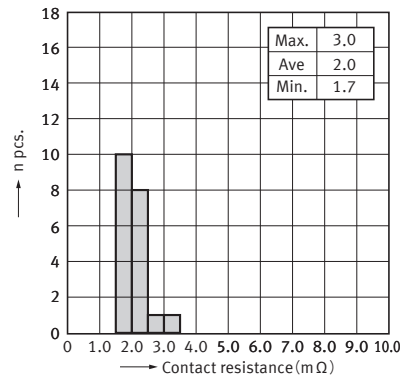

### 5-2. Contact resistance ( 6 V DC, 40 A )

Tested sample : AHES4291, 20pcs.  
Conditions : 6 V DC, 40 A

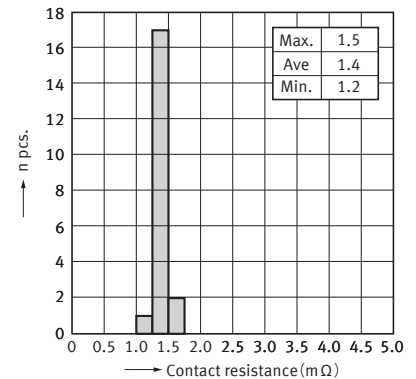

# Power Relays ( Over 2 A ) HE-S RELAYS

## DIMENSIONS ( Unit: mm )

**CAD** The CAD data of the products with a " CAD " mark can be downloaded from our Website.

### 2 Form A ( 2a )

**CAD**



External dimensions

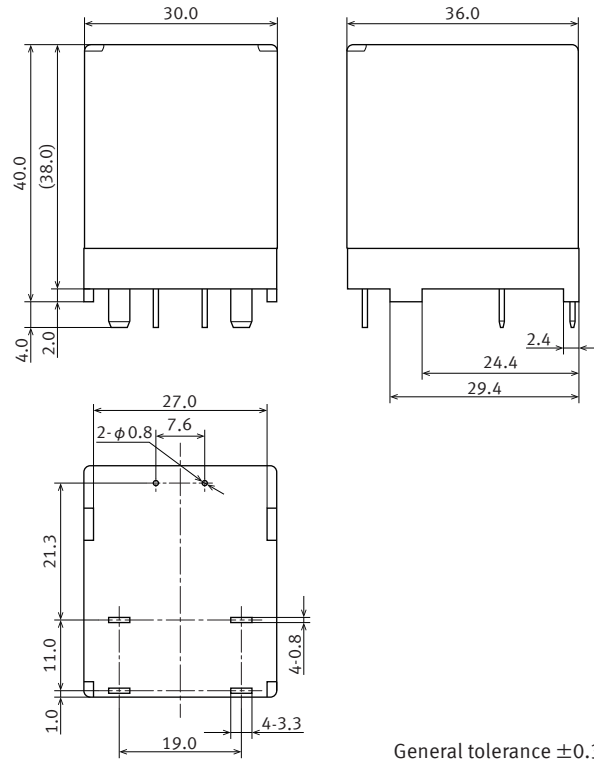

General tolerance  $\pm 0.3$

Note: Terminal dimensions are values without pre-soldering thickness.

Recommended PC board pattern ( BOTTOM VIEW )

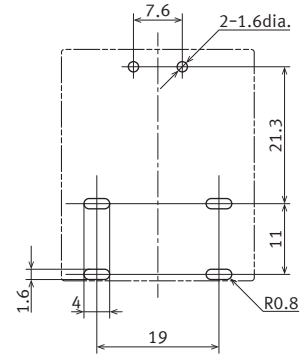

Tolerance  $\pm 0.1$

Schematic ( BOTTOM VIEW )

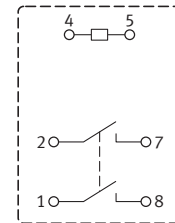

### 2 Form A 1 Form B ( 2a1b )

**CAD**



External dimensions

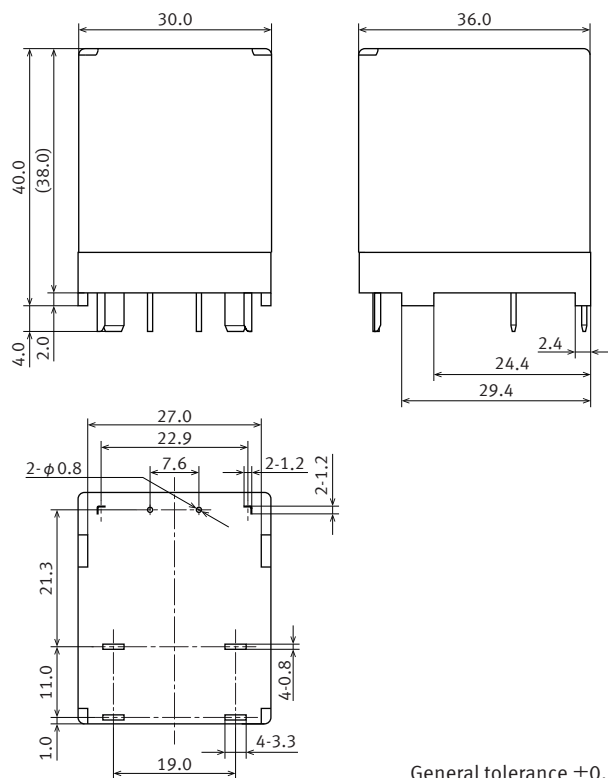

General tolerance  $\pm 0.3$

Note: Terminal dimensions are values without pre-soldering thickness.

Recommended PC board pattern ( BOTTOM VIEW )

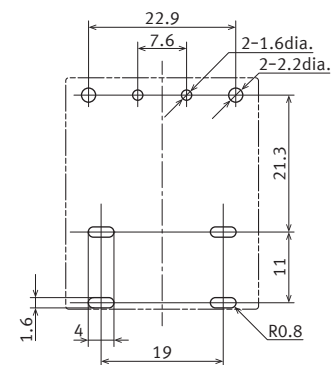

Tolerance  $\pm 0.1$

Schematic ( BOTTOM VIEW )

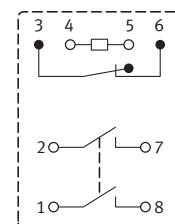

# Power Relays ( Over 2 A ) HE-S RELAYS

## SAFETY STANDARDS

Each standard may be updated at any time, so please check our Website for the latest information.

### UL/C-UL ( Approved )

#### ● Standard type

2 Form A ( 2a ), 2 Form A 1 Form B ( 2a1b ) ( Form A contact )

File No.	Contact rating	Operations	Ambient temperature
E43149	35 A 277 V AC resistive	30 × 10 <sup>3</sup>	85 °C
	20 A 277 V AC resistive	100 × 10 <sup>3</sup>	85 °C
	15 A 480 V AC resistive	100 × 10 <sup>3</sup>	85 °C

2 Form A 1 Form B ( 2a1b ) ( Form A contact )

File No.	Contact rating	Operations	Ambient temperature
E43149	Make/Break 35 A , Rated 45 A 277 V AC Resistive	6 × 10 <sup>3</sup>	85 °C

2 Form A 1 Form B ( 2a1b ) ( Form B contact )

File No.	Contact rating	Operations	Ambient temperature
E43149	1 A 277 V AC resistive	100 × 10 <sup>3</sup>	85 °C
	1 A 30 V DC resistive	100 × 10 <sup>3</sup>	85 °C

### CSA ( Approved )

CSA standard certified by C-UL

### VDE ( Approved )

#### ● Standard type and Long life type ( Common )

2 Form A ( 2a ), 2 Form A 1 Form B ( 2a1b ) ( Form A contact )

File No.	Contact rating	Operations	Ambient temperature
40042442	AC-3 480 V AC 8 A $\cos\phi = 0.65$	30 × 10 <sup>3</sup>	85 °C
	AC-3 230 V AC 12 A $\cos\phi = 0.65$	30 × 10 <sup>3</sup>	
	250 V AC 20 A $\cos\phi = 1$	80 × 10 <sup>3</sup>	
	AC-7a 263 V AC 35 A $\cos\phi = 0.8$	30 × 10 <sup>3</sup>	
	AC-7a 263 V AC 52.5 A $\cos\phi = 0.8$	50	

2 Form A 1 Form B ( 2a1b ) ( Form B contact )

File No.	Contact rating	Operations	Ambient temperature
40042442	DC-13 24 V DC 1 A, L/R = 48 ms	80 × 10 <sup>3</sup>	85 °C
	30 V DC 1 A 0 ms	80 × 10 <sup>3</sup>	

### TV rating

#### ● Standard type

2 Form A ( 2a ), 2 Form A 1 Form B ( 2a1b ) ( Form A contact )

File No.	Rating
E43149	TV-8

### CQC ( Applied only to the product number with " Q " at the end. )

#### ● Standard type

2 Form A ( 2a ), 2 Form A 1 Form B ( 2a1b ) ( Form A contact )

File No.	Contact rating	Operations	Ambient temperature
CQC20002260136	40 A 277 V AC	10 × 10 <sup>3</sup>	-40 to +20 °C

2 Form A 1 Form B ( 2a1b ) ( Form B contact )

File No.	Contact rating	Operations	Ambient temperature
CQC20002260136	1 A 277 V AC	10 × 10 <sup>3</sup>	-40 to +20 °C
CQC20002260136	1 A 30 V DC	10 × 10 <sup>3</sup>	-40 to +20 °C

#### ● Long life type

2 Form A ( 2a ), 2 Form A 1 Form B ( 2a1b ) ( Form A contact )

File No.	Contact rating	Operations	Ambient temperature
E43149	35 A 277 V AC resistive	50 × 10 <sup>3</sup>	85 °C
	20 A 277 V AC resistive	200 × 10 <sup>3</sup>	85 °C
	15 A 480 V AC resistive	100 × 10 <sup>3</sup>	85 °C

2 Form A 1 Form B ( 2a1b ) ( Form A contact )

File No.	Contact rating	Operations	Ambient temperature
E43149	Make/Break 35 A , Rated 45 A 277 V AC Resistive	6 × 10 <sup>3</sup>	85 °C

2 Form A 1 Form B ( 2a1b ) ( Form B contact )

File No.	Contact rating	Operations	Ambient temperature
E43149	1 A 277 V AC resistive	100 × 10 <sup>3</sup>	85 °C
	1 A 30 V DC resistive	100 × 10 <sup>3</sup>	85 °C

#### ● Long life type

2 Form A ( 2a ), 2 Form A 1 Form B ( 2a1b ) ( Form A contact )

File No.	Rating
E43149	TV-10

#### ● Long life type

2 Form A ( 2a ), 2 Form A 1 Form B ( 2a1b ) ( Form A contact )

File No.	Contact rating	Operations	Ambient temperature
CQC20002260136	40 A 277 V AC	15 × 10 <sup>3</sup>	-40 to +70 °C

2 Form A 1 Form B ( 2a1b ) ( Form B contact )

File No.	Contact rating	Operations	Ambient temperature
CQC20002260136	1 A 277 V AC	15 × 10 <sup>3</sup>	-40 to +70 °C
CQC20002260136	1 A 30 V DC	15 × 10 <sup>3</sup>	-40 to +70 °C

# Power Relays ( Over 2 A ) HE-S RELAYS

## INSULATION CHARACTERISTICS ( IEC61810-1 )

Item	Characteristics
Clearance/Creepage distance ( IEC61810-1 )	Min. 5.5/8.0 mm ( Form A contact )
Category of protection ( IEC61810-1 )	RT II
Tracking resistance ( IEC60112 )	PTI 175
Insulation material group	III a
Over voltage category	III
Rated voltage	250 V
Pollution degree	3
Type of insulation ( Between contact and coil )	Reinforced insulation
Type of insulation ( Between open contact )	Full disconnection

Note(s): Actual value.

## GUIDELINES FOR USAGE

■ For cautions for use, please read " GUIDELINES FOR RELAY USAGE ".  
[https://industry.panasonic.com/global/en/products/control/relay/cautions\\_use](https://industry.panasonic.com/global/en/products/control/relay/cautions_use)

### ■ Guidelines for HE-S relays usage

- When coil holding voltage controlled by PWM, check coil holding voltage and operation of relay under the actual condition.
- If this relay is used as a high voltage direct current switch, it may lose the ability to provide a proper cut-off in the final breakdown mode.  
 In the event that the relay loses cut-off ability, there is a possibility that burning may spread to surrounding parts, so configure the layout so that the power is turned off within one second and from the point of view of safety, consider installing a failsafe circuit in the device.  
 Varistor is recommended for the purpose of coil surge absorber.  
 Diode connection for the absorber makes contact operation slower and cannot assure the proper cut off.  
 < Recommended Varistor >  
 Withstanding energy: Min. 1 J  
 Varistor voltage: Min. 150 % of rated voltage  
 If you are using an inductive load ( L load ) such that  $L/R > 1$  ms, add surge protection in parallel with the inductive load.
- To detect the main contacts welding by Form b contacts, please design the appropriate detection time considering with the release and bounce time. ( 2a1b type only )

### ● Conditions for usage, transport and storage

- 1) Ambient temperature
  - 40 to + 70 °C ( Max. carrying current 40 A )
  - 40 to + 85 °C ( Max. carrying current 35 A )
  - Note) When using at 55 °C or higher, the coil holding voltage should be 30 % V to 60 % V.
- 2) Humidity
  - 5 to 85 % RH ( Avoid icing and condensation )
  - Note) In addition the humidity range depends on temperature.  
 The allowable ranges are as shown in the figure.
- 3) Air pressure
  - 86 to 106 kPa

[ Allowable range of temperature and humidity for usage, transport and storage ]

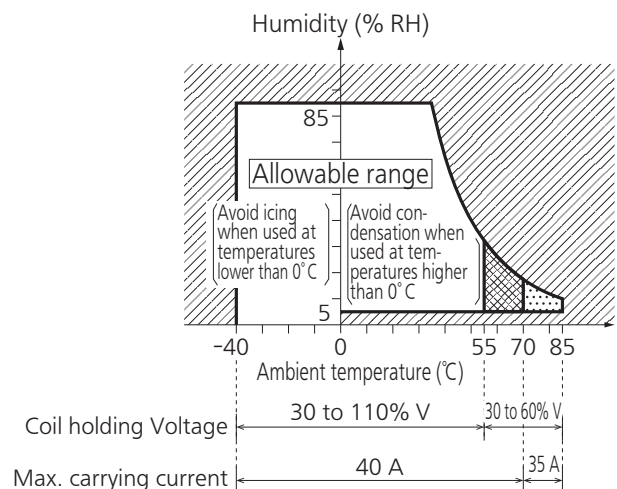

# Power Relays ( Over 2 A ) HE-S RELAYS

## ● Solder conditions

Please obey the following conditions.

### 1. Automatic soldering

#### (1) Preheating

Temperature	Max. 120 °C ( solder surface terminal portion )
Time	Within 120 s

#### (2) Soldering

Solder temperature	260 ±5 °C
Soldering time	Within 10 s

### 2. Manual soldering

Solder temperature	Max. 270 °C	Max. 350 °C
Soldering time	Within 10 s	Within 5 s

Notes) Effects of soldering heat on the relays vary depending on the PC board. So please confirm actual soldering condition with the PC board used for assembling.

- For cautions for use, please read " GUIDELINES FOR RELAY USAGE ".  
[https://industry.panasonic.com/global/en/products/control/relay/cautions\\_use](https://industry.panasonic.com/global/en/products/control/relay/cautions_use)

## Precautions for Coil Input

### ■ Long term current carrying

A circuit that will be carrying a current continuously for long periods without relay switching operation. ( circuits for emergency lamps, alarm devices and error inspection that, for example, revert only during malfunction and output warnings with form B contacts ) Continuous, long-term current to the coil will facilitate deterioration of coil insulation and characteristics due to heating of the coil itself. For circuits such as these, please use a magnetic-hold type latching relay. If you need to use a single stable relay, use a sealed type relay that is not easily affected by ambient conditions and make a failsafe circuit design that considers the possibility of contact failure or disconnection.

### ■ DC Coil operating power

Steady state DC current should be applied to the coil. The wave form should be rectangular. If it includes ripple, the ripple factor should be less than 5 %. However, please check with the actual circuit since the electrical characteristics may vary. The rated coil voltage should be applied to the coil and the set/reset pulse time of latching type relay differs for each relays, please refer to the relay's individual specifications.

### ■ Coil connection

When connecting coils of polarized relays, please check coil polarity ( + , - ) at the internal connection diagram ( Schematic ). If any wrong connection is made, it may cause unexpected malfunction, like abnormal heat, fire and so on, and circuit do not work. Avoid impressing voltages to the set coil and reset coil at the same time.

### ■ Maximum allowable voltage and temperature rise

Proper usage requires that the rated coil voltage be impressed on the coil. Note, however, that if a voltage greater than or equal to the maximum continuous voltage is impressed on the coil, the coil may burn or its layers short due to the temperature rise. Furthermore, do not exceed the usable ambient temperature range listed in the catalog.

### ● Operate voltage change due to coil temperature rise

In DC relays, after continuous passage of current in the coil, if the current is turned OFF, then immediately turned ON again, due to the temperature rise in the coil, the operate voltage will become somewhat higher. Also, it will be the same as using it in a higher temperature atmosphere. The resistance/temperature relationship for copper wire is about 0.4 % for 1 °C, and with this ratio the coil resistance increases. That is, in order to operate of the relay, it is necessary that the voltage be higher than the operate voltage and the operate voltage rises in accordance with the increase in the resistance value. However, for some polarized relays, this rate of change is considerably smaller.

## Ambient Environment

### Usage, Transport, and Storage Conditions

During usage, storage, or transportation, avoid locations subjected to direct sunlight and maintain normal temperature, humidity and pressure conditions.

#### Temperature/Humidity/Pressure

When transporting or storing relays while they are tube packaged, there are cases the temperature may differ from the allowable range. In this case be sure to check the individual specifications.

Also allowable humidity level is influenced by temperature, please check charts shown below and use relays within mentioned conditions. ( Allowable temperature values differ for each relays, please refer to the relay's individual specifications. )

##### 1) Temperature:

The tolerance temperature range differs for each relays, please refer to the relay's individual specifications

##### 2) Humidity: 5 to 85 % RH

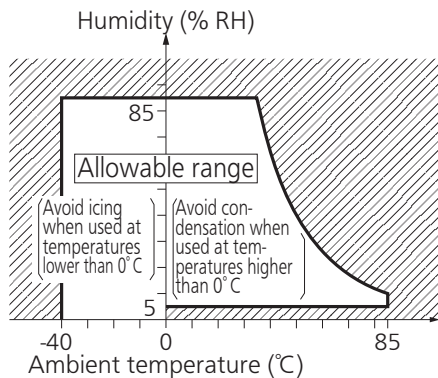

##### 3) Pressure: 86 to 106 kPa

#### Dew condensation

Condensation occurs when the ambient temperature drops suddenly from a high temperature and humidity, or the relay is suddenly transferred from a low ambient temperature to a high temperature and humidity.

Condensation causes the failures like insulation deterioration, wire disconnection and rust etc.

Panasonic Industry Co., Ltd. does not guarantee the failures caused by condensation.

The heat conduction by the equipment may accelerate the cooling of device itself, and the condensation may occur.

Please conduct product evaluations in the worst condition of the actual usage. ( Special attention should be paid when high temperature heating parts are close to the device. Also please consider the condensation may occur inside of the device. )

#### Icing

Condensation or other moisture may freeze on relays when the temperature become lower than 0 °C. This icing causes the sticking of movable portion, the operation delay and the contact conduction failure etc. Panasonic Industry Co., Ltd. does not guarantee the failures caused by the icing.

The heat conduction by the equipment may accelerate the cooling of relay itself and the icing may occur. Please conduct product evaluations in the worst condition of the actual usage.

#### Low temperature and low humidity

The plastic becomes brittle if the relay is exposed to a low temperature, low humidity environment for long periods of time.

#### High temperature and high humidity

Storage for extended periods of time ( including transportation periods ) at high temperature or high humidity levels or in atmospheres with organic gases or sulfide gases may cause a sulfide film or oxide film to form on the surfaces of the contacts and/or it may interfere with the functions. Check out the atmosphere in which the units are to be stored and transported.

#### Package

In terms of the packing format used, make every effort to keep the effects of moisture, organic gases and sulfide gases to the absolute minimum.

#### Silicon

When a source of silicone substances ( silicone rubber, silicone oil, silicone coating materials and silicone filling materials etc. ) is used around the relay, the silicone gas ( low molecular siloxane etc. ) may be produced.

This silicone gas may penetrate into the inside of the relay. When the relay is kept and used in this condition, silicone compound may adhere to the relay contacts which may cause the contact failure. Do not use any sources of silicone gas around the relay ( Including plastic sealed types ).

#### NOx Generation

When relay is used in an atmosphere high in humidity to switch a load which easily produces an arc, the NOx created by the arc and the water absorbed from outside the relay combine to produce nitric acid.

This corrodes the internal metal parts and adversely affects operation.

Avoid use at an ambient humidity of 85 % RH or higher ( at 20 °C ). If use at high humidity is unavoidable, please contact our sales representative.

## Others

### ■ Cleaning

- Although the environmentally sealed type relay ( plastic sealed type, etc. ) can be cleaned, avoid immersing the relay into cold liquid ( such as cleaning solvent ) immediately after soldering. Doing so may deteriorate the sealing performance.
- Cleaning with the boiling method is recommended ( The temperature of cleaning liquid should be 40 °C or lower ). Avoid ultrasonic cleaning on relays. Use of ultrasonic cleaning may cause breaks in the coil or slight sticking of the contacts due to ultrasonic energy.

Please refer to " **the latest product specifications** " when designing your product.

- Requests to customers:

<https://industry.panasonic.com/global/en/salespolicies>

■ Global Sales Network Information: [industry.panasonic.com/global/en/salesnetwork/globalnetwork](https://industry.panasonic.com/global/en/salesnetwork/globalnetwork)

---

**Panasonic**  
INDUSTRY

**Panasonic Industry Co., Ltd.**

Electromechanical Control Business Division

■ 1006, Oaza Kadoma, Kadoma-shi, Osaka 571-8506, Japan  
[industry.panasonic.com](https://industry.panasonic.com)