



HESTORE.HU

elektronikai alkatrész áruház

EN: This Datasheet is presented by the manufacturer.

Please visit our website for pricing and availability at www.hestore.hu.



mikromedia™

for STM32®

Compact multimedia development system rich with on-board peripherals for all-round development on **STM32F207VGT6** and **STM32F407VGT6** devices



TO OUR VALUED CUSTOMERS

I want to express my thanks to you for being interested in our products and for having confidence in MikroElektronika.

The primary aim of our company is to design and produce high quality electronic products and to constantly improve the performance thereof in order to better suit your needs.

A white, handwritten signature in cursive script, appearing to read 'N. Matic', set against a dark green background.

Nebojsa Matic
General Manager

Table of Contents

Introduction to mikromedia for STM32®	4	Programming with mikroProg™ programmer	18
Package contains	5	mikroProg Suite™ for ARM® software	19
Key features	6	Programming with ST-LINK V2 programmer	20
System specifications	7	4. Reset button	22
1. Power supply	8	5. Oscillators	24
USB power supply	8	6. MicroSD card slot	26
Battery power supply	8	7. Touch screen	28
2. Key microcontrollers features	10	8. Audio module	30
STM32F207VGT6	10	9. USB connection	32
STM32F407VGT6	11	10. Accelerometer	34
3. Programming the microcontroller	12	11. Flash memory	36
Programming with mikroBootloader	14	12. Pads	38
step 1 - Connecting mikromedia	14	13. Pinout	39
step 2 - Browsing for .hex file	15	14. Dimensions	40
step 3 - Selecting .hex file	15	15. Mikromedia accessories	41
step 4 - Uploading .hex file	16	16. What's next	42
step 5 - Finish upload	17		

Introduction to mikromedia for STM32®

mikromedia for STM32® is a compact development system with lots of on-board peripherals which allow development of devices with multimedia contents. The central part of the system is a 32-bit **STM32F207VGT6** or **STM32F407VGT6** microcontroller. mikromedia for STM32® features integrated modules such as stereo MP3 codec, **TFT 320x240** touch screen display, accelerometer, USB connector, MMC/SD card slot, 8 Mbit flash memory, 2x26 connection pads and other. It comes pre-programmed with USB bootloader, but can also be programmed with external programmers, such as mikroProg™ for STM32® or ST-LINK. Mikromedia is compact and slim, and perfectly fits in the palm of the hand, which makes it convenient platform for mobile devices.



Package contains



01 Damage resistant protective box

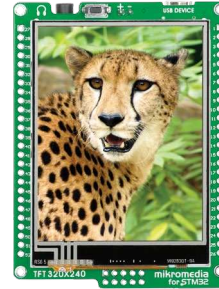

02 mikromedia for STM32® development system



03 User's guide, schematic and pinout



04 USB cable, headers and ST-LINK V2 to mikroProg™ adapter

Key features

- 01 RESET button
- 02 Connection Pads
- 03 TFT 320x240 display
- 04 USB MINI-B connector
- 05 Charge indication LED
- 06 LI-Polymer battery connector
- 07 3.5mm headphone connector
- 08 Power supply regulator
- 09 Crystal oscillator
- 10 VS1053 Stereo mp3 coder/decoder
- 11 STM32F207VGT6 or STM32F407VGT6 microcontroller
- 12 Accelerometer
- 13 Serial flash memory
- 14 microSD card slot
- 15 Power indication LED
- 16 JTAG/SWD programmer connector

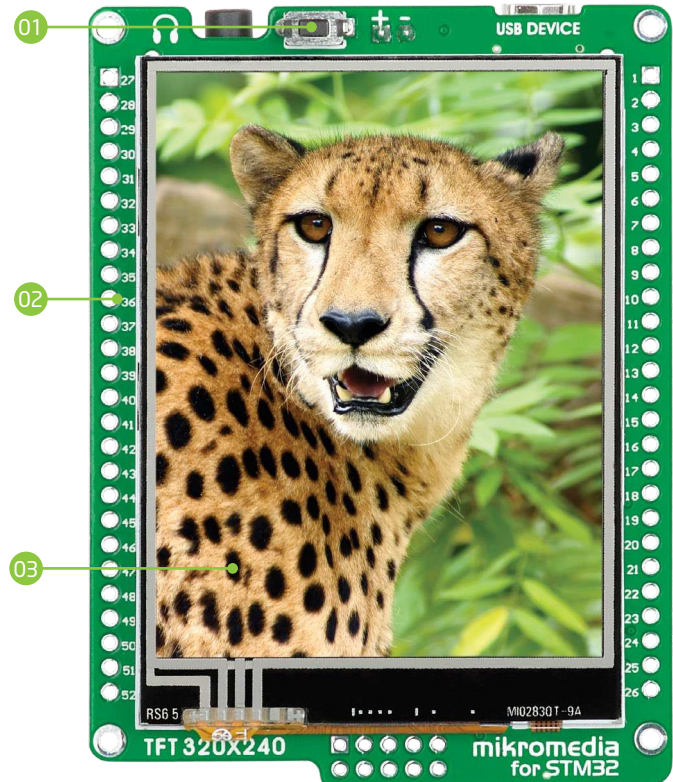

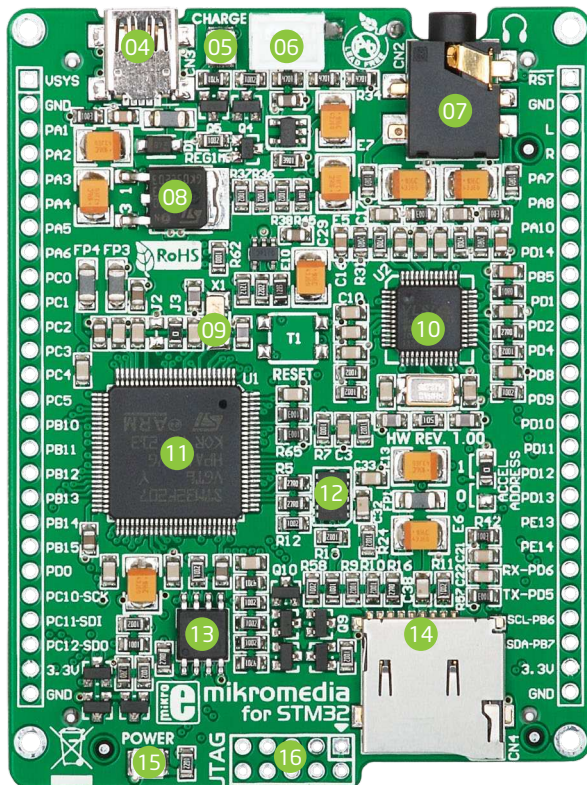

System specification



power supply

Via USB cable (5V DC)



power consumption

46.5 mA with erased MCU
(when on-board modules are inactive)



board dimensions

81.2 x 60.5 mm (3.19 x 2.38 inch)



weight

~45 g (0.10 lbs)



class B product

Product complies with the Class B limit of EN 55022 and can be used in the domestic, residential, commercial and industrial environments.



CAUTION: Electrostatic sensitive device

Permanent damage may occur on devices subjected to high energy electrostatic discharges which readily accumulate on the human body or test equipment and can discharge without detection.

1. Power supply

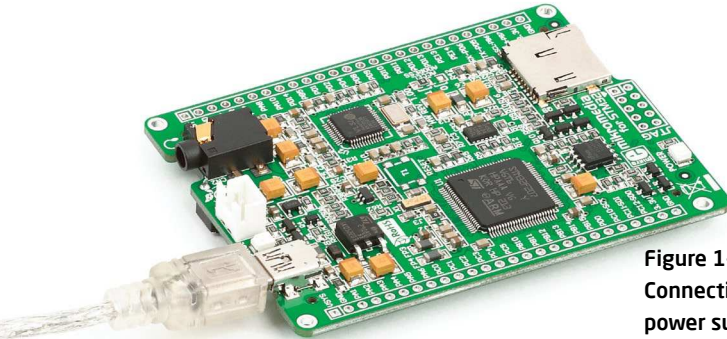

Figure 1-1:
Connecting USB
power supply

USB power supply

You can apply power supply to the board using **Mini-B USB** cable provided with the board. On-board voltage regulators provide the appropriate voltage levels to each component on the board. **Power LED (GREEN)** will indicate the presence of power supply.

Battery power supply

You can also power the board using a **Li-Polymer** battery, via on-board battery connector. On-board battery charger circuit **MCP73832** enables you to charge the battery over a USB connection. **LED diode (RED)** will indicate when the battery is charging. Charging current is ~250mA and charging voltage is 4.2V DC.

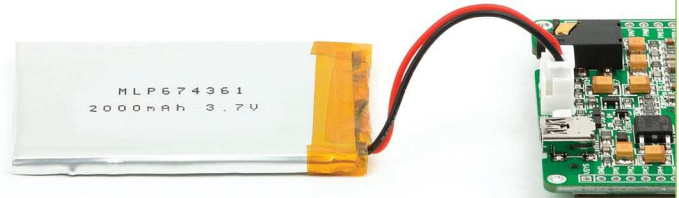

Figure 1-2: Connecting Li-Polymer battery

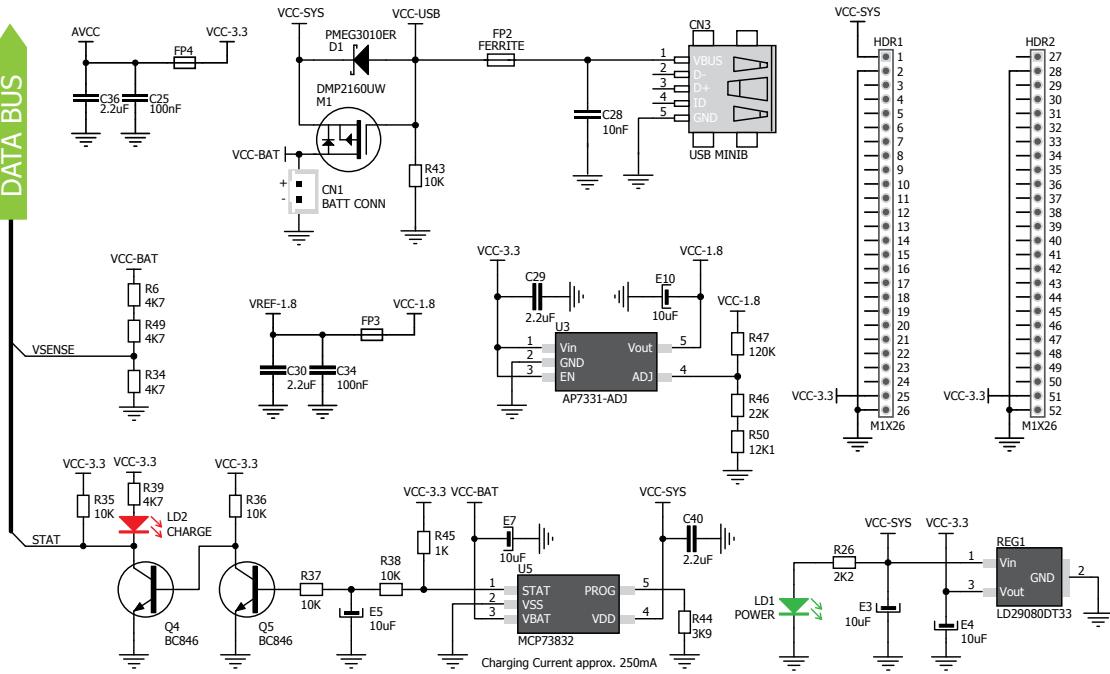

Figure 1-3: Power supply schematic

2. Key microcontrollers features

The mikromedia for STM32[®] M3 development system comes with the **STM32F207VGT6** microcontroller. This high-performance **32-bit** microcontroller with its integrated modules and in combination with other on-board modules is ideal for multimedia applications.

STM32F207VGT6

- 1.25 DMIPS/MHz, 32-bit Cortex™-M3 Core;
- 1 Mbyte Flash memory;
- 128 + 4 Kbytes of SRAM;
- 83 I/O pins;
- SPI, I²C, CAN, USB, Ethernet;
- USART, UART;
- 16-bit and 32-bit Timers, up to 120MHz;
- Internal Oscillator 16MHz, 32kHz, PLL;
- ADC, DAC, etc.

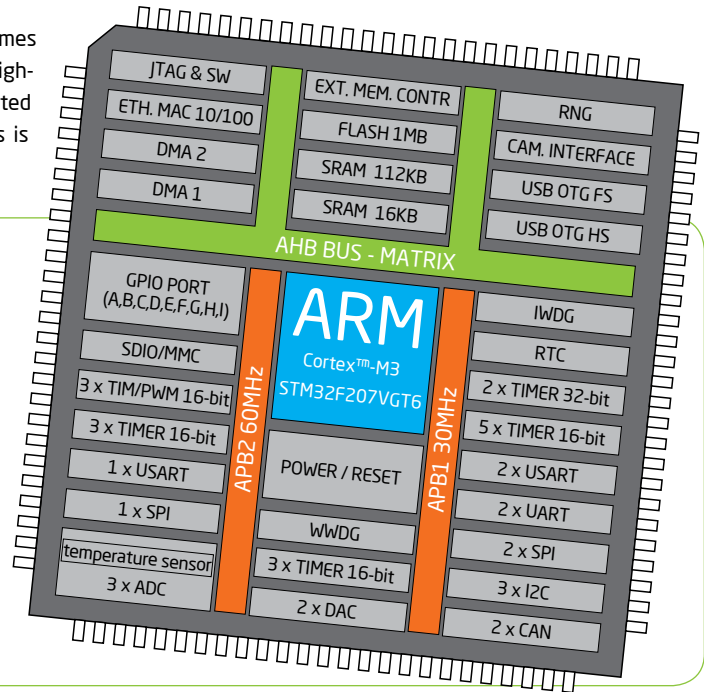

The mikromedia for STM32® M4 development system comes with the **STM32F407VGT6** microcontroller, which can deliver even more processing power. With up to 168MHz operation, this **32-bit** microcontroller with other on-board modules is a perfect choice for performance-demanding applications.

STM32F407VGT6

- 1.25 DMIPS/MHz, 32-bit Cortex™-M4 Core;
- 1 MB flash memory;
- 192 + 4 KB of SRAM;
- 83 I/O pins;
- SPI, I²C, CAN, USB, Ethernet;
- USART, UART;
- 16-bit and 32-bit Timers, up to 168MHz;
- Internal Oscillator 16MHz, 32kHz, PLL;
- ADC, DAC, etc.

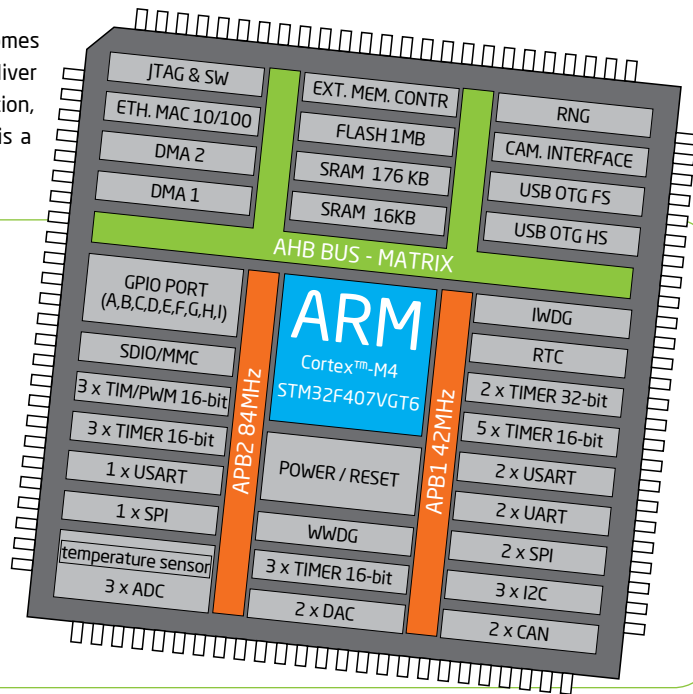

3. Programming the microcontroller

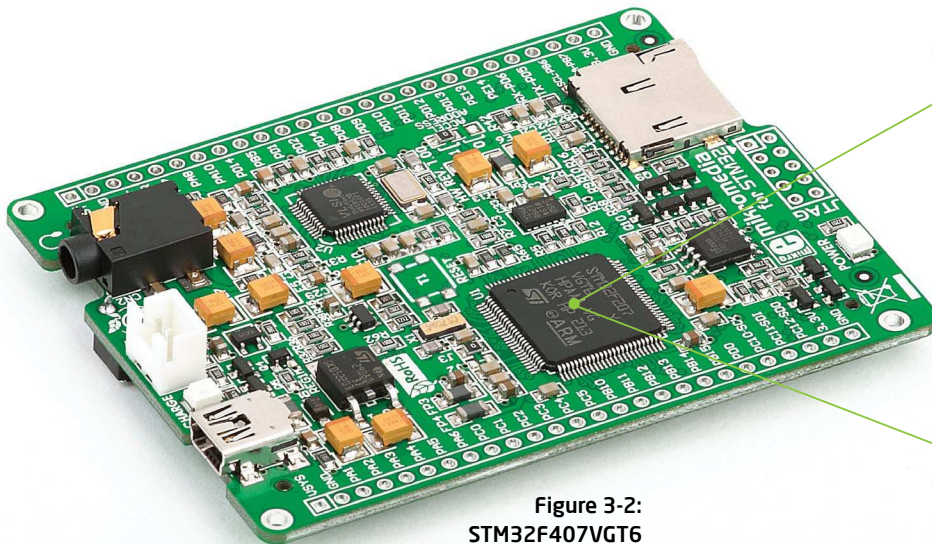

Figure 3-2:
STM32F407VGT6
Microcontroller



Figure 3-1:
STM32F207VGT6
Microcontroller



The microcontroller can be programmed in three ways:



The mikromedia for STM32® development system can be programmed in three different ways. **01** Using the bootloader which is preprogrammed into the device by default or via external programmers (**02** mikroProg™ or **03** ST-LINK V2™).

Programming with mikroBootloader

You can program the microcontroller with bootloader which is preprogrammed into the device by default. To transfer .hex file from a PC to MCU you need bootloader software (**mikroBootloader USB HID**) which can be downloaded from:



www.mikroe.com/downloads/get/1849/mikrobootloader_mikromedia_stm32_v210b.zip

Upon download, unzip it to desired location and start the mikroBootloader application:

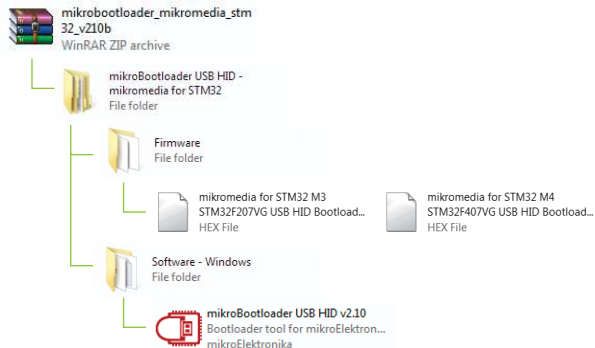

step 1 - Connecting mikromedia



Figure 3-3: USB HID mikroBootloader window

- 01 To start, connect the USB cable, or if already connected press the **Reset** button on your mikromedia board. Click the **Connect** button within 5s to enter the bootloader mode, otherwise existing microcontroller program will execute.

step 2 - Browsing for .HEX file



Figure 3-4: Browse for HEX

- 01 Click the **Browse for HEX** button and from a pop-up window (Figure 3.5) choose the .HEX file which will be uploaded to MCU memory.

step 3 - Selecting .HEX file

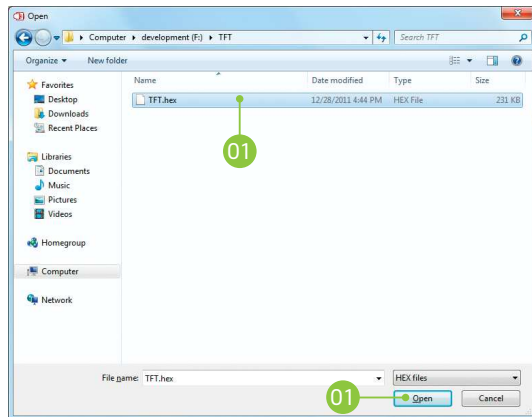

Figure 3-5: Selecting HEX

- 01 Select .HEX file using open dialog window.
- 02 Click **Open**.

step 4 - Uploading .HEX file



Figure 3-6: Begin uploading

- 01 To start .HEX file bootloading click the **Begin uploading** button.



Figure 3-7: Progress bar

- 01 Progress bar enables you to monitor .HEX file uploading.

step 5 - Finish upload



Figure 3-8: Restarting MCU

- 01 Click **OK** after uploading is finished and wait for 5 seconds. Board will automatically reset and your new program will execute.



Figure 3-9: mikroBootloader ready for next job

Programming with mikroProg™ programmer

The microcontroller can be programmed with external **mikroProg™ for STM32® programmer** and **mikroProg Suite™ for ARM®** software. The mikroProg™ programmer is connected to the development system via the CN5 (JTAG) connector. You can choose between two ways to program microcontrollers , **Figure 3-14**:

- 01 Via JTAG interface
- 02 Via Serial wire debug (SWD) interface



Figure 3-10:
Connecting
mikroProg™ to
mikromedia™

mikroProg™ is a fast USB 2.0 programmer with mikroCD™ hardware In-Circuit Debugger. It supports over 180 ARM® Cortex™ M3 and Cortex™ M4 microcontrollers from STM32® family. Outstanding performance, easy operation and elegant design are its key features.

NOTE: Before attaching the programming connector, you have to solder the provided 2x5 male header to the JTAG pads (CN5)

mikroProg Suite™ for ARM® software

On-board mikroProg™ programmer requires special programming software called mikroProg Suite™ for ARM®. This software is used for programming of all supported microcontroller families with ARM® Cortex™-M3 and Cortex™-M4 cores. The software has an intuitive interface and SingleClick™ programming technology. To begin, first locate the installation archive on the link below:



http://www.mikroe.com/downloads/get/1809/mikroprog_suite_for_arm.zip

After downloading, extract the package and double click the executable setup file, to start installation.

Quick guide

- 01 Click the **Detect MCU** button in order to recognize the device ID.
- 02 Click the **Read** button to read the entire microcontroller memory. You can click the **Save** button to save it to the target HEX file.
- 03 If you want to write the HEX file into the microcontroller, first make sure to load the target HEX file using the **Load** button. Then click the **Write** button to begin programming.
- 04 Click the **Erase** button to clear the microcontroller memory.

Figure 3-11:
mikroProg Suite™
for ARM® window



Programming with ST-LINK V2 programmer

The microcontroller can also be programmed with the **ST-LINK V2 programmer** and **mikroProg Suite™ for ARM®** software, **Figure 3-11**. This programmer connects with mikromedia board via **mikroProg to ST-LINK V2 adapter**.

In order to adjust the ST-LINK™ V2 programmer to be connected to the development system, it is necessary to provide the appropriate adapter such as the **mikroProg to ST-LINK V2 adapter**. 2x5 male headers should be first soldered on the CN5 connector pads. Then you should plug the adapter into the ST-LINK V2 programmer (2x10 header), and plug an IDC10 flat cable in headers, **Figure 3-13**

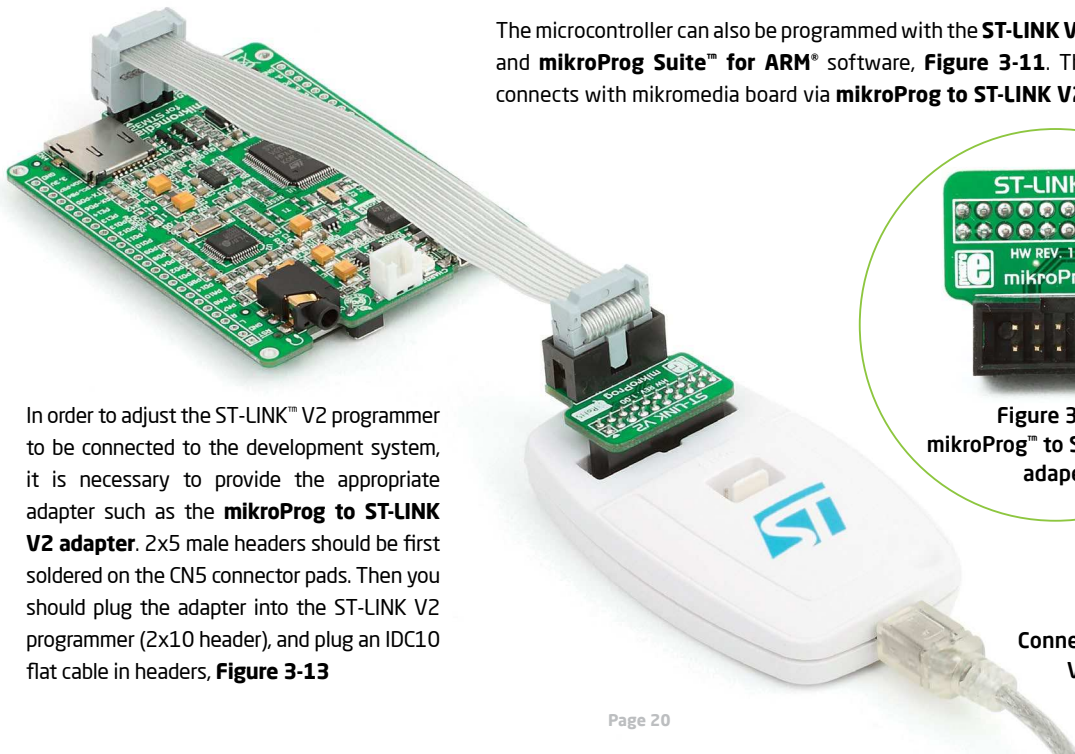

Figure 3-12:
mikroProg™ to ST-LINK™ V2
adaper

Figure 3-13:
Connecting ST-LINK™
V2 programmer

4. Reset button

Board is equipped with a reset button, which is located at the top of the front side (**Figure 4-2**). If you want to reset the circuit, press the reset button. It will generate a low voltage level on microcontroller reset pin (input). In addition, a reset can be externally provided through **pin 27** on side headers (**Figure 4-3**).



NOTE You can also solder additional reset button on the appropriate place at the back side of the board, **Figure 4-1**.

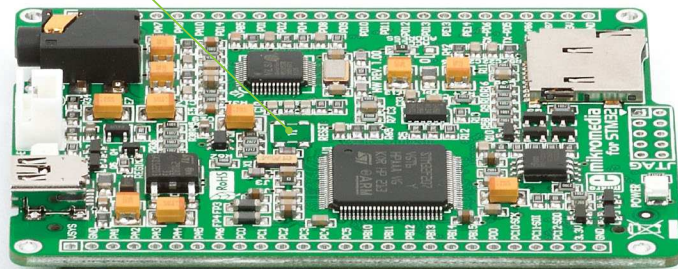

Figure 4-1: Location of additional reset button

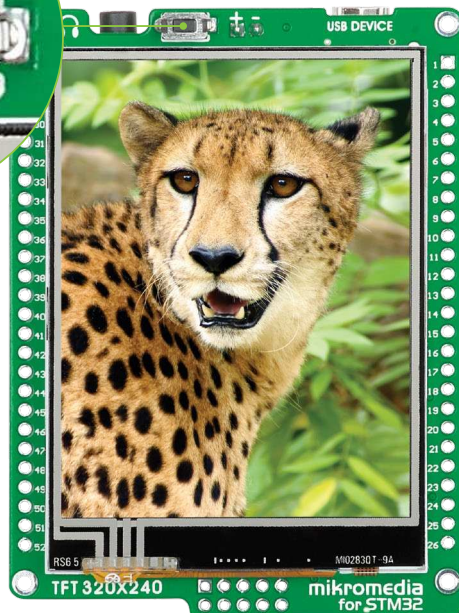
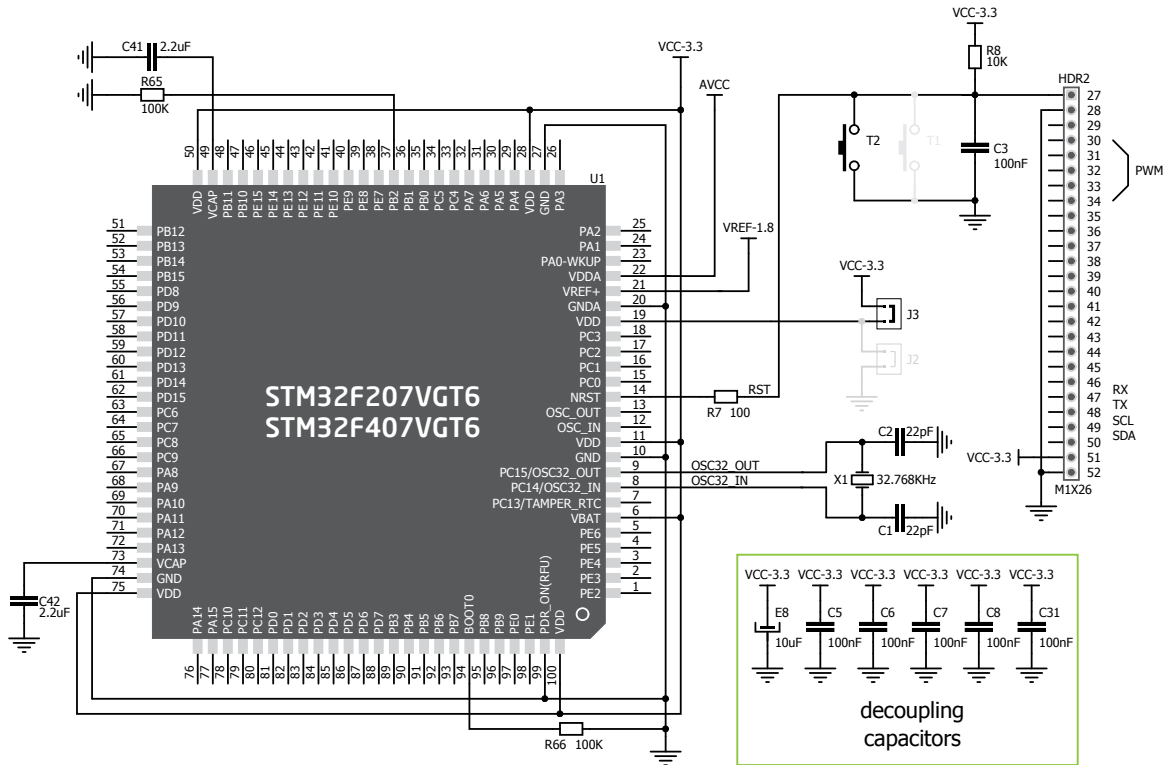

Figure 4-2: Frontal reset button



5. Oscillators

STM32F207VGT6 and **STM32F407VGT6** microcontrollers are equipped with an internal **16MHz RC oscillator** that provides a stable clock signal. Since the chips have an integrated PLL, this base frequency is suitable for further clock multiplication. Board also contains a **32.768kHz Crystal oscillator (X1)** which provides an external clock for internal **RTCC** module.

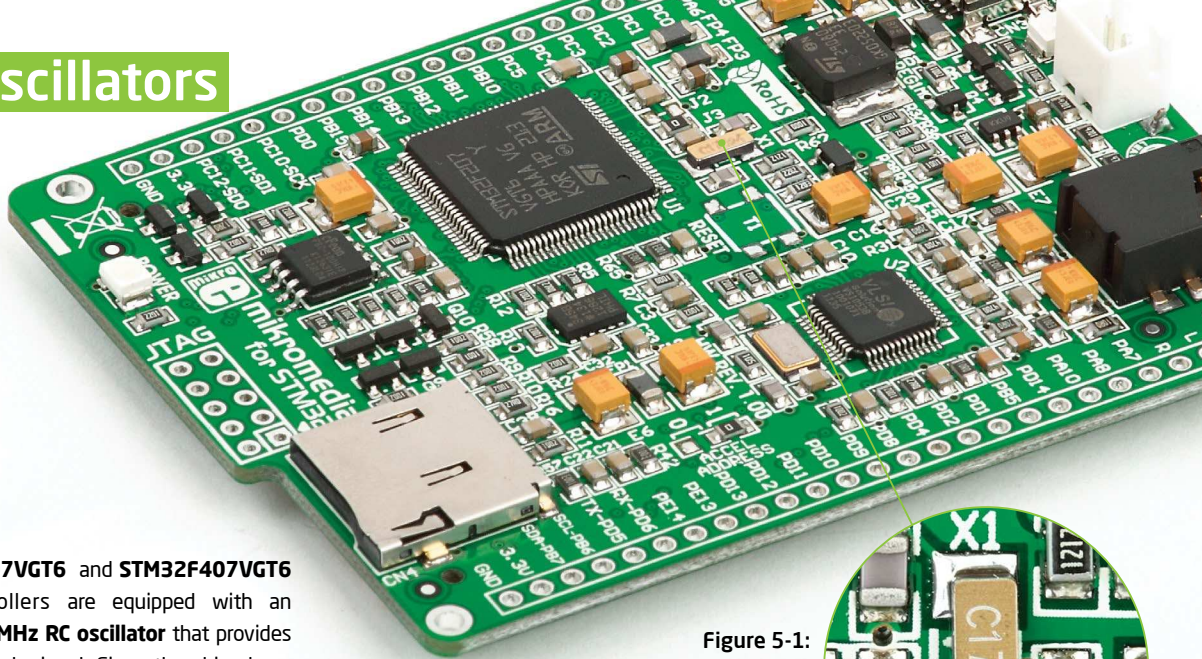
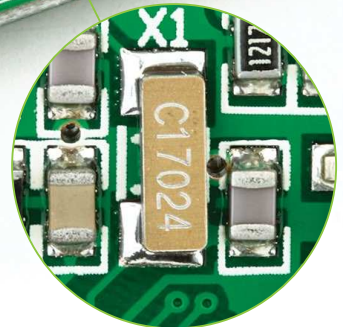

Figure 5-1:
Crystal oscillator
module (X1)



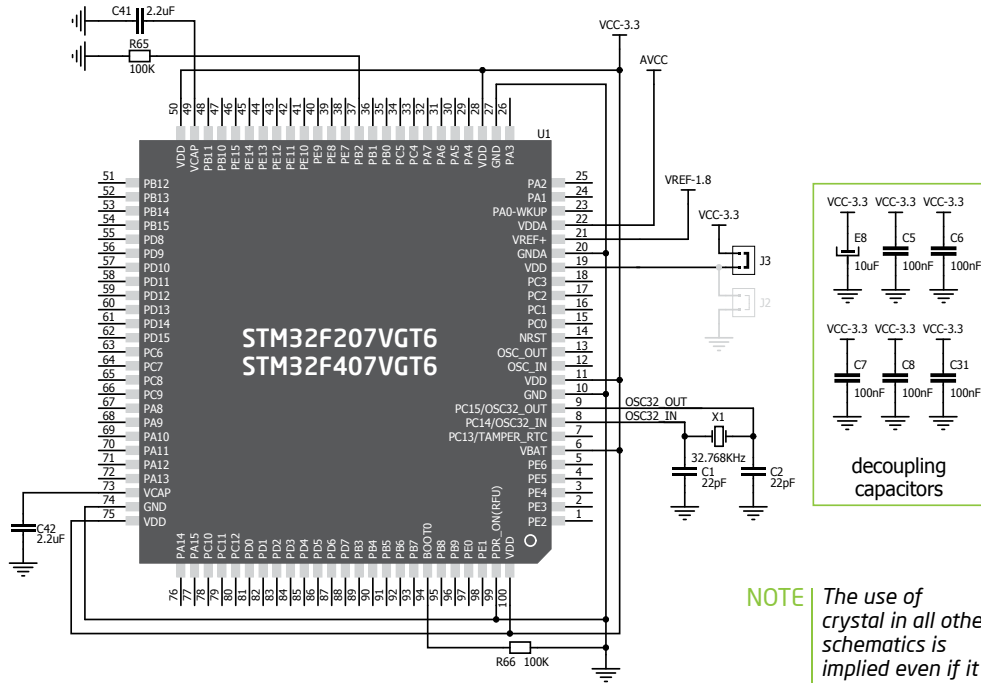
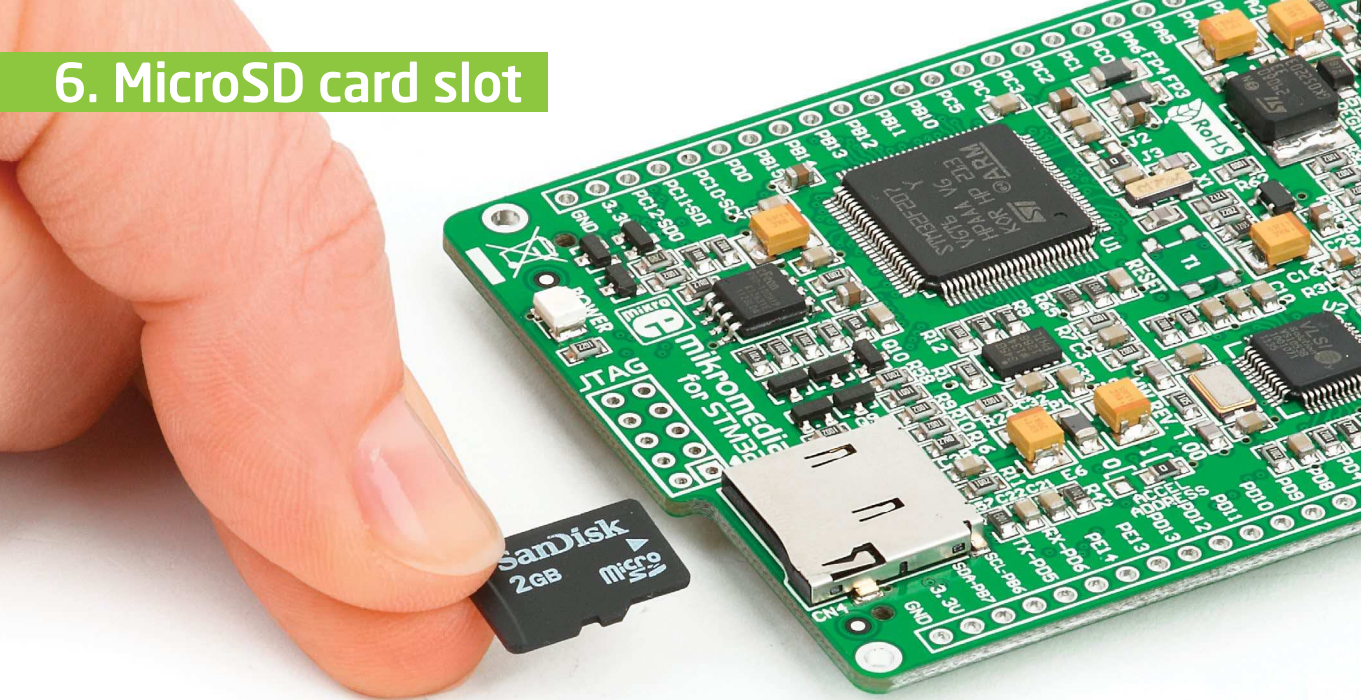

Figure 5-2: Crystal oscillator schematic

NOTE *The use of crystal in all other schematics is implied even if it is purposely left out, because of the schematics clarity.*

6. microSD card slot



Board contains a **microSD card slot** for using microSD cards in your projects. It enables you to store large amounts of data externally, thus saving microcontroller memory. microSD cards use Serial Peripheral Interface (**SPI**) for communication with the microcontroller.

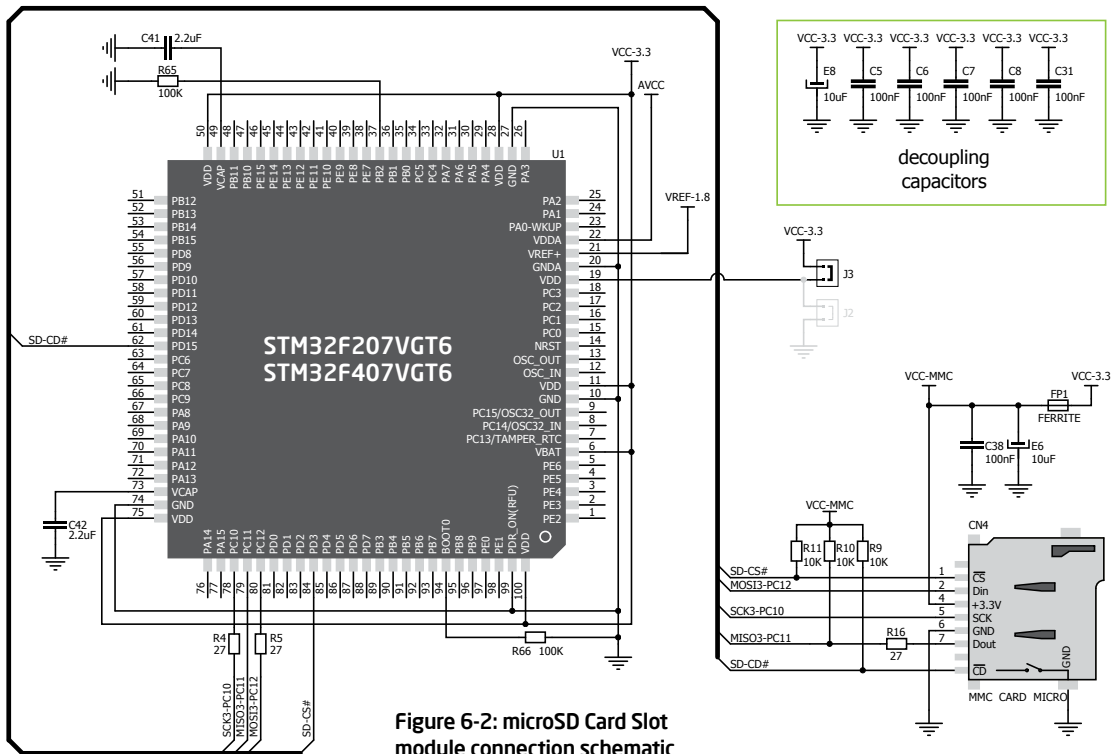

7. Touch screen

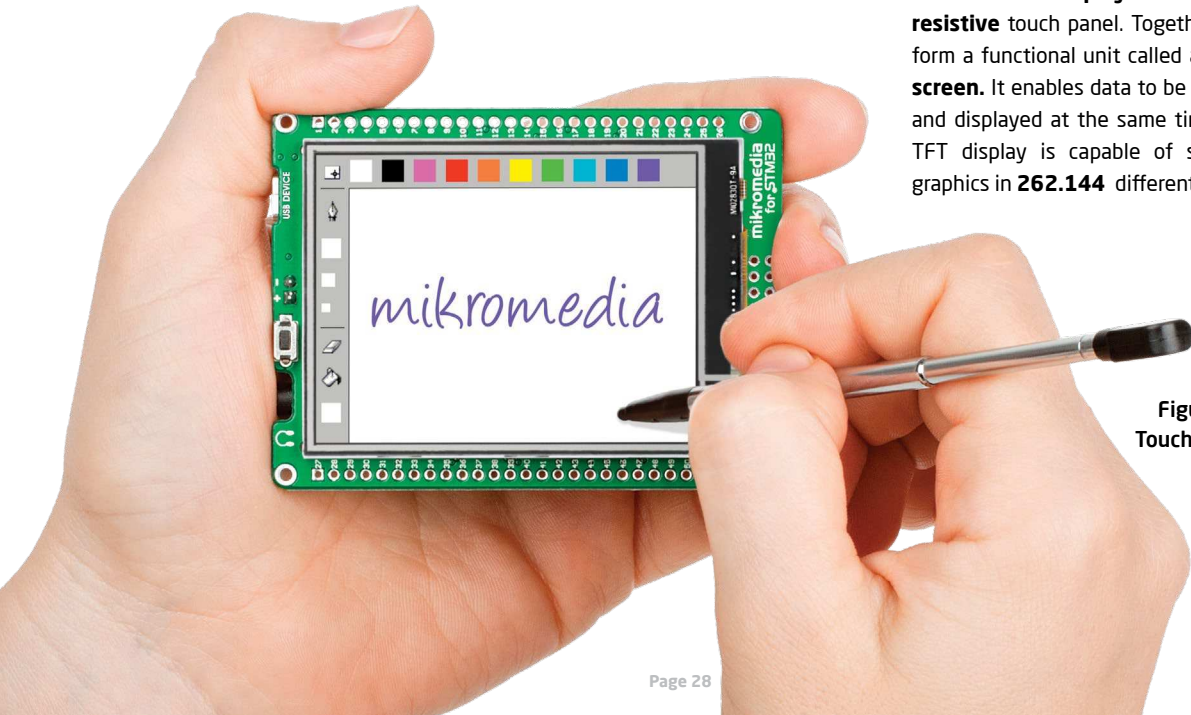

The development system features a **TFT 320x240 display** covered with a **resistive** touch panel. Together they form a functional unit called a **touch screen**. It enables data to be entered and displayed at the same time. The TFT display is capable of showing graphics in **262.144** different colors.

Figure 7-1:
Touch Screen

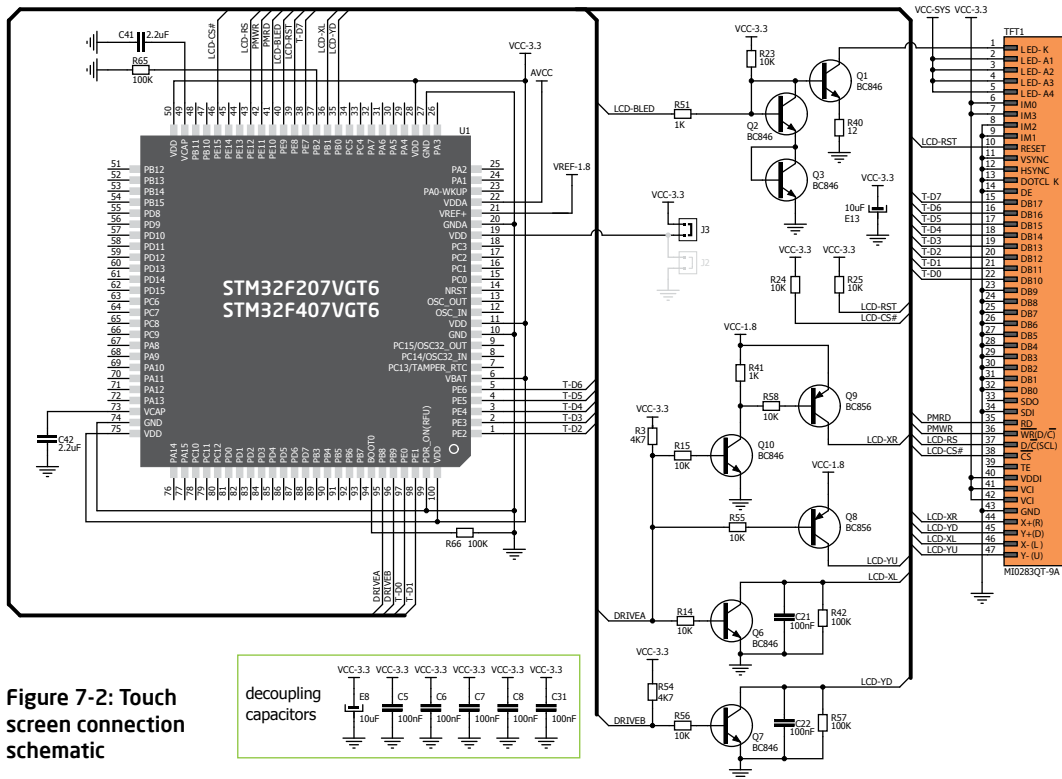
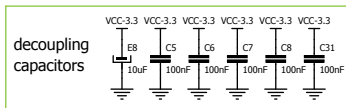

Figure 7-2: Touch screen connection schematic



8. Audio module

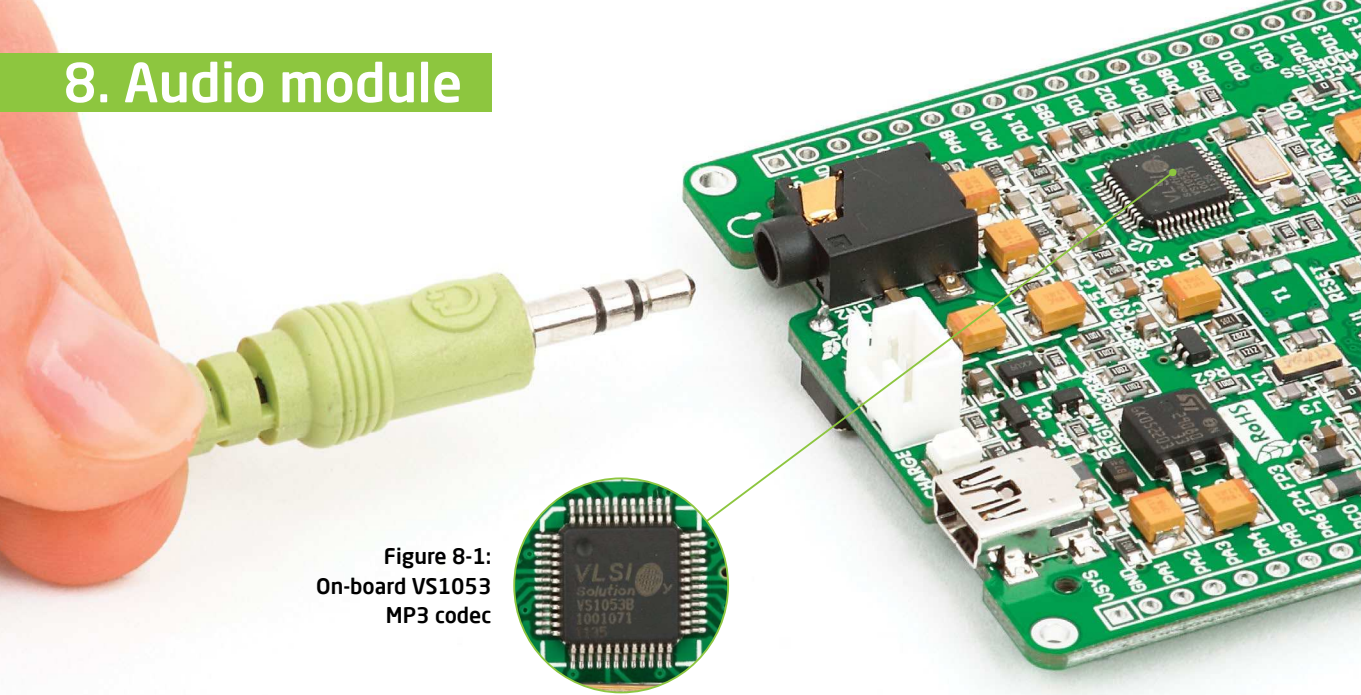

Figure 8-1:
On-board VS1053
MP3 codec

mikromedia for STM32® features a stereo audio codec **VS1053**. This module enables audio reproduction by using stereo headphones connected to the system via a **3.5mm** connector CN2. All functions of this module are controlled by the microcontroller over Serial Peripheral Interface (**SPI**).

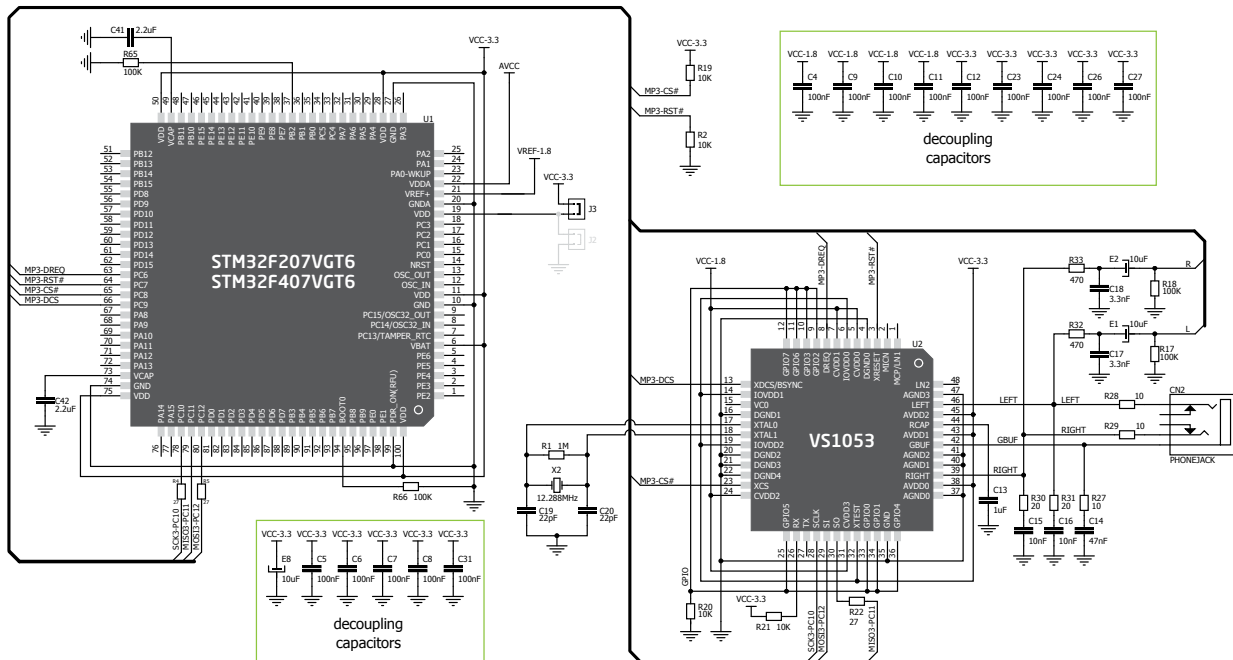

Figure 8-3: Audio module connection schematic

9. USB connection

Figure 9-1:
Connecting
USB cable to
programming
connector



STM32F207VGT6 and **STM32F407VGT6** microcontrollers have an integrated USB module, which enables you to implement USB communication functionality to your mikromedia board. Connection with target USB host is done over a Mini-B USB connector which is positioned next to the battery connector.

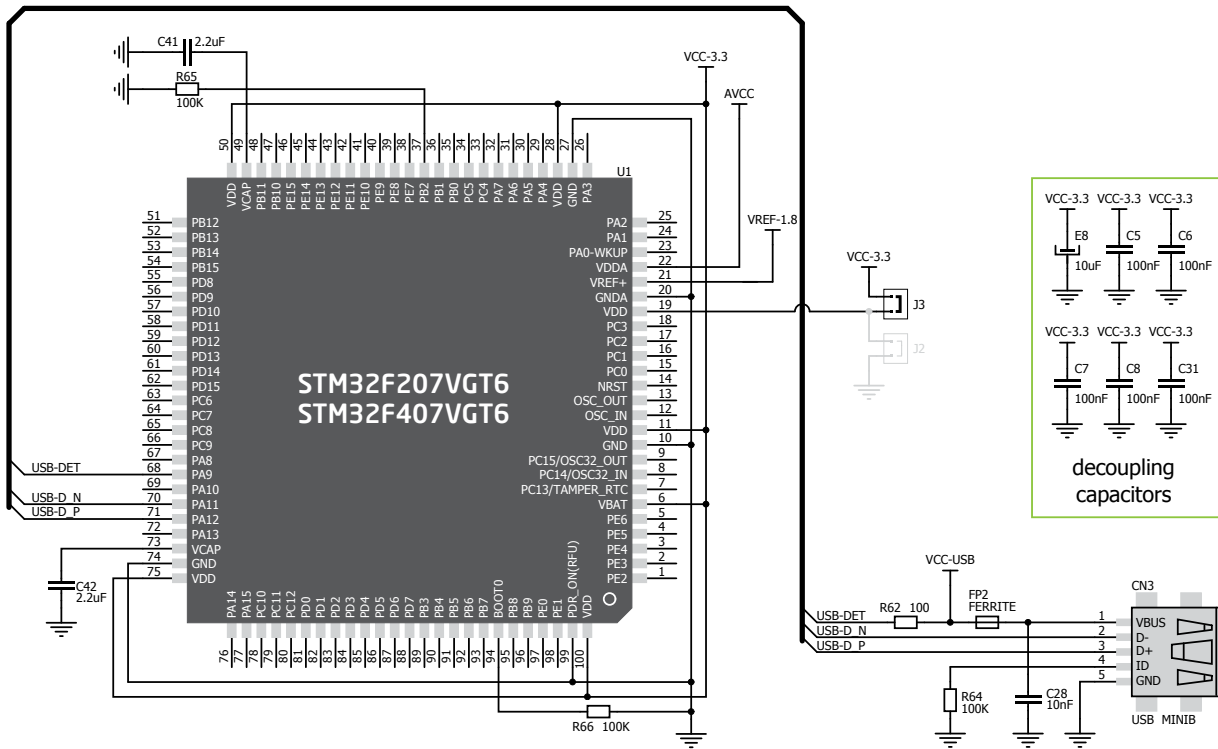

Figure 9-2: USB module connection schematic

10. Accelerometer

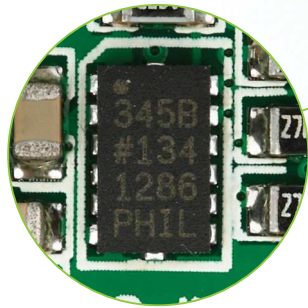
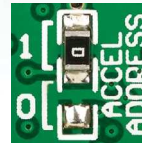

Figure 10-1:
Accelerometer
module

On board **ADXL345** accelerometer is used to measure acceleration in three axes: x, y and z. The accelerometer's function is defined by the user in the program loaded into the microcontroller. Communication between the accelerometer and the microcontroller is performed via the **I²C** interface.



You can set the accelerometer address to 0 or 1 by re-soldering the SMD jumper (zero-ohm resistor) to the appropriate position. Jumper is placed in address 1 position by default.

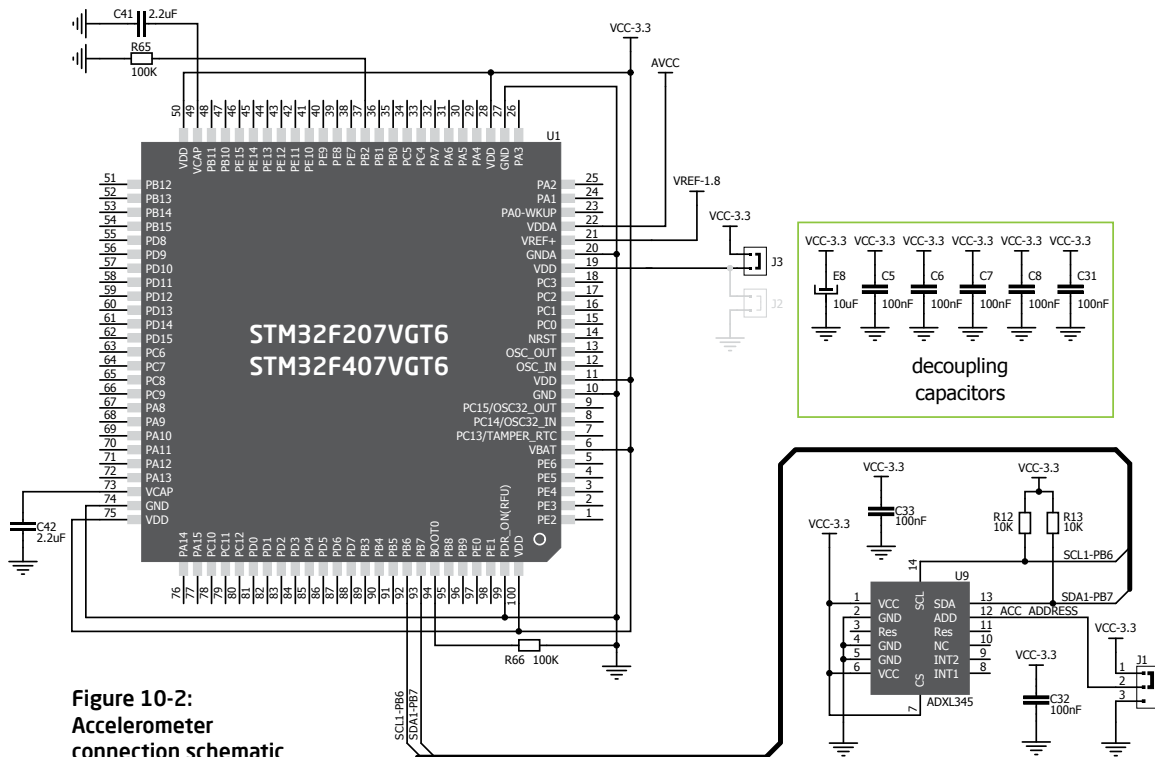
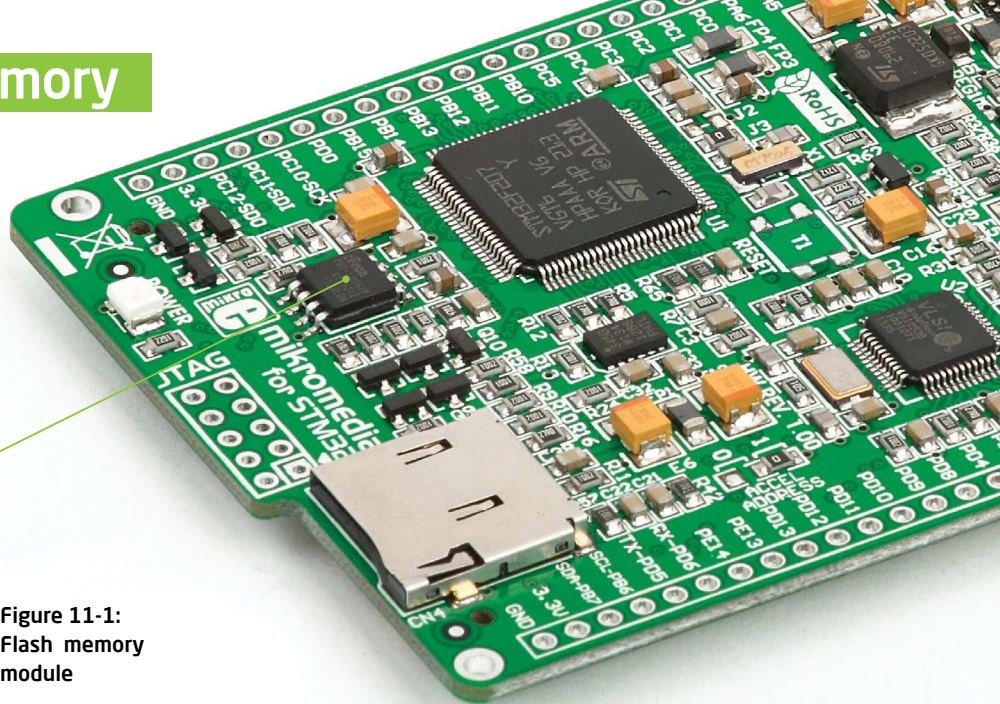

Figure 10-2:
Accelerometer
connection schematic

11. Flash memory



Figure 11-1:
Flash memory
module



Since multimedia applications are getting increasingly demanding, it is necessary to provide additional memory space to be used for storing more data. The flash memory module enables the microcontroller to use additional **8Mbit** flash memory. It is connected to the microcontroller via the Serial Peripheral Interface (**SPI**).

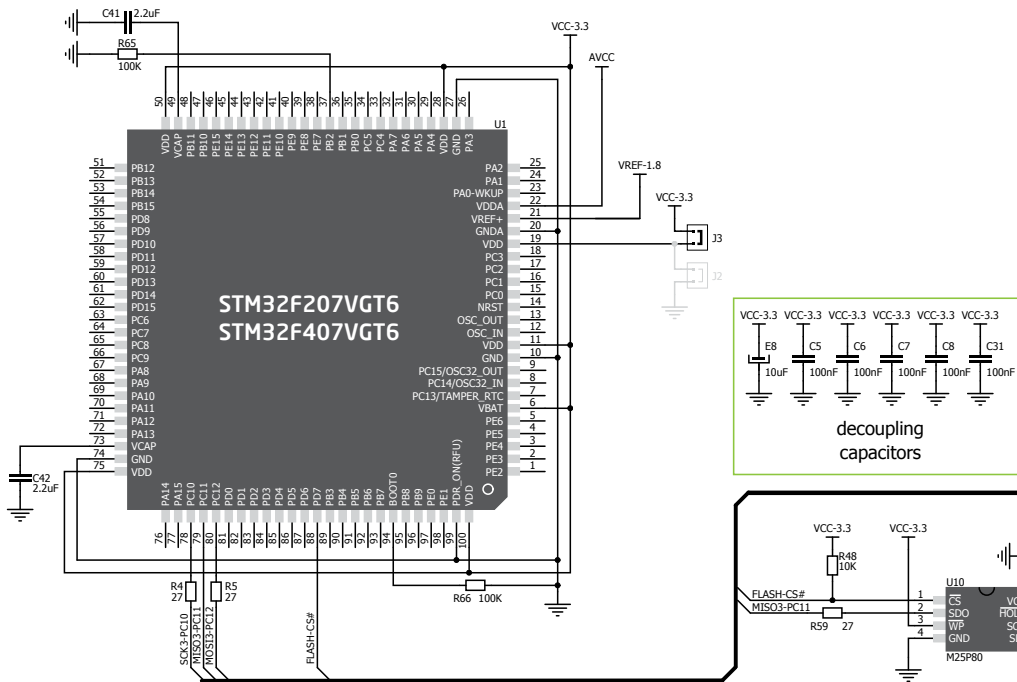
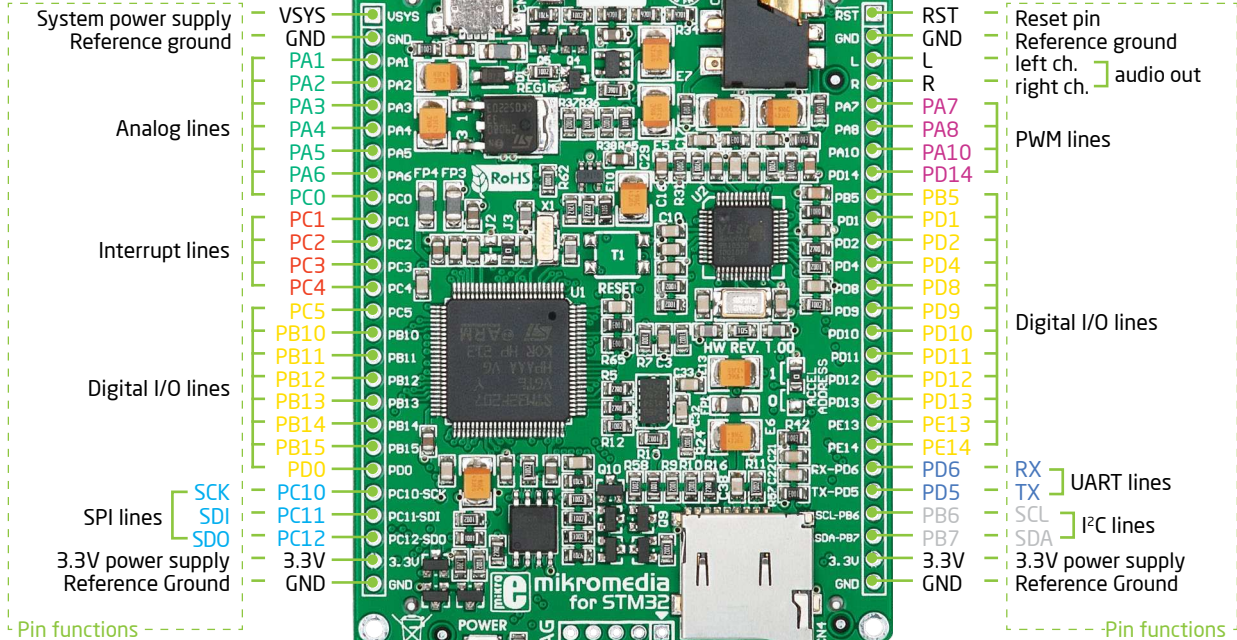

Figure 11-2: Flash memory module connection schematic

13. Pinout



■ Digital lines
 ■ Analog lines
 ■ Interrupt lines
 ■ SPI lines
 ■ I²C lines
 ■ UART lines
 ■ PWM lines

14. Dimensions

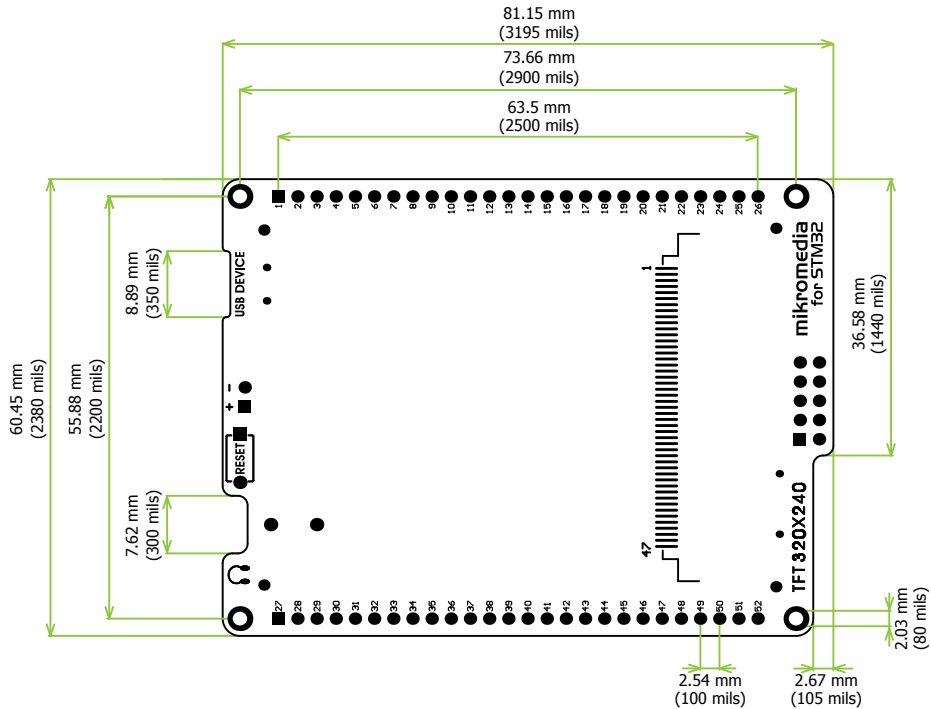

15. mikromedia accessories

We have prepared a set of extension boards pin-compatible with your mikromedia, which enable you to easily expand your board's basic functionality. We call them mikromedia shields. But we also offer other accessories, such as a Li-polymer battery, stacking headers, wire jumpers and more.



01 Connect shield



02 BatteryBoost shield

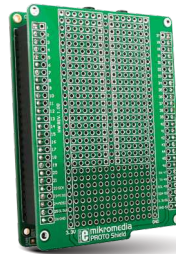

03 PROTO shield

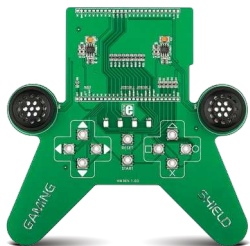

04 Gaming shield



05 Li-Polymer battery



06 Wire jumpers



07 Stacking headers

16. What's next?

You have now completed the journey through each and every feature of mikromedia for STM32. You got to know its modules and organization. Now you are ready to start using your new board. We are suggesting several steps which are probably the best way to begin. Find useful projects and tutorials on the **Libstock** website (www.libstock.com). Join our **Forum** (www.mikroe.com/forum) and get help from a large ecosystem of users.

Compiler

You still don't have an appropriate compiler? Locate ARM compiler that suits you best on our site:



www.mikroe.com/arm/compilers

Choose between mikroC™, mikroBasic™ and mikroPascal™ and download a fully functional demo version, so you can begin building your first applications.

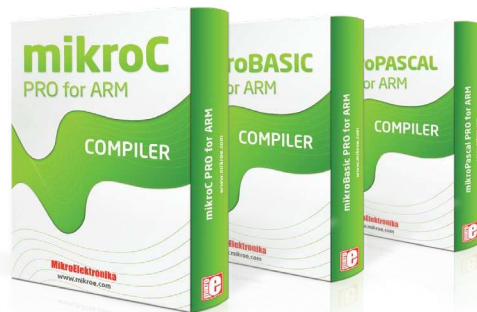

Visual TFT

Once you have chosen your compiler, and since you already got the board, you are ready to start writing your first projects. **Visual TFT software** enables you to quickly create your GUI. It will automatically generate code compatible with MikroElektronika compilers. Visual TFT is rich with examples, which are an excellent starting point for your future projects. Download it from the link below:



www.mikroe.com/visualtft

DISCLAIMER

All the products owned by MikroElektronika are protected by copyright law and international copyright treaty. Therefore, this manual is to be treated as any other copyright material. No part of this manual, including product and software described herein, may be reproduced, stored in a retrieval system, translated or transmitted in any form or by any means, without the prior written permission of MikroElektronika. The manual PDF edition can be printed for private or local use, but not for distribution. Any modification of this manual is prohibited.

MikroElektronika provides this manual 'as is' without warranty of any kind, either expressed or implied, including, but not limited to, the implied warranties or conditions of merchantability or fitness for a particular purpose.

MikroElektronika shall assume no responsibility or liability for any errors, omissions and inaccuracies that may appear in this manual. In no event shall MikroElektronika, its directors, officers, employees or distributors be liable for any indirect, specific, incidental or consequential damages (including damages for loss of business profits and business information, business interruption or any other pecuniary loss) arising out of the use of this manual or product, even if MikroElektronika has been advised of the possibility of such damages. MikroElektronika reserves the right to change information contained in this manual at any time without prior notice, if necessary.

HIGH RISK ACTIVITIES

The products of MikroElektronika are not fault - tolerant nor designed, manufactured or intended for use or resale as on - line control equipment in hazardous environments requiring fail - safe performance, such as in the operation of nuclear facilities, aircraft navigation or communication systems, air traffic control, direct life support machines or weapons systems in which the failure of Software could lead directly to death, personal injury or severe physical or environmental damage ('High Risk Activities'). MikroElektronika and its suppliers specifically disclaim any expressed or implied warranty of fitness for High Risk Activities.

TRADEMARKS

The MikroElektronika name and logo, mikroC™, mikroBasic™, mikroPascal™, Visual TFT™, Visual GLCD™, mikroProg™, Ready™, MINI™, mikroBUS™, EasyPIC™, EasyAVR™, Easy8051™, click™ boards and mikromedia™ are trademarks of MikroElektronika. All other trademarks mentioned herein are property of their respective companies. All other product and corporate names appearing in this manual may or may not be registered trademarks or copyrights of their respective companies, and are only used for identification or explanation and to the owners' benefit, with no intent to infringe.

Copyright © 2014 MikroElektronika. All Rights Reserved.



If you want to learn more about our products, please visit our website at www.mikroe.com

If you are experiencing some problems with any of our products or just need additional information, please place your ticket at www.mikroe.com/support

If you have any questions, comments or business proposals,
do not hesitate to contact us at office@mikroe.com

mikromedia for STM32 M3/M4 manual
ver. 1.00d

