



HESTORE.HU
elektronikai alkatrész áruház

EN: This Datasheet is presented by the manufacturer.

Please visit our website for pricing and availability at www.hestore.hu.



mikromedia™

for PIC18FJ®

Compact development system rich with on-board peripherals for all-round multimedia development on PIC18F87J50 device.



TO OUR VALUED CUSTOMERS

I want to express my thanks to you for being interested in our products and for having confidence in MikroElektronika.

The primary aim of our company is to design and produce high quality electronic products and to constantly improve the performance thereof in order to better suit your needs.

A handwritten signature in white ink, appearing to read 'N. Matic', is positioned on the right side of the page. The signature is fluid and cursive, with a large initial 'N' and 'M'.

Nebojsa Matic
General Manager

Table of Contents

Introduction to mikromedia™ for PIC18FJ®	4	Programing with mikroProg™ programmer	16
Package Contains	5	mikroProg Suite™ for PIC® Software	17
Key Features	6	Programing with ICD2® or ICD3® programmer	18
System Specification	7	5. Crystal oscillator	20
1. USB power supply	8	6. microSD Card Slot	21
2. Battery power supply	9	7. Touch Screen	22
3. Microcontroller PIC18F87J50	10	8. Audio Module	24
Key microcontroller features	10	9. USB connection	26
4. Programming the microcontroller	11	10. Accelerometer	28
Programming with mikroBootloader	12	11. Flash Memory	29
step 1 - Connecting mikromedia	12	12. Pads	30
step 2 - Browsing for .hex file	13	13. Pinout	31
step 3 - Select .hex file	13	14. Dimensions	32
step 4 - .hex file uploading	14	15. mikromedia Accessories	33
step 5 - Finish upload	15	16. What's Next?	34

Introduction to mikromedia™ for PIC18FJ®

The **mikromedia™ for PIC18FJ®** is a compact development system with lots of on-board peripherals which allow development of devices with multimedia contents. The central part of the system is a 8-bit **PIC18F87J50** microcontroller. The mikromedia™ for PIC18FJ® features integrated modules such as stereo MP3 codec, **TFT 320x240 touch screen** display, accelerometer, USB connector, MMC/SD card slot and other. It comes pre-programmed with USB bootloader, but can also be programmed with external programmers, such as mikroProg™ or ICD2/3®. Mikromedia is compact and slim, and perfectly fits in the palm of the hand, which makes it convenient platform for mobile devices.

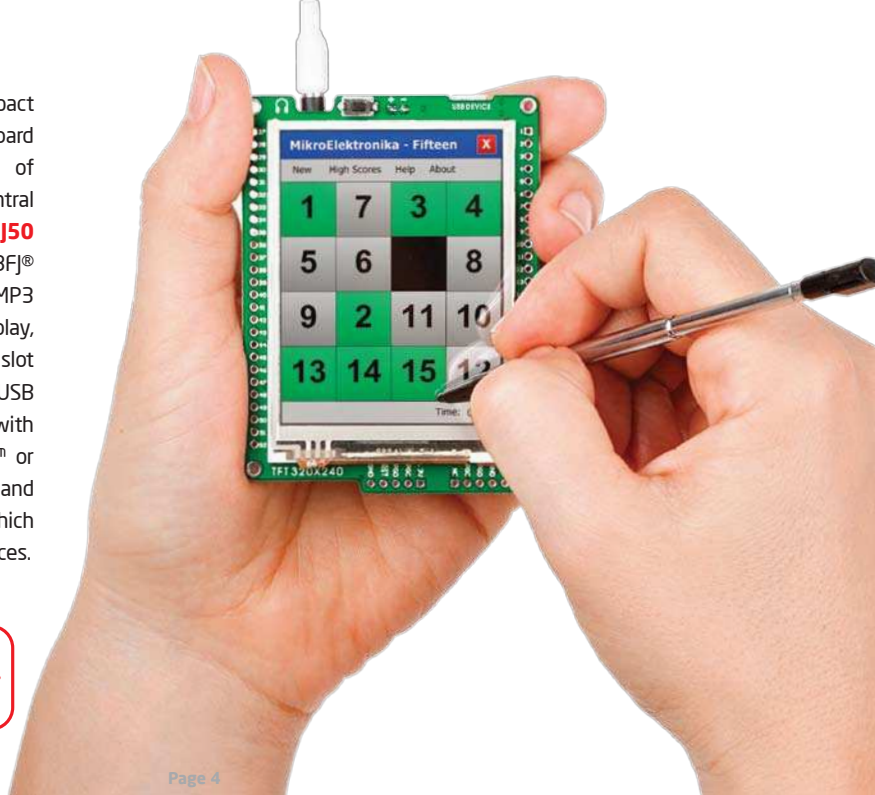

Package Contains



- 01 Damage resistant protective box



- 02 mikromedia™ for PIC18FJ® development system



- 03 DVD with documentation and examples



- 04 mikromedia™ for PIC18FJ® user's guide



- 05 mikromedia™ for PIC18FJ® schematic



- 06 USB cable

Key Features

- 01 Connection Pads
- 02 TFT 320x240 display
- 03 USB MINI-B connector
- 04 LI-Polymer battery connector
- 05 3.5mm headphone connector
- 06 Power supply regulator
- 07 Serial Flash memory
- 08 VS1053 Stereo mp3 coder/decoder
- 09 RESET button
- 10 PIC18F87J50 microcontroller
- 11 Accelerometer
- 12 Crystal oscillator
- 13 Power indicator LED
- 14 microSD Card Slot
- 15 ICD2/3® connector
- 16 mikroProg™ connector

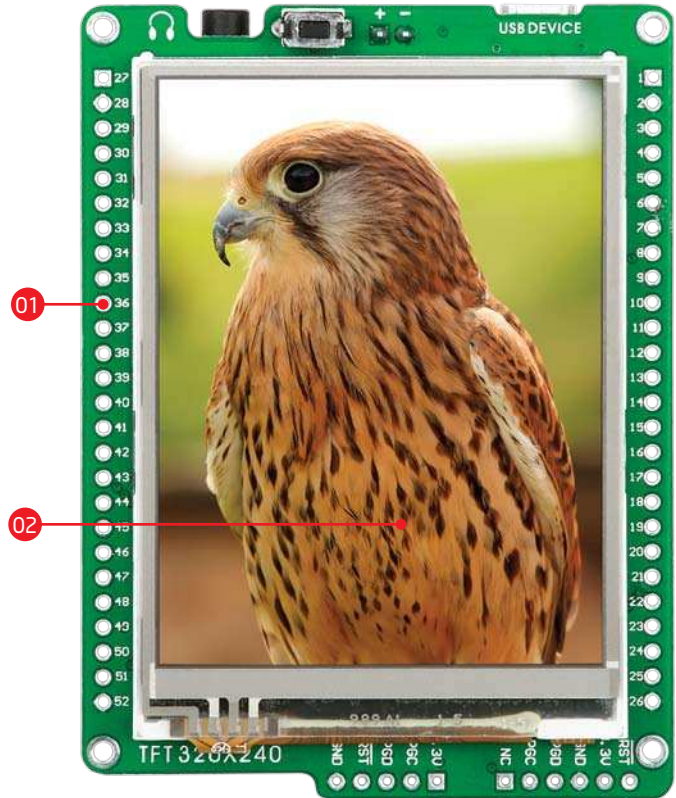

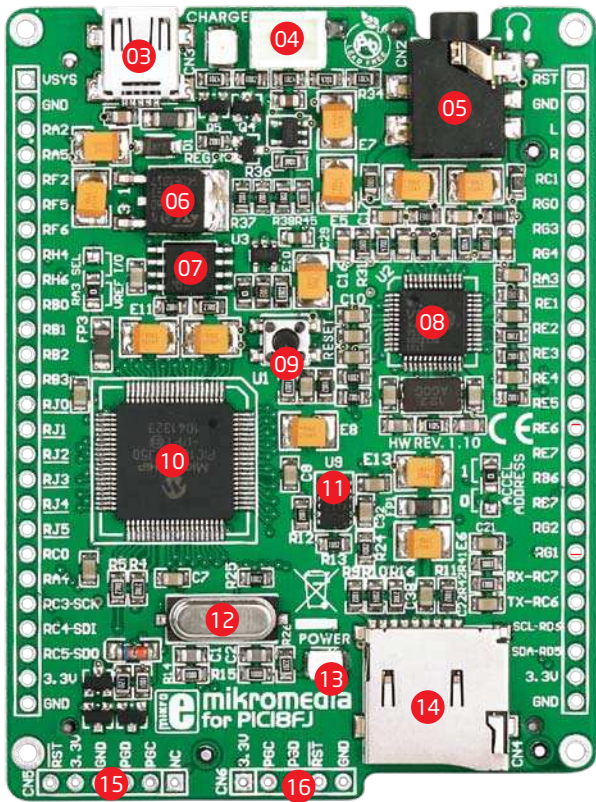

System Specification



power supply

Over a USB cable (5V DC)



power consumption

53 mA with erased MCU
(when on-board modules are inactive)



board dimensions

8 x 6cm (3.14 x 2.36 inch)



weight

~45,5g (0.10 lbs)

1. USB power supply

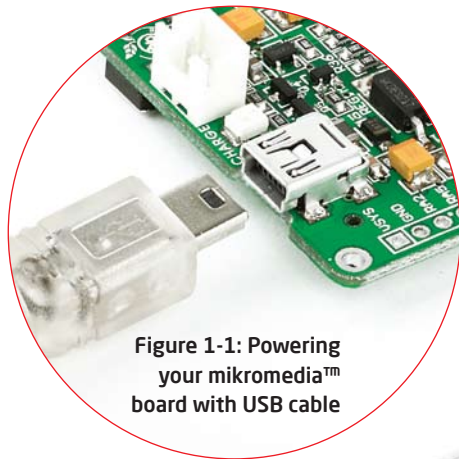
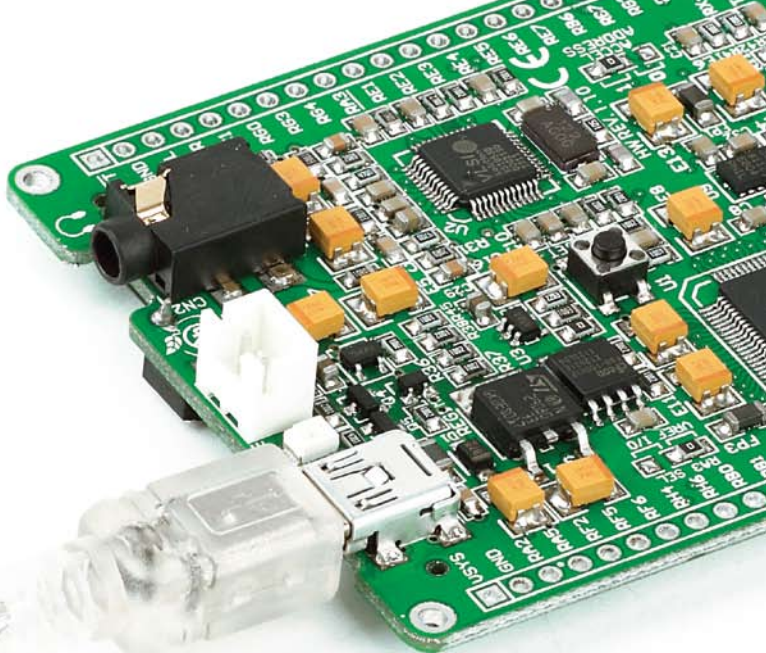

Figure 1-1: Powering your mikromedia™ board with USB cable



You can apply power supply to the board using **MINI-B USB** cable provided with the board. On-board voltage regulators will make sure to regulate the appropriate voltage levels to each part of the board. Power LED will indicate the presence of power supply.

2. Battery power supply



Figure 2-1:
Connecting Li-polymer battery
to mikromedia™ board

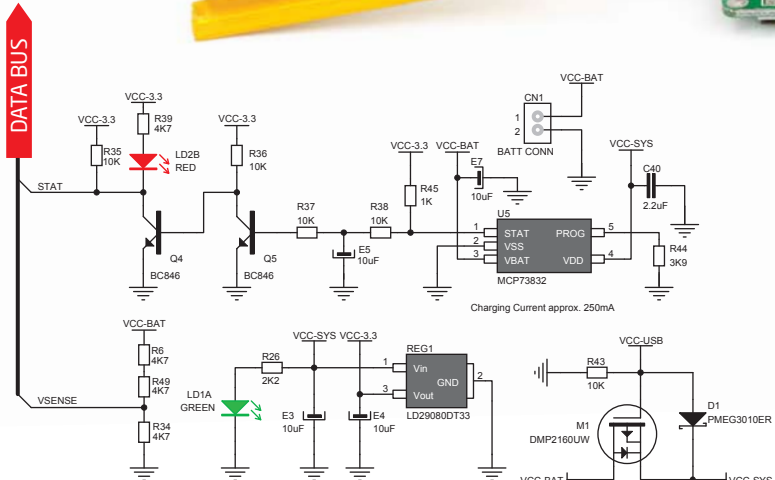

You can also power the board using **Li-Polymer** battery, via on-board battery connector. On-board battery charger circuit **MCP73832** enables you to charge the battery over USB connection. Charging current is $\sim 250\text{mA}$ and charging voltage is 4.2V DC.

Figure 2-2:
Battery charger and power management
connection schematic

3. Microcontroller PIC18F87J50

The mikromedia™ for PIC18F® development system comes with the **PIC18F87J50** microcontroller. This high-performance 8-bit microcontroller with its integrated modules and in combination with other on-board modules is ideal for multimedia applications.

Key microcontroller features

- USB V2.0 Compliant SIE;
- Two External Clock modes, up to 48 MHz;
- Internal 31 kHz Oscillator, Tunable Internal Oscillator; 31 kHz to 8 MHz;
- 10-Bit, up to 12-Channel Analog-to-Digital (A/D);
- Address Capability of up to 2 Mbytes;
- 8-Bit or 16-Bit Interface;
- 12-Bit, 16-Bit and 20-Bit Addressing modes; etc.

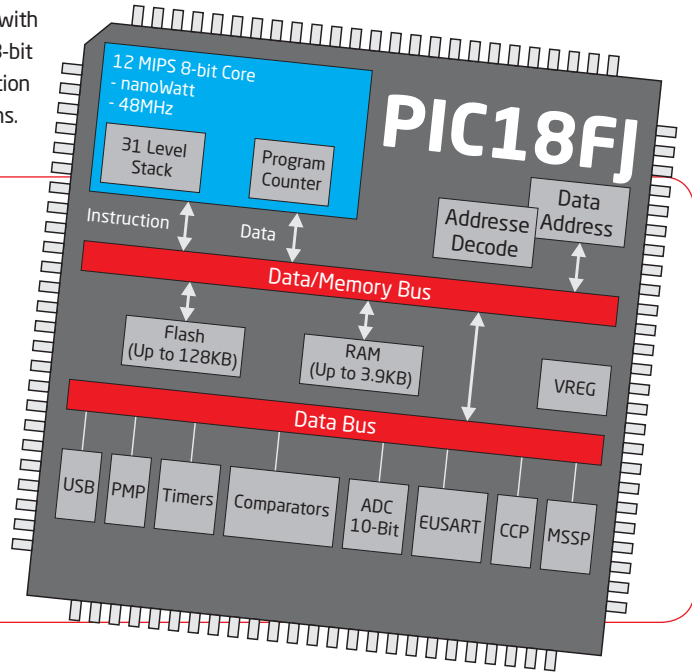

4. Programming the microcontroller

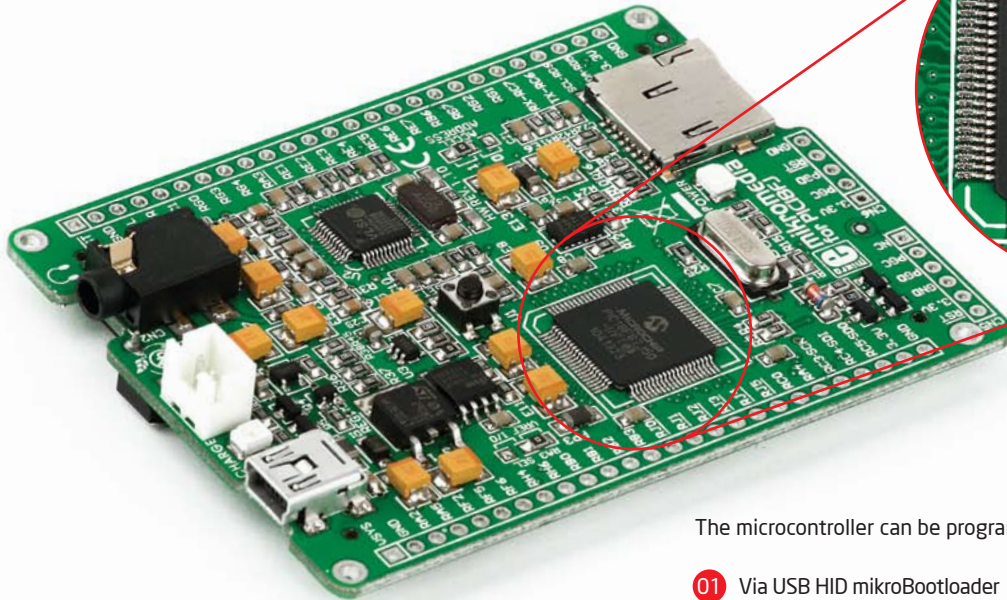

Figure 4-1:
PIC18F87J50
Microcontroller

The microcontroller can be programmed in three ways:

- 01 Via USB HID mikroBootloader
- 02 Using mikroProg™ external programmer
- 03 Using ICD2/3® external programmer

Programming with mikroBootloader

You can program the microcontroller with bootloader which is preprogrammed into the device by default. To transfer .hex file from a PC to MCU you need bootloader software (**mikroBootloader USB HID**) which can be downloaded from:



<http://www.mikroe.com/eng/products/view/585/mikromedia-for-pic18fj/>

After software is downloaded unzip it to desired location and start mikroBootloader USB HID software.

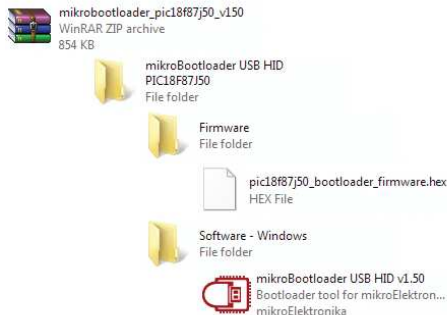

step 1 - Connecting mikromedia



Figure 4-2: mikroBootloader USB HID

- 01 Connect mikromedia™ board with a PC via USB cable and USB icon will turn red.
- 02 Click the **Connect button** within 5s, otherwise existing microcontroller program will execute.

step 2 - Browsing for .hex file



Figure 4-3: Browse for HEX

01 Click on **Browse for HEX** button

step 3 - Select .hex file

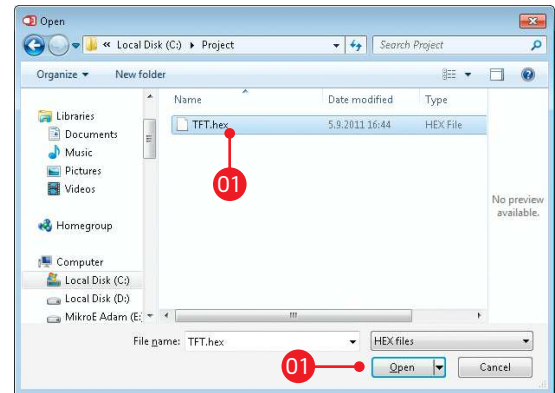

Figure 4-4: Selecting HEX

01 Select .hex file via open window

02 Click on **Open** button

step 4 - .hex file uploading



Figure 4-5: Begin uploading

01 To start .hex file uploading click on **Begin uploading button**

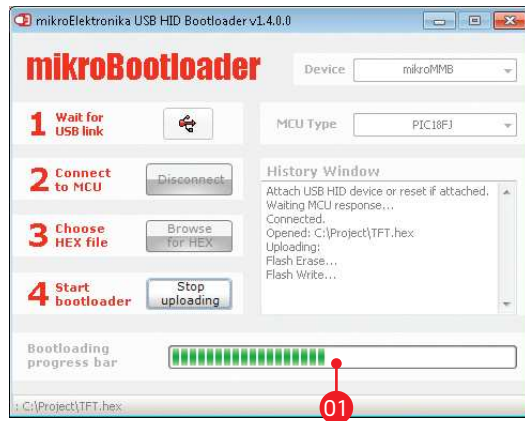

Figure 4-6: Progress bar

01 You can monitor .hex file uploading via progress bar

step 5 - Finish upload



Figure 4-7: Restarting MCU

01 To finish uploading click on **OK button**



Figure 4-8: mikroBootloader ready for next job

Programming with mikroProg™

programmer

The microcontroller can be programmed with **mikroProg™ programmer** and **mikroProg Suite™ fo PIC®** software. The mikroProg™ programmer is connected to the development system via the CN6 connector, Figure 4-9.



Figure 4-9:
Connecting mikroProg™ to mikroMedia™

mikroProg™ is a fast USB 2.0 programmer with mikroICD™ hardware In-Circuit Debugger. Smart engineering allows mikroProg™ to support PIC10®, PIC12®, PIC16®, PIC18®, dsPIC30/33®, PIC24® and PIC32® devices in a single programmer. It supports over 570 microcontrollers from Microchip®. Outstanding performance, easy operation and elegant design are it's key features.

mikroProg Suite™ for PIC® Software



mikroProg™ programmer requires special programming software called **mikroProg Suite™ for PIC®**. This software is used for programming ALL of Microchip® microcontroller families, including PIC10®, PIC12®, PIC16®, PIC18®, dsPIC30/33®, PIC24® and PIC32®. Software has intuitive interface and SingleClick™ programming technology. Just by downloading the latest version of **mikroProg Suite™** your programmer is ready to program new devices. **mikroProg Suite™** is updated regularly, at least four times a year, so your programmer will be more and more powerful with each new release.

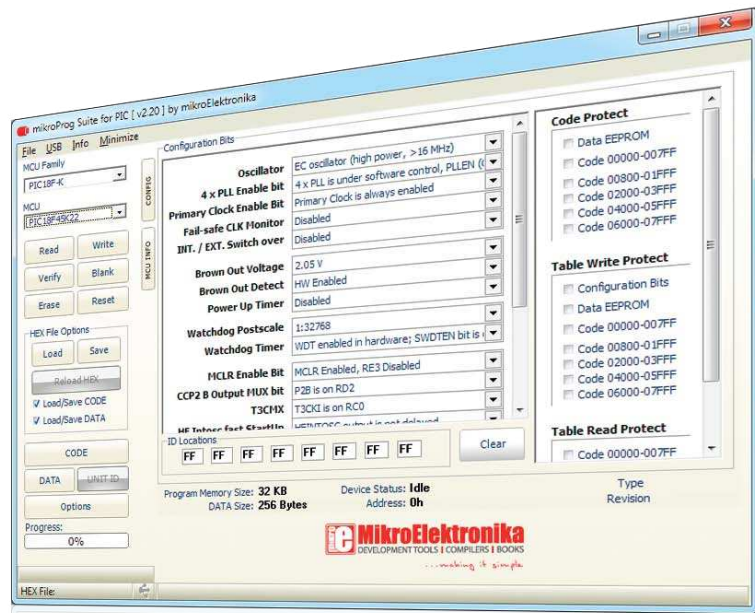

Figure 4-10: Main Window of mikroProg Suite™ for PIC® programming software

Programming with ICD2® or ICD3® programmer

The microcontroller can be also programmed with **ICD2®** or **ICD3® programmer**. These programmers connect with mikromedia board via **ICD2 CONNECTOR BOARD**.

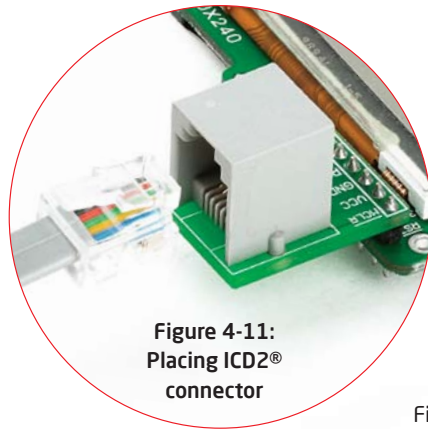

Figure 4-11:
Placing ICD2®
connector

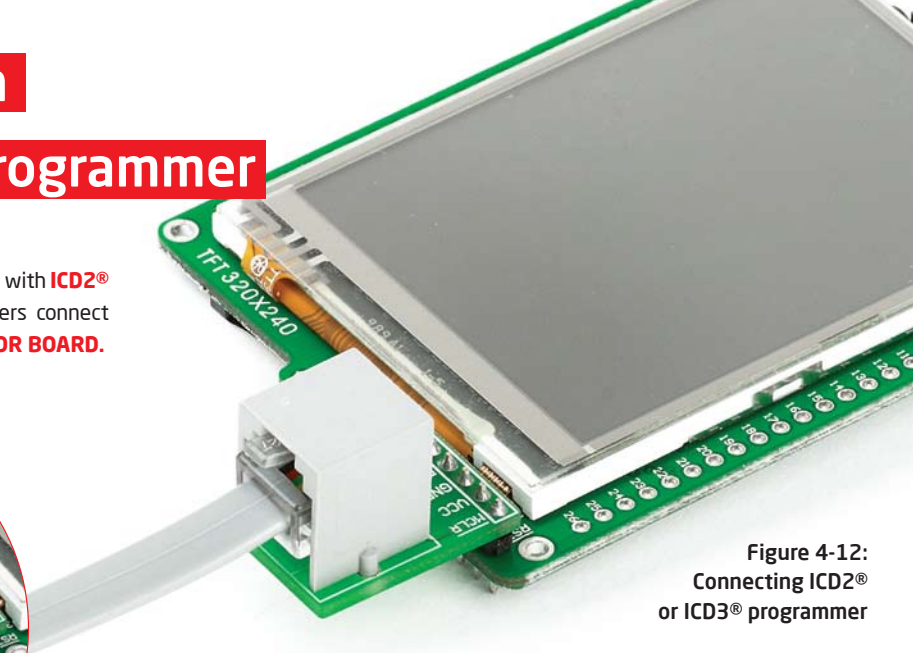

Figure 4-12:
Connecting ICD2®
or ICD3® programmer

In order to enable the ICD2® and ICD3® programmers to be connected to the development system, it is necessary to provide the appropriate connector such as the **ICD2 CONNECTOR BOARD**. This connector should be first soldered on the CN5 connector, Figure 4-12. Then you should plug the ICD2® or ICD3® programmer into it, Figure 4-11.

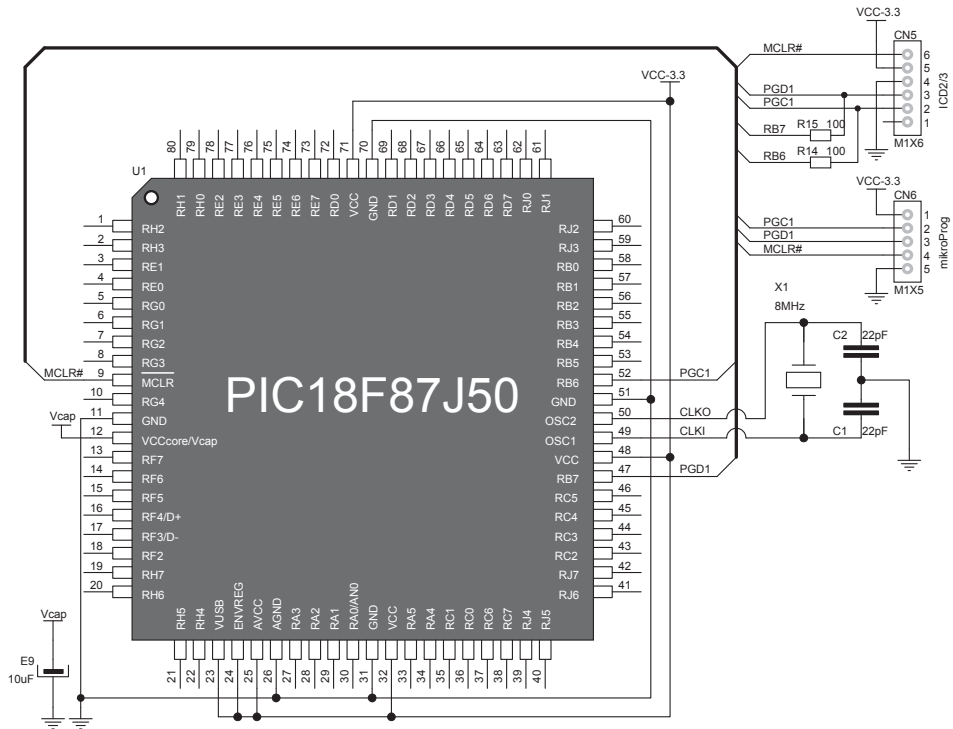

Figure 4-13: mikroProg™ and ICD2®/ICD3® programmer connection schematic

7. Touch Screen

The development system features a **TFT 320x240 display** covered with a **resistive** touch panel. Together they form a functional unit called a **touch screen**. It enables data to be entered and displayed at the same time. The TFT display is capable of showing data in **262.000** different **colors**.

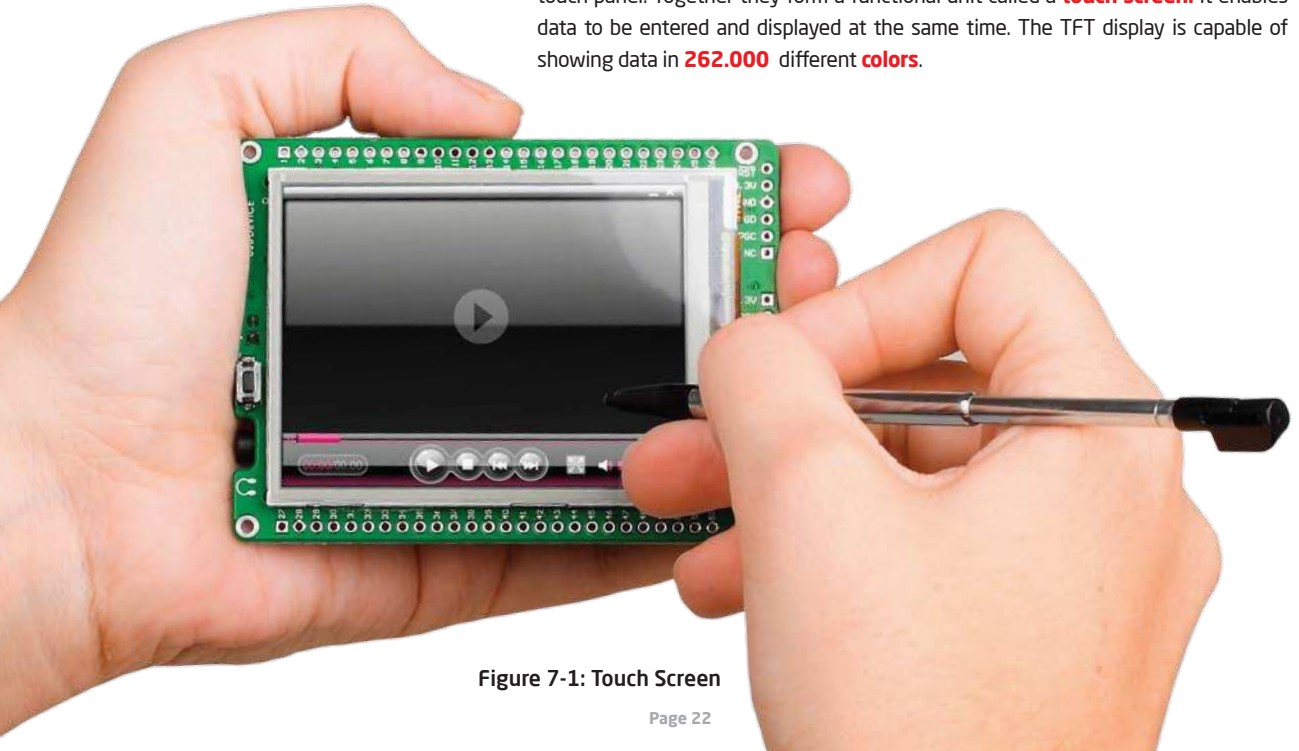

Figure 7-1: Touch Screen

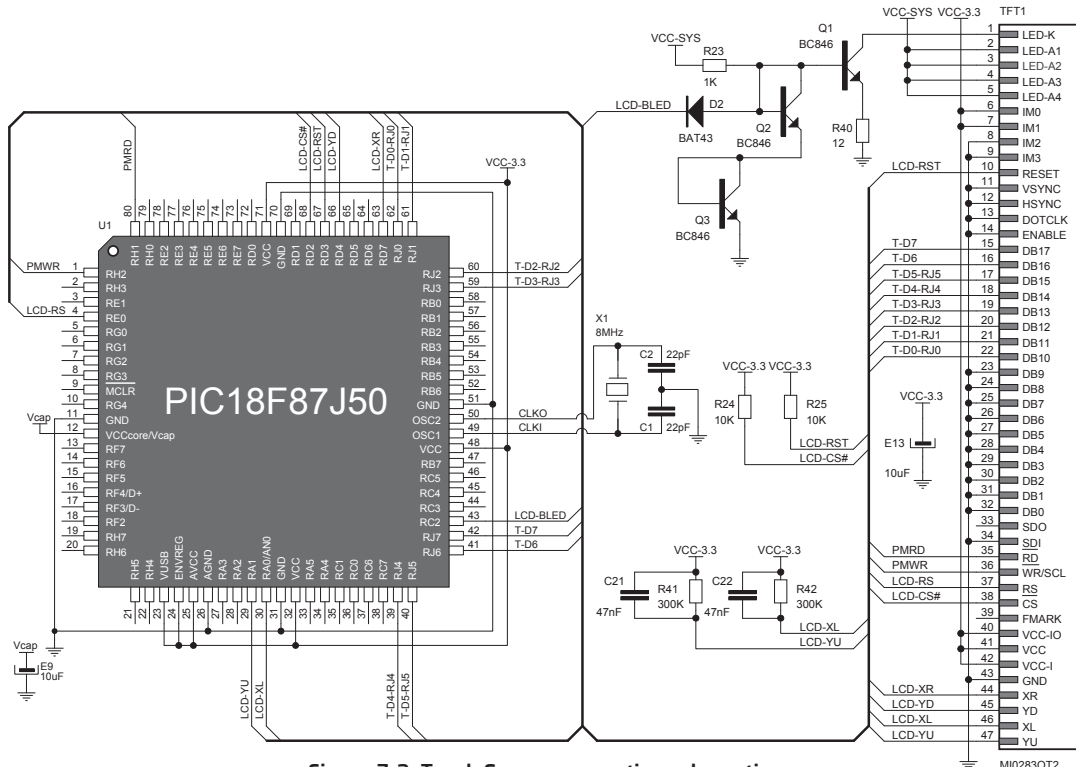

Figure 7-2: Touch Screen connection schematic

8. Audio Module

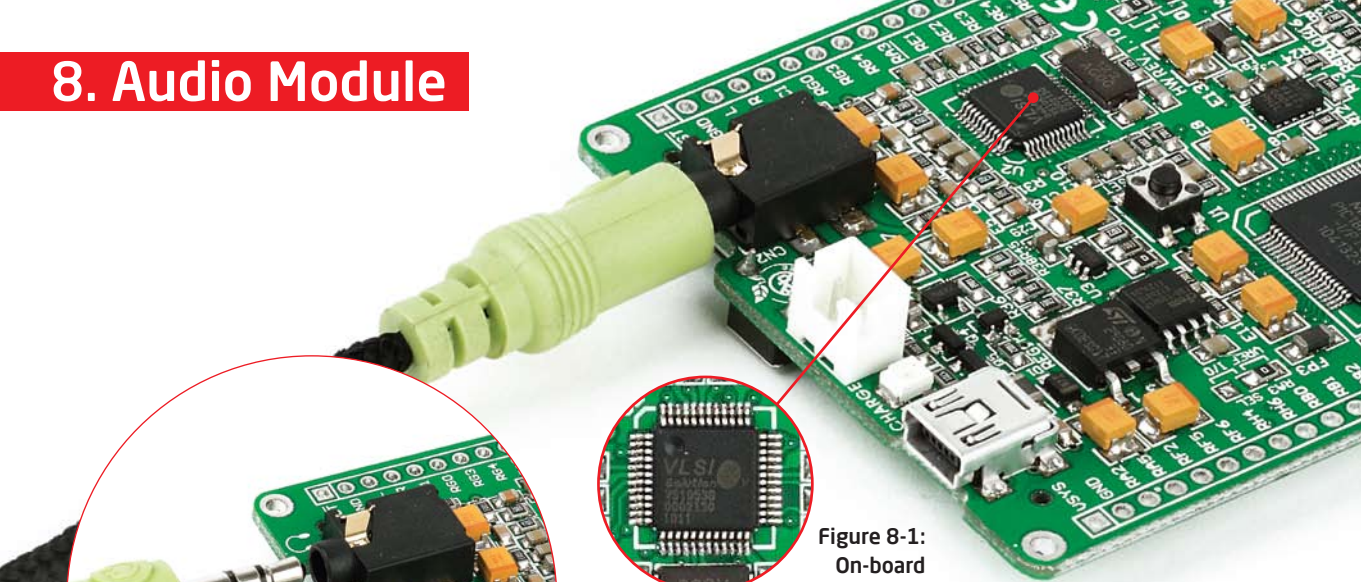

Figure 8-1:
On-board
VS1053
MP3 codec

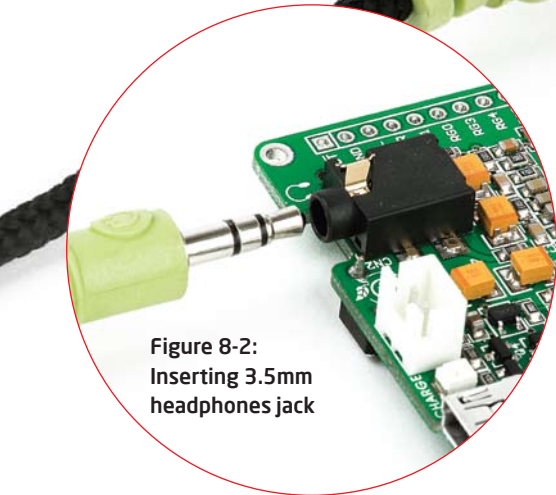

Figure 8-2:
Inserting 3.5mm
headphones jack

The mikromedia™ for PIC18FJ® features MP3 codec audio controller **VS1053**. This module enables audio reproduction by using stereo headphones connected to the system via a **3.5mm** connector CN2. All functions of this module are controlled by the microcontroller over Serial Peripheral Interface (**SPI**).

9. USB connection

PIC18F87J50 microcontroller has integrated USB module, which enables you to implement USB communication functionality of your mikromedia board. Connection with target USB host is done over MINI-B USB connector which is positioned next to the battery connector.

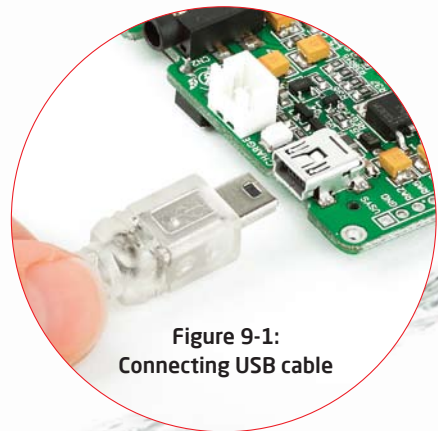
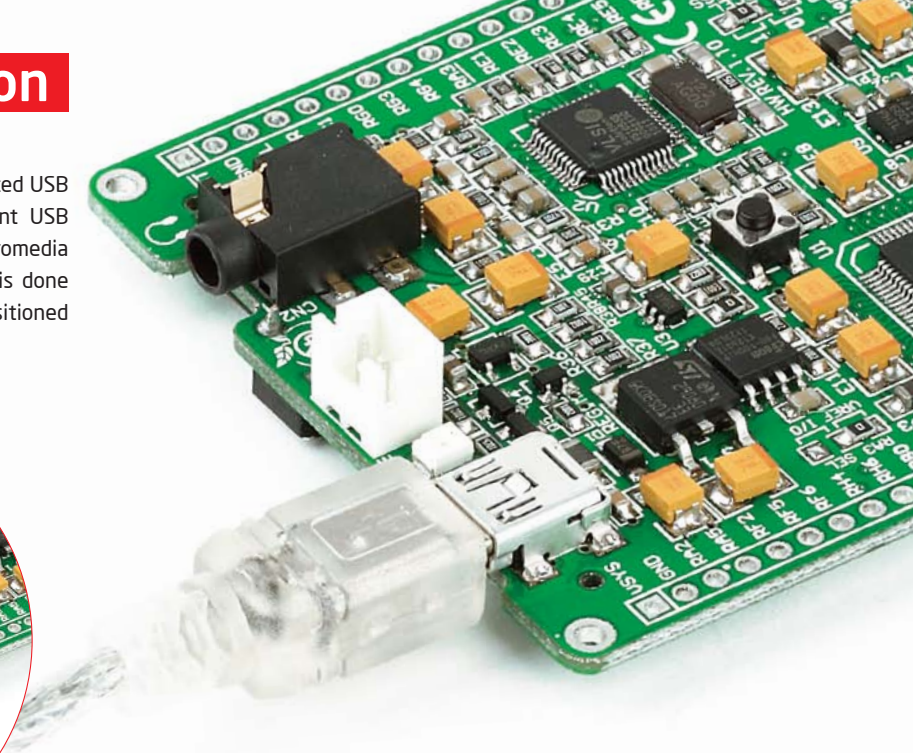

Figure 9-1:
Connecting USB cable



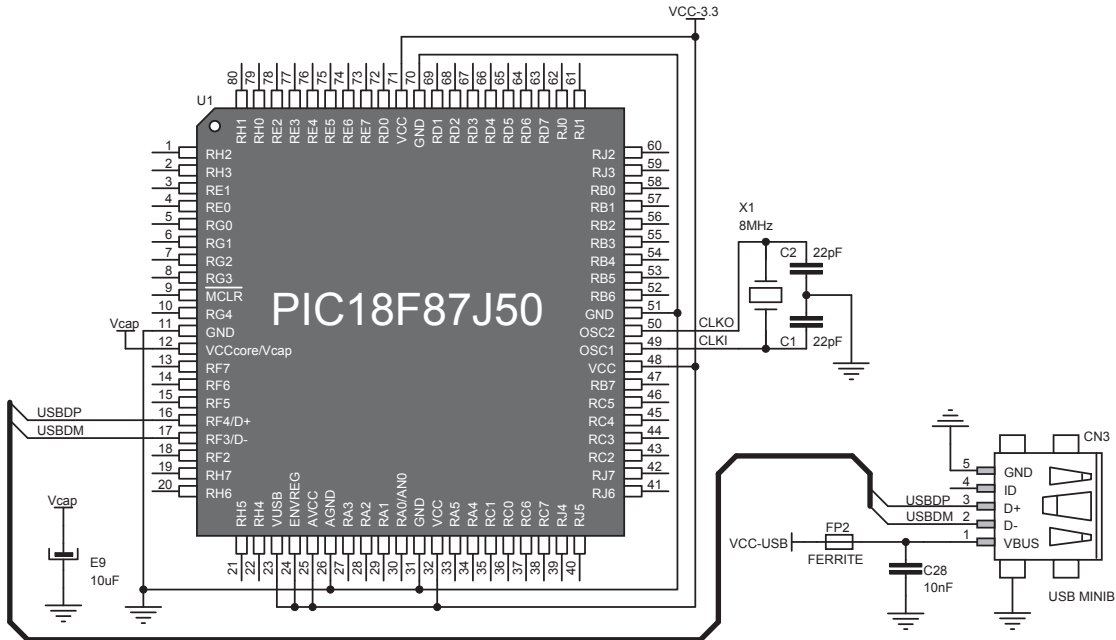

Figure 9-2: USB module connection schematic

10. Accelerometer

On board **ADXL345** accelerometer is used to measure acceleration in three axis: x- y- and z-. The accelerometer function is defined by the user in the program loaded into the microcontroller. Communication between the accelerometer and the microcontroller is performed over the **I²C** interface.

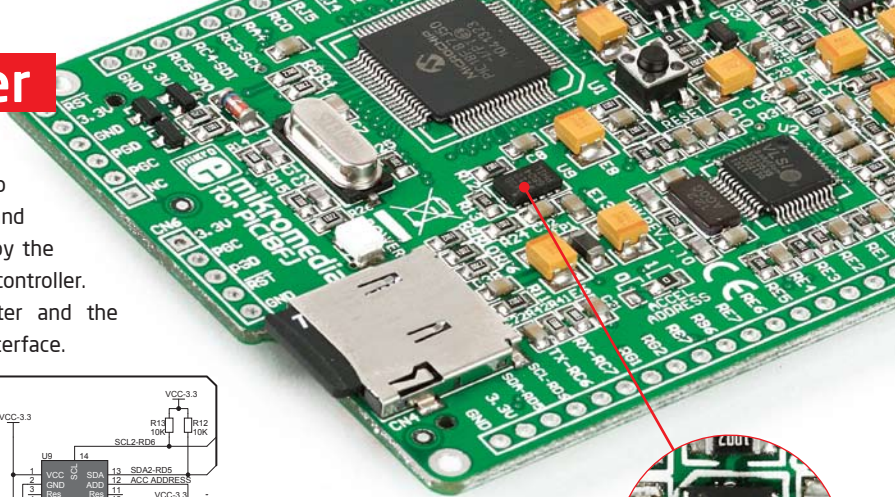

Figure 10-1:
Accelerometer
module

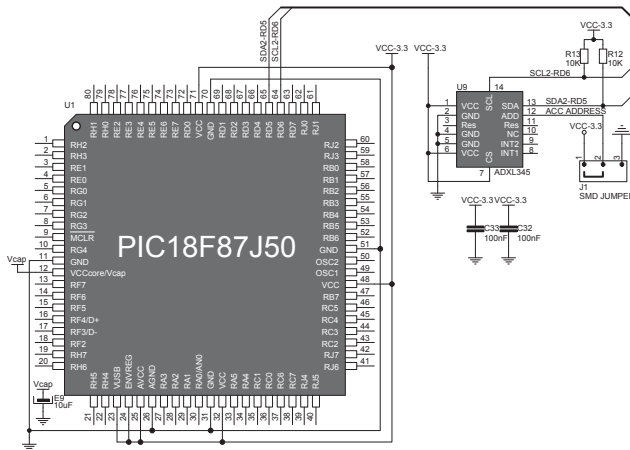

Figure 10-2: Accelerometer connection schematic



You can set the accelerometer address to 0 or 1 by re-soldering the SMD jumper (zero-ohm resistor) to the appropriate position. Jumper is placed in address 1 position by default.

11. Flash Memory

Since multimedia applications are getting increasingly demanding, it is necessary to provide additional memory space to be used for storing more data. The flash memory module enables the microcontroller to use additional **8Mbit** flash memory. It is connected to the microcontroller via the Serial Peripheral Interface (**SPI**).

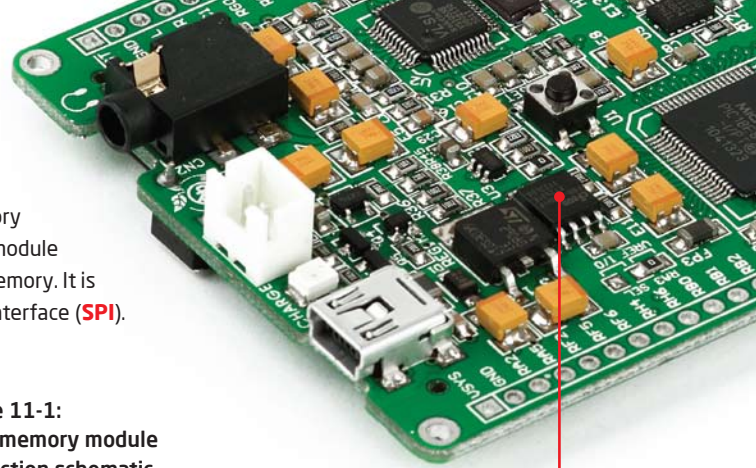

Figure 11-1:
Flash memory module
connection schematic

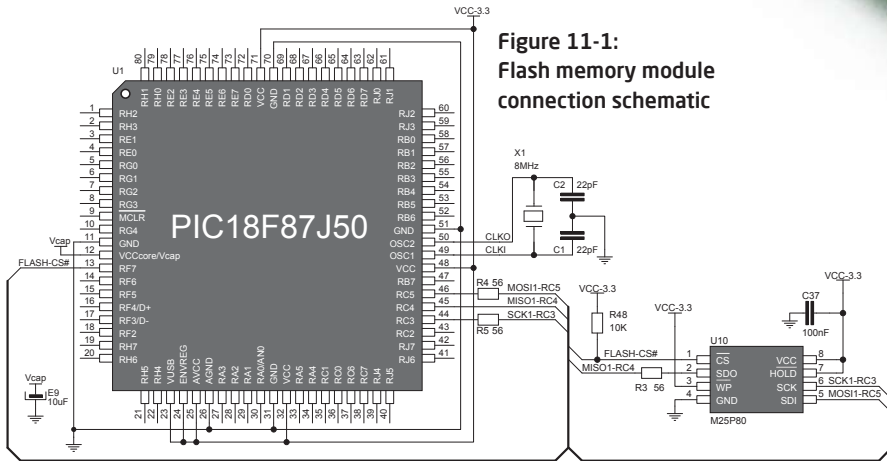

Figure 11-2:
Flash memory module

13. Pinout

- System power supply
- Reference Ground
- AN2/VREF-
- AN4/C2INA
- AN7/C2INB
- AN10/ C1INB/CVREF
- AN11/C1INA
- AN12/P3C/C2INC
- AN14/P1C/C1INC
- FLTO/INT0
- INT1
- INT2
- INT3
- ALE
- OE
- WRL
- WRH
- BAO
- CE
- T10S0/T13CK1
- TOCK1
- SCL1/SCK1
- SDA1/SDI1
- C2OUT/SDO1
- 3.3V power supply
- Reference Ground

- VSYS
- GND
- RA2
- RA5
- RF2
- RF5
- RF6
- RH4
- RH6
- RBO
- RB1
- RB2
- RB3
- RJ0
- RJ1
- RJ2
- RJ3
- RJ4
- RJ5
- RC0
- RA4
- RC3
- RC4
- RC5
- 3.3V
- GND



- RST
- GND
- L
- R
- RC1
- RG0
- RG3
- RG4
- RA3
- RE1
- RE2
- RE3
- RE4
- RE5
- RE6
- RE7
- RB6
- RB7
- RG2
- RG1
- RC7
- RC6
- RD6
- RD5
- 3.3V
- GND

- Reset pin
- Reference Ground
- left ch.] audio out
- right ch.]
- ECCP2/T10SI/P2A
- ECCP3/P3A
- CCP4/P3D
- CCP5/P1D
- AN3/VREF+
- AD9/P2C
- AD10/P2B
- AD11/P3C/REFO
- AD12/P3B
- AD13/P1C
- AD14/P1B
- AD15/P2A
- KB12/PGC
- KB13/PGD
- RX2/DT2
- TX2/CK2
- RX1/DT1
- TX1/CK1
- AD6/SCL2
- AD5/SDA2
- 3.3V power supply
- Reference Ground

--Pin functions--

--Pin functions--

- Programing lines
- Analog Lines
- Interrupt Lines
- SPI Lines
- I2C Lines
- UART lines
- PWM lines
- Comparator lines

14. Dimensions

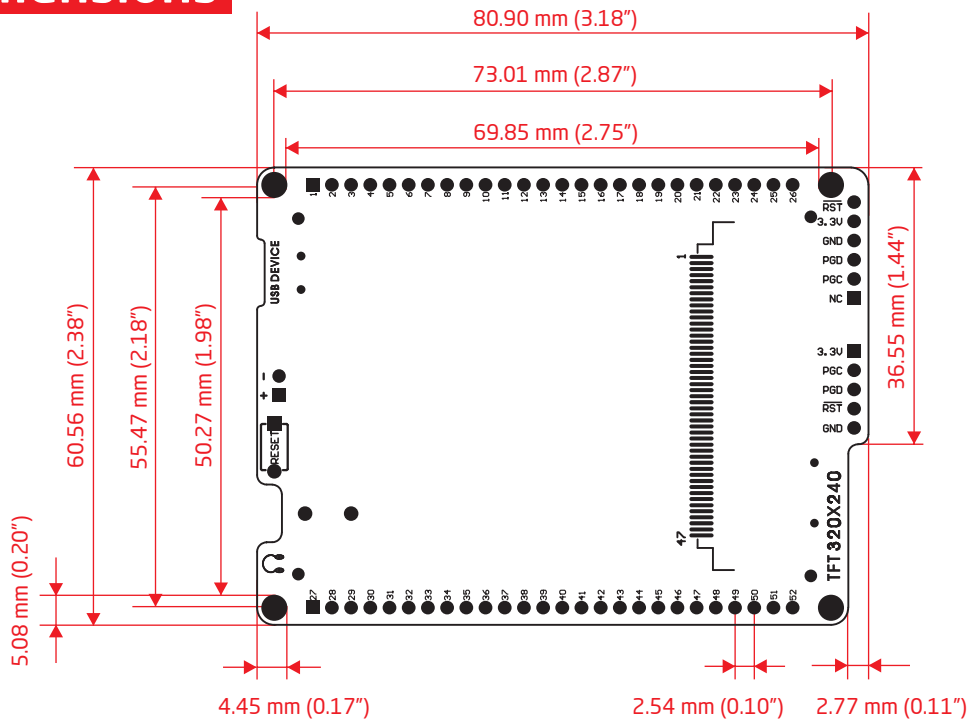

15. mikromedia™ accessories

We have prepared a set of extension boards pin-compatible with your mikromedia™, which enable you to easily expand your board basic functionality. We call them mikromedia shields. But we also offer other accessories, such as Li-polymer battery, stacking headers, wire jumpers and more.



01 Connect shield



02 BatteryBoost shield

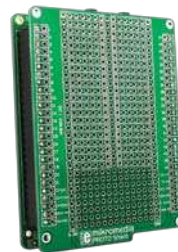

03 PROTO shield



04 Gaming shield



05 Li-Polymer battery



06 Wire Jumpers



07 Stacking headers

What's next?

You have now completed the journey through each and every feature of mikromedia™ for PIC18FJ® board. You got to know its modules and organization. Now you are ready to start using your new board. We are suggesting several steps which are probably the best way to begin. We invite you to join the users of mikromedia™ brand. You will find very useful projects and tutorials and can get help from a large ecosystem of users. Welcome!

Compiler

You still don't have an appropriate compiler? Locate PIC® compiler that suits you best on the Product DVD provided with the package:

DVD://download/eng/software/compilers/

Choose between mikroC™, mikroBasic™ and mikroPascal™ and download fully functional demo version, so you can begin building your first applications.



Projects

Once you have chosen your compiler, and since you already got the board, you are ready to start writing your first projects. **Visual TFT™ software** for rapid development of graphical user interfaces enables you to quickly create your GUI. It will automatically create necessary code which is compatible with mikroElektronika compilers. Visual TFT™ is rich with examples, which are an excellent starting point for your future projects. Just load the example, read well commented code, and see how it works on hardware. Visual TFT™ is also available on the Product DVD.

DISCLAIMER

All the products owned by MikroElektronika are protected by copyright law and international copyright treaty. Therefore, this manual is to be treated as any other copyright material. No part of this manual, including product and software described herein, may be reproduced, stored in a retrieval system, translated or transmitted in any form or by any means, without the prior written permission of MikroElektronika. The manual PDF edition can be printed for private or local use, but not for distribution. Any modification of this manual is prohibited.

MikroElektronika provides this manual 'as is' without warranty of any kind, either expressed or implied, including, but not limited to, the implied warranties or conditions of merchantability or fitness for a particular purpose.

MikroElektronika shall assume no responsibility or liability for any errors, omissions and inaccuracies that may appear in this manual. In no event shall MikroElektronika, its directors, officers, employees or distributors be liable for any indirect, specific, incidental or consequential damages (including damages for loss of business profits and business information, business interruption or any other pecuniary loss) arising out of the use of this manual or product, even if MikroElektronika has been advised of the possibility of such damages. MikroElektronika reserves the right to change information contained in this manual at any time without prior notice, if necessary.

HIGH RISK ACTIVITIES

The products of MikroElektronika are not fault - tolerant nor designed, manufactured or intended for use or resale as on - line control equipment in hazardous environments requiring fail - safe performance, such as in the operation of nuclear facilities, aircraft navigation or communication systems, air traffic control, direct life support machines or weapons systems in which the failure of Software could lead directly to death, personal injury or severe physical or environmental damage ('High Risk Activities'). MikroElektronika and its suppliers specifically disclaim any expressed or implied warranty of fitness for High Risk Activities.

TRADEMARKS

The MikroElektronika name and logo, the MikroElektronika logo, mikroC™, mikroBasic™, mikroPascal™, mikroProg™, EasyPIC™, EasyPIC PRO™, Visual TFT™ and mikromedia™ are trademarks of MikroElektronika. All other trademarks mentioned herein are property of their respective companies.

All other product and corporate names appearing in this manual may or may not be registered trademarks or copyrights of their respective companies, and are only used for identification or explanation and to the owners' benefit, with no intent to infringe.



If you want to learn more about our products, please visit our website at www.mikroe.com

If you are experiencing some problems with any of our products or just need additional information, please place your ticket at www.mikroe.com/esupport

If you have any questions, comments or business proposals,
do not hesitate to contact us at office@mikroe.com

mikromedia for PIC18FJ User Manual
ver. 1.00



0 100000 019443