



HESTORE.HU

elektronikai alkatrész áruház

EN: This Datasheet is presented by the manufacturer.

Please visit our website for pricing and availability at www.hestore.hu.

USB 2.0 to I²C/UART Protocol Converter with GPIO

Note: The MCP2221A is identical to the MCP2221 in all aspects except for the maximum supported baud rate of the UART, which has been increased from 115200 (MCP2221) to 460800 (MCP2221A).

Features:

Universal Serial Bus (USB)

- Supports Full-Speed USB (12 Mb/s)
- Implements USB Protocol Composite Device:
 - Communication Device Class (CDC) for USB-to-UART conversion
 - Human Interface Device (HID) for I²C device control and configuration
- 448-Byte Buffer to Handle Data Throughput at Any Supported UART Baud Rate:
 - 64-byte transmit
 - 384-byte receive
- Human Interface Device (HID) for Both I²C Communication and Control:
 - 64-byte buffer to handle data throughput at any I²C baud rate
- Fully Configurable VID and PID Assignments and String Descriptors
- Bus-Powered or Self-Powered
- USB 2.0-Compliant: TID# 40001594

USB Driver and Software Support

- Enumerates as a Composite USB Device (CDC and HID) Using Standard Drivers for Virtual Com Port (VCP) on the following Windows® Operating Systems: XP® (SP3), Vista®, 7, 8, 8.1 and 10
- Configuration Utility for Establishing a Custom Boot-Up Configuration
- I²C/SMBus Terminal
- Windows DLL

CDC and Universal Asynchronous Receiver/Transmitter (UART) Options

- Communications Device Class (CDC) for the USB-to-UART Option
- Responds to SET LINE CODING Commands to Dynamically Change Baud Rates
- Supports Baud Rates: 300-460800
- UART Tx and Rx Pins Only

- Serial Number Used During the CDC Enumeration Can Be Enabled by Using the Microchip-Provided Configuration Utility or by Calling the Proper API from the Support Libraries for this Device

I²C/SMBus

- The Device Runs as an I²C Master. The Data to Write/Read on the I²C Bus is Conveyed by the USB Interface.
- I²C Master:
 - Up to 400 kHz clock rate
 - Supports 7-bit or 10-bit addressable devices; 10-bit addressable devices are supported through the PC host library
 - Supports block reads/writes of up to 65,535 bytes long
- SMBus Master:
 - Up to 400 kHz clock rate
 - Supports all of the SMBus transfers
 - SMBus functionality is achieved through a combination of chip and support library processing

General Purpose Input/Output (GPIO) Pins

- Four General Purpose Input/Output Pins
- All GP Pins Can Be Assigned to Other Functionalities

Other Functionalities

- UART Activity LED Outputs (UTx and URx)
- SSPND Output Pin
- USBCFG Output Pin (indicates when the Enumeration is Completed)
- Three ADC Inputs
- One DAC with Two Possible Output Options
- Clock Reference Output: 12 MHz or other Configurable Values
- External Interrupt Edge Detection

Other

- Operating Voltage: 3.0 to 5.5V
- Electrostatic Discharge (ESD) Protection: > 4 kV Human Body Model (HBM)
- Industrial (I) Operating Temperature: -40°C to +85°C
- Automotive AEC-Q100 Qualified

MCP2221A

Package Types

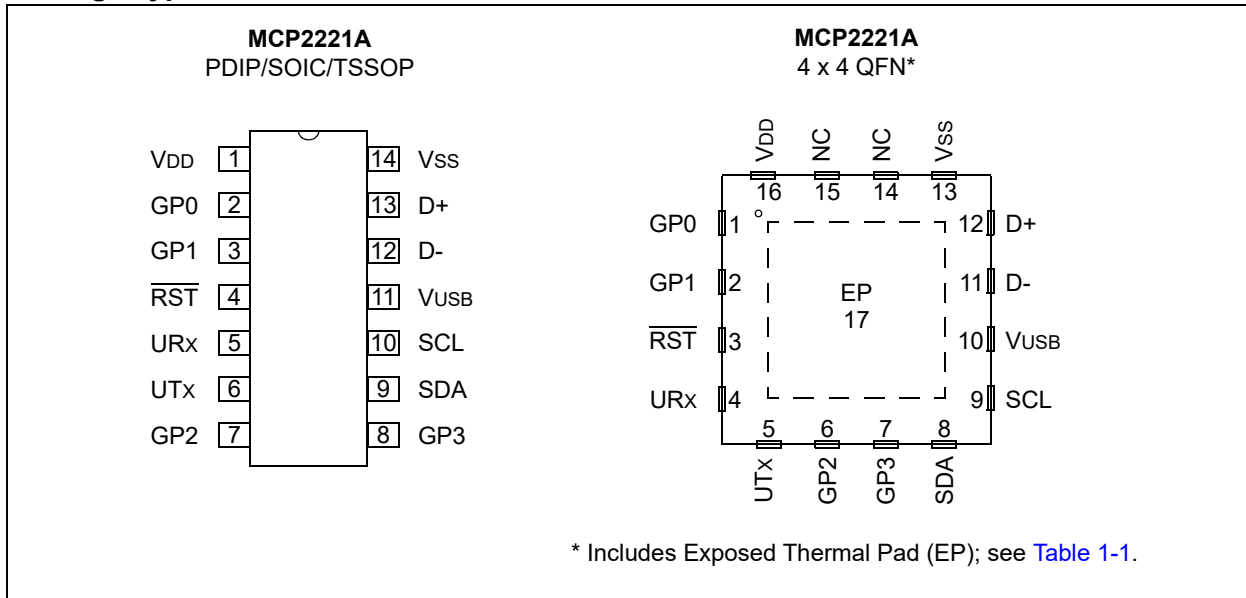

Block Diagram

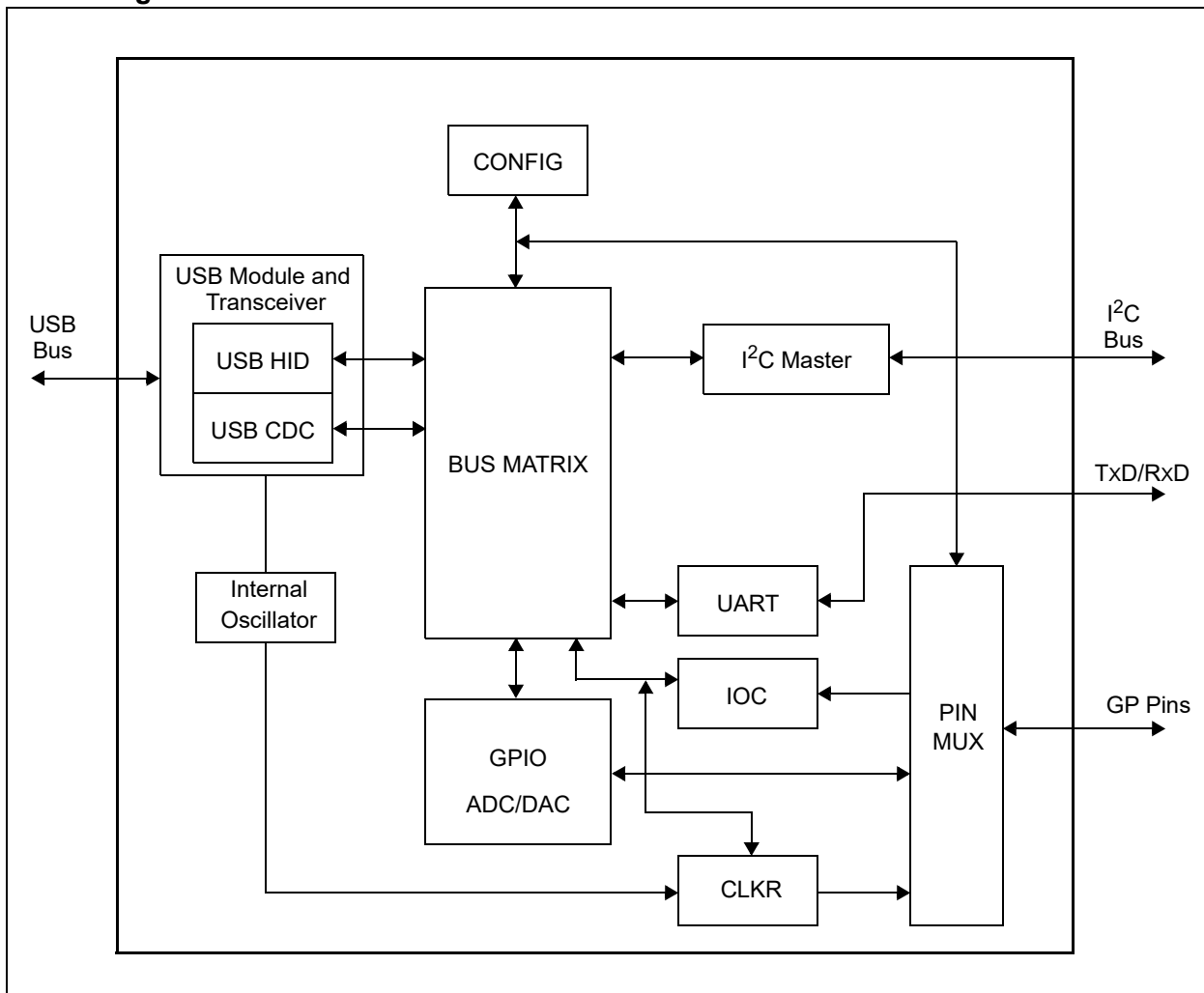

1.0 FUNCTIONAL DESCRIPTION

The MCP2221A is a USB-to-UART serial converter that enables USB connectivity in applications that have UART and/or I²C interfaces. The device reduces external components by integrating the USB termination resistors and the oscillator needed for USB operation.

The MCP2221A has four GP pins for miscellaneous functionalities (including GPIO, USBCFG, SSPND, Clock Output, ADC, DAC and interrupt detector).

See [Table 1-1](#) and [Section 1.7 “Pin MUX Module”](#) for details about the pin functions.

TABLE 1-1: PINOUT DESCRIPTION

Pin Name	PDIP, SOIC,S SOP	QFN	Pin Type	Standard Function	Alternate Functions
GP0	2	1	I/O	General purpose I/O or alternate function pin	<ul style="list-style-type: none"> SSPND (OUT) – Signals when the host has entered Suspend mode LED_URx (OUT) – UART Rx LED activity output (factory default)
GP1	3	2	I/O	General purpose I/O or alternate function pin	<ul style="list-style-type: none"> CLKR (OUT) – Clock Reference Output ADC1 (IN) – ADC Channel 1 LED_UTx (OUT) – UART Tx Led activity output (factory default) IOC (IN) – External interrupt edge detector
RST	4	3	I	Reset input (with internal pull-up)	N/A
URx	5	4	I	UART Rx pin (input)	N/A
UTx	6	5	O	UART Tx pin (output)	N/A
GP2	7	6	I/O	General purpose I/O or alternate function pin	<ul style="list-style-type: none"> USBCFG (OUT) – USB device configured status (factory default) ADC2 (IN) – ADC Channel 2 DAC1 (OUT) – DAC Output 1
GP3	8	7	I/O	General purpose I/O or alternate function pin	<ul style="list-style-type: none"> LED_I2C (OUT) – USB-I²C traffic indicator (factory default) ADC3 (IN) – ADC Channel 3 DAC2 (OUT) – DAC Output 2
SDA	9	8	I/O	I ² C Data line	N/A
SCL	10	9	I/O	I ² C Clock line	N/A
VUSB	11	10	USB	USB Power pin (internally connected to 3.3V); should be locally bypassed with a high-quality ceramic capacitor	—
D-	12	11	USB	USB D-	—
D+	13	12	USB	USB D+	—
Vss	14	13	P	Ground	—
NC	—	14 15	—	Not Connected	—
VDD	1	16	P	Power	—
EP	—	17	—	Exposed Thermal Pad (EP); do not electrically connect	—

MCP2221A

1.1 Supported Operating Systems

The following operating systems are supported:

- Windows – XP (SP3), Vista, 7, 8, 8.1 and 10
- Linux® – any distribution with support for CDC and HID classes
- Mac OS® – all versions – beginning with 10.7

1.1.1 ENUMERATION

The MCP2221A enumerates as a composite USB device after POR. The device enumerates as both a Human Interface Device (HID) for I²C, GPIO control, and as CDC for the USB-to-UART converter.

1.1.1.1 USB HID

The MCP2221A enumerates as an HID, so the device can be configured, while the I²C and GPIO can be controlled. A DLL package, with example applications and tools, is supplied by Microchip on the device web page, on the Microchip website www.microchip.com.

1.1.1.2 USB CDC

The CDC enumeration implements the USB-to-UART data translation.

1.2 Bus Matrix Module

The Bus Matrix module is the heart of the MCP2221A. All other modules are tied together and controlled via the Bus Matrix module. This module manages the data transfers between the USB and the UART, the I²C master module, as well as the command requests generated by the USB host controller and commands for controlling the function of the UART, GPIO, ADC, DAC and clock output.

1.2.1 UART

The control module interfaces to the UART and USB modules.

1.2.2 ACCESSING THE DEVICE

The MCP2221A can be accessed for reading and writing via USB host commands. The device cannot be accessed or controlled via the UART interface.

1.3 UART Interface

The MCP2221A UART interface consists of the Tx and Rx data signals.

The UART is configurable for several baud rates. The available baud rates are listed in [Table 1-2](#).

1.3.1 GET/SET LINE CODING

The `GET_LINE_CODING` and `SET_LINE_CODING` commands are used to read and set the UART parameters while in operation. For example, terminal applications (e.g., Putty, RealTerm, Hyperterminal, etc.) send the `SET_LINE_COMMAND` when connecting to the port. The MCP2221A responds by setting the baud rate only.

The other parameters (Data bits, Parity, Stop bits) remain unchanged.

Note: MCP2221A supports only eight Data bits, no Parity, and one Stop bit.

1.3.1.1 Rounding Errors

Primary baud rate settings (with associated rounding errors) are shown in [Table 1-2](#).

If baud rates other than the ones shown in the table are used, the error percentage can be calculated using [Equation 1-1](#) to find the actual baud rate.

TABLE 1-2: UART PRIMARY BAUD RATES

Desired Rate	Actual rate	% Error
300	300	0.00%
1200	1200	0.00%
2400	2400	0.00%
4800	4800	0.00%
9600	9600	0.00%
19200	19200	0.00%
38400	38339	0.16%
57600	57692	0.16%
115200	115385	0.16%
230400	230769	0.16%
460800	461538	0.16%

EQUATION 1-1: SOLVING FOR ACTUAL BAUD RATE

$$ActualRate = \frac{12MHz}{int(x)}$$

Where:

$$x = \frac{12MHz}{DesiredBaud}$$

1.3.2 CUSTOM BAUD RATES

Custom baud rates are configured by sending the `SET_LINE_CODING` USB command. See [Section 2.0 “USB Enumeration Process”](#) for more information.

1.4 Device Configuration

The MCP2221A keeps all the essential device configuration settings stored in Flash memory.

Device configuration settings affect the way the MCP2221A behaves at run time.

The settings are stored into the Flash memory on the device. Some of the settings are also copied into SRAM at Power-Up/Reset.

These device configuration settings reside in the following two distinct areas of Flash memory:

• Chip Settings

The Chip settings area stores the key MCP2221A parameters – USB parameters, ADC/DAC reference voltage choice, start-up DAC value, Clock Reference output (CLKR) frequency and duty cycle values.

• GP Settings

The GP Settings area stores the GP designation settings. For GP settings that are assigned to GPIO output operation, output values (logic 1 or 0) are also specified.

Even though the MCP2221A places a partial copy of the Chip settings in SRAM, the following Chip settings always reside in Flash:

- USB Manufacturer/Product and Serial Number descriptors
- USB VID and PID pair
- USB options (e.g., the requested amount of current that is presented to the USB host during the USB enumeration process)

1.4.1 POWER-UP/RESET DEVICE CONFIGURATION BEHAVIOR

At Power-up/Reset, the MCP2221A configures the device options (GP designation, special function pins parameters and USB enumeration options) according to the Flash settings. Then, the Flash Chip settings and GP settings are loaded into SRAM to allow for their temporary modification at run time.

Chip settings of the device configuration Flash is copied partially into SRAM. Only the run-time-modifiable parameters are copied into SRAM.

GP Settings of the Device Configuration Flash (GP settings area) are copied entirely into the SRAM. By copying the GP settings completely into SRAM, the user is allowed to completely change the GP designation at run time.

The SRAM copy of the settings can be altered at run time in order to change certain device behavior, e.g., GP designation (the GPs can be re-assigned for a different type of operation than the one assigned at power-up) and special parameters (DAC value, ADC/DAC voltage references, clock output value).

FIGURE 1-1: CHIP SETTINGS RUN TIME MANAGEMENT

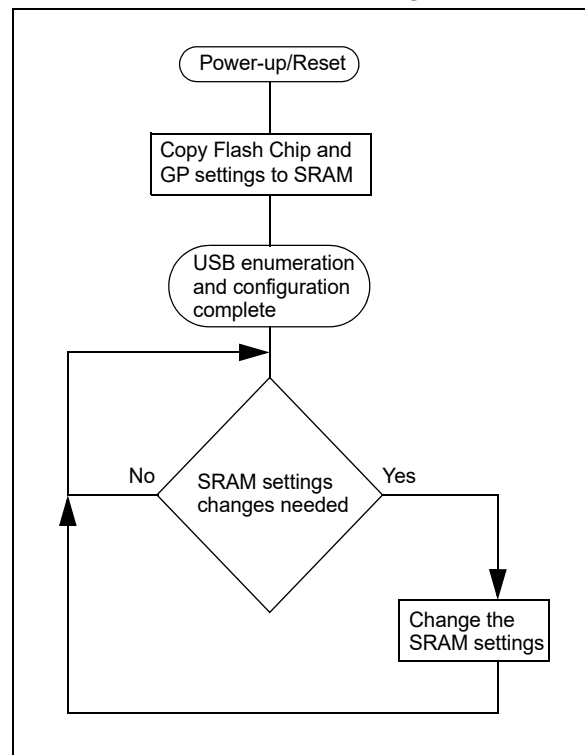

The SRAM settings (GP and partial Chip settings) can be modified through USB HID commands, and they will have an effect on the following device features:

- GP pin designation (switch between GPIO, dedicated or special functions modes)
- GPIO direction and output value (only for GPIO outputs) – for the GPs assigned to work in GPIO mode
- Clock Output duty cycle and value – if GP1 is assigned for CLKR mode (Clock Reference Output mode), by modifying the SRAM settings, the clock frequency and duty cycle can be changed at run time
- DAC value and voltage reference used – the DAC value setting as well as the voltage reference used for it are stored in SRAM settings and they can be changed at run time. Through this mechanism, at run time the user can change the DAC value, as well as the voltage reference.
- ADC voltage reference value – the voltage reference used for ADC conversions can be changed by altering its corresponding SRAM setting
- Interrupt-on-Change (IOC) detector settings – if GP1 is assigned for IOC mode, the SRAM settings are used for setting up the triggers used for external interrupt detection (positive, negative edge detection or both)

MCP2221A

1.4.2 CHIP SETTINGS MAP

The Chip settings area resides in Flash memory and is copied into SRAM at run time. Not all of the device's settings can be altered at run time. All the fields in the Flash settings can be altered by the user.

TABLE 1-3: CHIP SETTINGS MAP

Byte Index	Register Name	Comments
0	CHIPSETTING0	Controls the USB CDC serial number enumeration, default state for the GP LED designation, default state for GP dedicated-function pins and Chip settings protection level
1	CHIPSETTING1	Default clock output divider and duty cycle
2	CHIPSETTING2	DAC reference options and default DAC value
3	CHIPSETTING3	ADC reference and interrupt detection settings
4	USBVIDL	USB VID lower byte
5	USBVIDH	USB VID higher byte
6	USBPIDL	USB PID lower value
7	USBPIDH	USB PID higher byte
8	USBPWRATTR	USB power attributes
9	USBREQCRT	USB required current
10	PASS0	Password byte 0
11	PASS1	Password byte 1
12	PASS2	Password byte 2
13	PASS3	Password byte 3
14	PASS4	Password byte 4
15	PASS5	Password byte 5
16	PASS6	Password byte 6
17	PASS7	Password byte 7

REGISTER 1-1: CHIPSETTING0 REGISTER

R/W-0	R/W-1	R/W-1	R/W-1	R/W-1	R/W-1	R/W-0	R/W-0
CDCSNEN	—	—	—	—	—	CHIPPROT1	CHIPPROT0
bit 7						bit 0	

Legend:

R = Readable bit

W = Writable bit

U = Unimplemented bit, read as '0'

-n = Value at POR

'1' = Bit is set

'0' = Bit is cleared

x = Bit is unknown

- bit 7 **CDCSNEN:** USB CDC Serial Number Enable bit
 1 = USB CDC Serial Number is enumerated
 0 = No USB CDC Serial Number enumeration (factory default)
- bit 6-2 **Reserved:** Set to '1'
- bit 1-0 **CHIPPROT[1:0]:** Chip Settings Protection Level bits
 11 =Reserved
 10 =Permanently locked
 01 =Password protection
 00 =Chip settings unprotected (factory default)

MCP2221A

REGISTER 1-2: CHIPSETTING1 REGISTER

R/W-0	R/W-0	R/W-0	R/W-1	R/W-0	R/W-0	R/W-1	R/W-0
—	—	—	CLKDC1	CLKDC0	CLKDIV2	CLKDIV1	CLKDIV0
bit 7							bit 0

Legend:

R = Readable bit W = Writable bit U = Unimplemented bit, read as '0'
 -n = Value at POR '1' = Bit is set '0' = Bit is cleared x = Bit is unknown

bit 7-5 **Reserved:** Set to '0'

bit 4-3 **CLKDC[1:0]:** Clock-Out Duty-Cycle bits

11 =Duty cycle 75% (75% of 1 clock period is logic '1' and 25% of 1 clock period is logic '0')
 10 =Duty cycle 50% (50% of 1 clock period is logic '1' and 50% of 1 clock period is logic '0')
 (factory default)
 01 =Duty cycle 25% (25% of 1 clock period is logic '1' and 75% of 1 clock period is logic '0')
 00 =Duty cycle 0% (100% of 1 clock period is logic '0')

bit 2-0 **CLKDIV[2:0]:** Clock-Out Divider Output bits

111 =375 kHz clock output
 110 =750 kHz clock output
 101 =1.5 MHz clock output
 100 =3 MHz clock output
 011 =6 MHz clock output
 010 =12 MHz clock output (factory default)
 001 =24 MHz clock output
 000 =Reserved

REGISTER 1-3: CHIPSETTING2 REGISTER

R/W-1	R/W-0	R/W-0	R/W-0	R/W-1	R/W-0	R/W-0	R/W-0
DACVRM1	DACVRM0	DACREF	DACVAL4	DACVAL3	DACVAL2	DACVAL1	DACVAL0
bit 7							bit 0

Legend:

R = Readable bit W = Writable bit U = Unimplemented bit, read as '0'
 -n = Value at POR '1' = Bit is set '0' = Bit is cleared x = Bit is unknown

bit 7-6 **DACVRM[1:0]:** DAC Internal Voltage Reference (DAC VRM) Selection bits

11 =VRM voltage is 4.096V (only if VDD is above this voltage)
 10 =VRM voltage is 2.048V (factory default)
 01 =VRM voltage is 1.024V
 00 =VRM is off

bit 5 **DACREF:** DAC Reference Output Selection bit

1 = DAC reference output is DAC VRM voltage selection
 0 = DAC reference output is VDD (factory default)

bit 4-0 **DACVAL[4:0]:** Initial DAC Output Value bit

5-bit value for the DAC output (factory default is 8 decimal)

REGISTER 1-4: CHIPSETTING3 REGISTER

R/W-0	R/W-1	R/W-1	R/W-0	R/W-1	R/W-1	R/W-0	R/W-0
—	INTDETFEEN	INTDETREEN	ADCVRM1	ADCVRM0	ADCREF	—	—
bit 7							bit 0

Legend:

R = Readable bit W = Writable bit U = Unimplemented bit, read as '0'
 -n = Value at POR '1' = Bit is set '0' = Bit is cleared x = Bit is unknown

- bit 7 **Reserved:** Set to '0'
- bit 6 **INTDETFEEN:** Interrupt Falling Edge Detect Enable bit
 1 = Interrupt detector will trigger when a falling edge is detected (factory default)
 0 = Falling edges will not trigger the detector
- bit 5 **INTDETREEN:** Interrupt Rising Edge Detect Enable bit
 1 = Interrupt detector will trigger when a rising edge is detected (factory default)
 0 = Rising edges will not trigger the detector
- bit 4-3 **ADCVRM[1:0]:** ADC Internal Voltage Reference (ADC VRM) Selection bits
 11 =VRM voltage is 4.096V (only if VDD is above this voltage)
 10 =VRM voltage is 2.048V
 01 =VRM voltage is 1.024V (factory default)
 00 = VRM is off
- bit 2 **ADCREF:** ADC Reference Output Selection bit
 1 = ADC reference output is ADC VRM voltage selection (factory default)
 0 = ADC reference output is VDD
- bit 1-0 **Reserved:** Set to '0'

REGISTER 1-5: USBVIDL REGISTER

R/W-1	R/W-1	R/W-0	R/W-1	R/W-1	R/W-0	R/W-0	R/W-0
USBVIDL7	USBVIDL6	USBVIDL5	USBVIDL4	USBVIDL3	USBVIDL2	USBVIDL1	USBVIDL0
bit 7							bit 0

Legend:

R = Readable bit W = Writable bit U = Unimplemented bit, read as '0'
 -n = Value at POR '1' = Bit is set '0' = Bit is cleared x = Bit is unknown

- bit 7-0 **USBVIDL[7:0]:** USB VID Lower Byte (factory default: 0xD8(hex))

REGISTER 1-6: USBVIDH REGISTER

R/W-0	R/W-0	R/W-0	R/W-0	R/W-0	R/W-1	R/W-0	R/W-0
USBVIDH7	USBVIDH6	USBVIDH5	USBVIDH4	USBVIDH3	USBVIDH2	USBVIDH1	USBVIDH0
bit 7							bit 0

Legend:

R = Readable bit W = Writable bit U = Unimplemented bit, read as '0'
 -n = Value at POR '1' = Bit is set '0' = Bit is cleared x = Bit is unknown

- bit 7-0 **USBVIDH[7:0]:** USB VID Higher Byte (factory default: 0x04(hex))

MCP2221A

REGISTER 1-7: USBPIDL REGISTER

R/W-1	R/W-1	R/W-0	R/W-1	R/W-1	R/W-1	R/W-0	R/W-1
USBPIDL7	USBPIDL6	USBPIDL5	USBPIDL4	USBPIDL3	USBPIDL2	USBPIDL1	USBPIDL0
bit 7							bit 0

Legend:

R = Readable bit W = Writable bit U = Unimplemented bit, read as '0'
-n = Value at POR '1' = Bit is set '0' = Bit is cleared x = Bit is unknown

bit 7-0 **USBPIDL[7:0]:** USB PID Lower Byte (factory default: 0xDD(hex))

REGISTER 1-8: USBPIDH REGISTER

R/W-0	R/W-0	R/W-0	R/W-0	R/W-0	R/W-0	R/W-0	R/W-0
USBPIDH7	USBPIDH6	USBPIDH5	USBPIDH4	USBPIDH3	USBPIDH2	USBPIDH1	USBPIDH0
bit 7							bit 0

Legend:

R = Readable bit W = Writable bit U = Unimplemented bit, read as '0'
-n = Value at POR '1' = Bit is set '0' = Bit is cleared x = Bit is unknown

bit 7-0 **USBPIDH[7:0]:** USB PID Higher Byte (factory default: 0x00(hex))

REGISTER 1-9: USBPWRATTR REGISTER

R/W-0	R/W-0	R/W-0	R/W-0	R/W-0	R/W-0	R/W-0	R/W-0
—	SELPWR	REMWKUP	—	—	—	—	—
bit 7							bit 0

Legend:

R = Readable bit W = Writable bit U = Unimplemented bit, read as '0'
-n = Value at POR '1' = Bit is set '0' = Bit is cleared x = Bit is unknown

bit 7 **Reserved:** Reserved – set to '1' (factory default)

bit 6 **SELPWR:** USB Self-Powered Attribute bit

1 = Chip will enumerate on the USB bus as being self powered

0 = Chip will enumerate on the USB bus as being USB bus powered (factory default)

bit 5 **REMWKUP:** USB Remote Wake-Up Capability bit

1 = Chip will enumerate on the USB bus as being able to wake up the USB host

0 = Chip will enumerate as not being capable of remote wake-up of the USB host (factory default)

bit 4-0 **Reserved:** Set all bits to '0' (factory default)

REGISTER 1-10: USBREQCRT REGISTER

R/W-0	R/W-0	R/W-1	R/W-1	R/W-0	R/W-0	R/W-1	R/W-0
USBRE-QCRT7	USBRE-QCRT6	USBRE-QCRT5	USBRE-QCRT4	USBRE-QCRT3	USBRE-QCRT2	USBRE-QCRT1	USBRE-QCRT0
bit 7							bit 0

Legend:

R = Readable bit W = Writable bit U = Unimplemented bit, read as '0'
-n = Value at POR '1' = Bit is set '0' = Bit is cleared x = Bit is unknown

bit 7-0 **USBREQCRT[7:0]:** USB Bus-Powered Required Current Amount bits (in units of 2 mA)
Factory default is 50 (decimal); the USB enumeration interprets this value as a current requirement of 100 mA.

REGISTER 1-11: PASS0 – PASS7 REGISTER

R/W-0	R/W-0	R/W-0	R/W-0	R/W-0	R/W-0	R/W-0	R/W-0
PASSx7	PASSx6	PASSx5	PASSx4	PASSx3	PASSx2	PASSx1	PASSx0
bit 7							bit 0

Legend:

R = Readable bit W = Writable bit U = Unimplemented bit, read as '0'
-n = Value at POR '1' = Bit is set '0' = Bit is cleared x = Bit is unknown

bit 7-0 **PASSx[7:0]:** Password Byte X Value bits (factory default is 0)

MCP2221A

1.4.3 GP SETTINGS MAP

The GP Settings area resides in Flash memory and is copied into SRAM at run time. The user can alter both the Flash and the SRAM GP settings. Any modification in the SRAM copy of the GP settings will have an immediate effect. The GP pins designation changes according to the new content of the SRAM settings. The Flash variant of the settings will affect the Power-Up behavior of the GP pins.

TABLE 1-4: GP SETTINGS MAP

Byte Index	Register Name	Comments
0	GPSETTING0	GP0 pin designation and GPIO default output value, when GP is set for GPIO output operation
1	GPSETTING1	GP1 pin designation and GPIO default output value, when GP is set for GPIO output operation
2	GPSETTING2	GP2 pin designation and GPIO default output value, when GP is set for GPIO output operation
3	GPSETTING3	GP3 pin designation and GPIO default output value, when GP is set for GPIO output operation

REGISTER 1-12: GPSETTING0 REGISTER

R/W-0	R/W-0	R/W-0	R/W-1	R/W-0	R/W-0	R/W-1	R/W-0
—	—	—	GPIOOUTVAL	GPIODIR	GPDES2	GPDES1	GPDES0
bit 7							bit 0

Legend:

R = Readable bit W = Writable bit U = Unimplemented bit, read as '0'
 -n = Value at POR '1' = Bit is set '0' = Bit is cleared x = Bit is unknown

- bit 7-5 **Reserved:** Set to '0'
- bit 4 **GPIOOUTVAL:** GPIO Output Value bit (valid only when GP0 is set for GPIO output operation)
 - 1 = Default output value is logic '1' (factory default)
 - 0 = Default output value is logic '0'
- bit 3 **GPIODIR:** GPIO Direction bit (input or output; valid only when GP0 is set for GPIO operation)
 - 1 = GPIO Input
 - 0 = GPIO Output (factory default)
- bit 2-0 **GPDES[2:0]:** GP0 Designation bits
 - 111 =Reserved
 - 110 =Reserved
 - 101 =Reserved
 - 100 =Reserved
 - 011 =Reserved
 - 010 =Alternate function 0 (LED UART Rx – LEDURX) (factory default)
 - 001 =Dedicated function operation (SSPND)
 - 000 =GPIO operation (GPIO0)

REGISTER 1-13: GPSETTING1 REGISTER

R/W-0	R/W-0	R/W-0	R/W-1	R/W-0	R/W-0	R/W-1	R/W-1
—	—	—	GPIOOUTVAL	GPDIR	GPDES2	GPDES1	GPDES0
bit 7							bit 0

Legend:

R = Readable bit	W = Writable bit	U = Unimplemented bit, read as '0'
-n = Value at POR	'1' = Bit is set	'0' = Bit is cleared x = Bit is unknown

bit 7-5 **Reserved:** Set to '0'

bit 4 **GPIOOUTVAL:** GPIO Output Value bit (valid only when GP1 is set for GPIO output operation)
 1 = Default output value is logic '1' (factory default)
 0 = Default output value is logic '0'

bit 3 **GPDIR:** GPIO Direction bit (input or output; valid only when GP1 is set for GPIO operation)
 1 = GPIO Input
 0 = GPIO Output (factory default)

bit 2-0 **GPDES[2:0]:** GP1 Designation bits
 111 =Reserved
 110 =Reserved
 101 =Reserved
 100 =Alternate function 2 (Interrupt detector)
 011 =Alternate function 1 (LED UART Tx – LEDUTX) (factory default)
 010 =Alternate function 0 (ADC1)
 001 =Dedicated function operation (Clock Output)
 000 =GPIO operation (GPIO1)

MCP2221A

REGISTER 1-14: GPSETTING2 REGISTER

R/W-0	R/W-0	R/W-0	R/W-1	R/W-0	R/W-0	R/W-0	R/W-1
—	—	—	GPIOOUTVAL	GPDIR	GPDES2	GPDES1	GPDES0
bit 7							bit 0

Legend:

R = Readable bit

W = Writable bit

U = Unimplemented bit, read as '0'

-n = Value at POR

'1' = Bit is set

'0' = Bit is cleared

x = Bit is unknown

bit 7-5 **Reserved:** Set to '0'

bit 4 **GPIOOUTVAL:** GPIO Output Value bit (valid only when GP2 is set for GPIO output operation)

1 = Default output value is logic '1' (factory default)

0 = Default output value is logic '0'

bit 3 **GPDIR:** GPIO Direction bit (input or output; valid only when GP2 is set for GPIO operation)

1 = GPIO Input

0 = GPIO Output (factory default)

bit 2-0 **GPDES[2:0]:** GP2 Designation bits

111 =Reserved

110 =Reserved

101 =Reserved

100 =Reserved

011 =Alternate function 1 (DAC1)

010 =Alternate function 0 (ADC2)

001 =Dedicated function operation (USBCFG) (factory default)

000 =GPIO operation (GPIO2)

REGISTER 1-15: GPSETTING3 REGISTER

R/W-0	R/W-0	R/W-0	R/W-1	R/W-0	R/W-0	R/W-0	R/W-1
—	—	—	GPIOOUTVAL	GPDIR	GPDES2	GPDES1	GPDES0
bit 7							bit 0

Legend:

R = Readable bit

W = Writable bit

U = Unimplemented bit, read as '0'

-n = Value at POR

'1' = Bit is set

'0' = Bit is cleared

x = Bit is unknown

bit 7-5 **Reserved:** Set to '0'

bit 4 **GPIOOUTVAL:** GPIO Output Value bit (valid only when GP3 is set for GPIO output operation)

1 = Default output value is logic '1' (factory default)

0 = Default output value is logic '0'

bit 3 **GPDIR:** GPIO Direction bit (input or output; valid only when GP3 is set for GPIO operation)

1 = GPIO Input

0 = GPIO Output (factory default)

bit 2-0 **GPDES[2:0]:** GP3 Designation bits

111 =Reserved

110 =Reserved

101 =Reserved

100 =Reserved

011 =Alternate function 1 (DAC2)

010 =Alternate function 0 (ADC3)

001 =Dedicated function operation (LED12C) (factory default)

000 =GPIO operation (GPIO3)

MCP2221A

1.5 USB Module (HID, CDC and Transceiver Modules)

The USB HID and CDC modules in the MCP2221A are full-speed USB 2.0-compliant.

- Composite Device (CDC + HID):
 - CDC: USB-to-UART Communications
 - HID: I²C Transactions, GPIO Control, Configuration and Miscellaneous Operations (ADC, DAC, Clock Output)
- 448-byte buffer to handle data throughput at any UART Baud Rate:
 - 64-Byte Transmit
 - 384-Byte Receive
- Fully configurable VID and PID assignments and descriptors (stored on-chip)
- Bus Powered or Self Powered

1.5.1 DESCRIPTORS

During configuration, the supplied PC interface stores the descriptors in the MCP2221A.

1.5.2 SUSPEND AND RESUME

The USB Suspend and Resume signals are supported for power management of the MCP2221A. The device enters Suspend mode when “Suspend Signaling” is detected on the bus.

The MCP2221A exits Suspend mode when any of the following events occur:

- “Resume Signaling” is detected or generated
- A USB “Reset” signal is detected
- A device Reset occurs

1.6 USB Transceiver

The MCP2221A has a built-in USB 2.0 full-speed transceiver internally connected to the USB module.

The USB transceiver obtains power from the V_{USB} pin, which is internally connected to the 3.3V regulator. The best electrical signal quality is obtained when V_{USB} is locally bypassed with a high-quality ceramic capacitor.

1.6.1 INTERNAL PULL-UP RESISTORS

The MCP2221A devices have built-in pull-up resistors designed to meet the requirements for full-speed USB.

1.6.2 MCP2221A POWER OPTIONS

The following are the main power options for the MCP2221A:

- USB Bus Powered (5V)
- 3.3V Self Powered

1.6.2.1 Internal Power Supply Details

MCP2221A offers various options for power supply. To meet the required USB signaling levels, the MCP2221A incorporates an internal LDO that is used solely by the USB transceiver to present the correct D+/D- voltage levels.

Figure 1-2 shows the internal connections of the USB transceiver LDO in relation to the V_{DD} power supply rail. The output of the USB transceiver LDO is tied to the V_{USB} line. A capacitor connected to the V_{USB} pin is required if the USB transceiver LDO provides the 3.3V supply to the transceiver.

FIGURE 1-2: MCP2221A INTERNAL POWER SUPPLY DETAILS

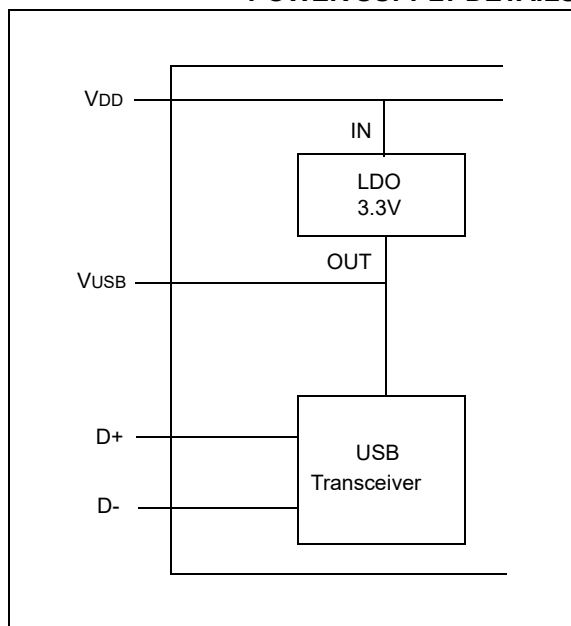

The provided VDD voltage has a direct influence on the voltage levels present on the GPIO and UART Tx/Rx pins. When VDD is 5V, all of these pins will have a logical '1' around 5V with the variations specified in [Section 4.1 "DC Characteristics"](#).

For applications that require a 3.3V logical '1' level, VDD must be connected to a power supply providing the 3.3V voltage. In this case, the internal USB transceiver LDO cannot provide the required 3.3V power. It is necessary to also connect the VUSB pin of the MCP2221A to the 3.3V power supply rail. This way, the USB transceiver is powered up directly from the 3.3V power supply.

1.6.2.2 USB Bus-Powered (5V)

In Bus Power Only mode, all power for the application is drawn from the USB ([Figure 1-3](#)). This is effectively the simplest power method for the device.

FIGURE 1-3: BUS POWER ONLY

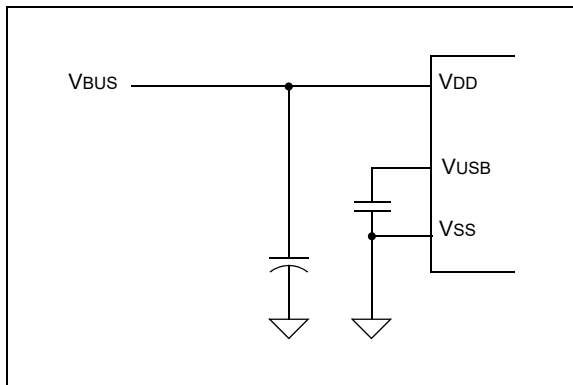

In order to meet the inrush current requirements of the USB 2.0 specifications, the total effective capacitance appearing across VBUS and ground must be no more than 10 μ F. If it is more than 10 μ F, some kind of inrush limiting is required. For more details on Inrush Current Limiting, search for that subject in the latest "*Universal Serial Bus Specification*".

According to the USB 2.0 specification, all USB devices must also support a Low-Power Suspend mode. In the USB Suspend mode, devices must consume no more than 500 μ A (or 2.5 mA for high-powered devices that are remote wake-up capable) from the 5V VBUS line of the USB cable.

The host signals the USB device to enter Suspend mode by stopping all USB traffic to that device for more than 3 ms.

The USB bus provides a 5V voltage. However, the USB transceiver requires 3.3V for the signaling (on D+ and D- lines).

During USB Suspend mode, the D+ or D- pull-up resistor must remain active, which will consume some of the allowed suspend current budget (500 μ A/2.5 mA). The VUSB pin requires an external bypass capacitor with a value between 0.22 and 0.47 μ F (ceramic cap).

[Figure 1-4](#) shows a circuit where MCP2221A's internal LDO is used to provide 3.3V to the USB transceiver. The voltage on the VDD affects the voltage levels onto the UART and GPIO pins. With VDD at 5V, these pins will have a logic '1' of 5V with the variations specified in [Section 4.1 "DC Characteristics"](#).

FIGURE 1-4: TYPICAL POWER SUPPLY OPTION USING THE 5V PROVIDED BY THE USB

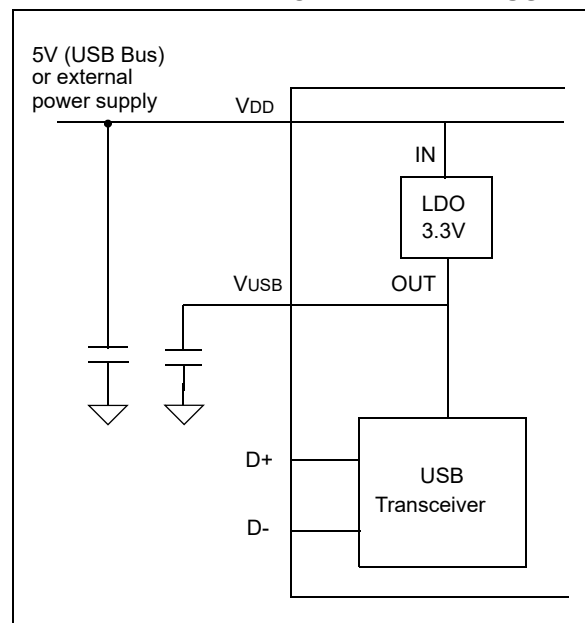

MCP2221A

1.6.2.3 3.3V Self-Powered

Typically, many embedded applications are using 3.3V power supplies. When such option is available in the target system, MCP2221A can be powered up from the existing 3.3V power supply rail. The typical connections for MCP2221A are shown in [Figure 1-5](#).

In this example, MCP2221A has both VDD and VUSB lines tied to the 3.3V rail. These tied connections disable the internal USB transceiver LDO of the MCP2221A to regulate the power supply on the VUSB pin. Another consequence is that the '1' logical level on the GPIO pins will be at the 3.3V level, in accordance with the variations specified in [Section 4.1 "DC Characteristics"](#).

1.6.2.4 Remote Wake-Up Capability

The MCP2221A offers a mechanism for triggering a remote wake-up event for the USB host. The remote wake-up trigger works only with the external interrupt detector.

In order to use this capability, GP1 must be designated for interrupt detection operation. Before the USB host goes into Sleep/Standby, the interrupt detector must be set up for detecting positive edges, negative edges or both; also, the detector flag must be cleared. After these conditions are met, the USB host can go into Sleep/Standby mode and it will be awakened whenever an external signal on GP1 triggers the interrupt detector.

FIGURE 1-5: USING AN EXTERNALLY PROVIDED 3.3V POWER SUPPLY

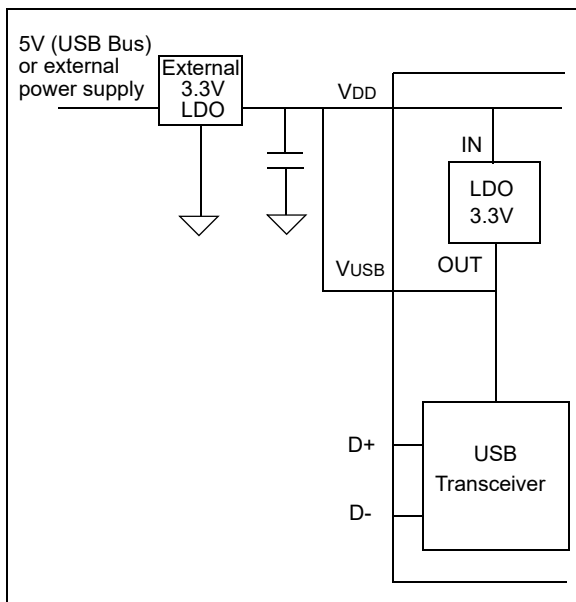

1.7 Pin MUX Module

The pin MUX module offers multiple functionalities for the GP pins.

1.7.1 CONFIGURABLE PIN FUNCTIONS

The pins can be configured as:

- GPIO – individually configurable general purpose input or output
- SSPND – USB Suspend state
- USBCFG – indicates USB configuration status
- LED_URX – indicates UART receive traffic (when seen from the MCP2221A)
- LED_UTX – indicates UART transmit traffic (when seen from the MCP2221A)
- LED_I2C – indicates I²C traffic
- ADC1/2/3 – analog inputs connected to the internal 10-bit ADC
- DAC1/2 – analog outputs connected to the same 5-bit DAC
- CLKR – digital clock output (the nominal value is 12 MHz, but other values are possible)
- IOC – external interrupt detector

1.7.1.1 GPIO Pin Function

When the GPIO pin function is enabled for a given GP(n) pin, it will operate as a digital input or an output pin. When configured as a digital output, its value is controlled through the USB HID commands. When configured as a digital input, its logic value is read using USB HID commands.

1.7.1.2 SSPND Pin Function

The SSPND pin (if enabled) reflects the USB state (Suspend/Resume). The pin is active-low when the Suspend state has been issued by the USB host. Likewise, the pin drives high after the Resume state is achieved.

This pin allows the application to go into Low-Power mode when USB communication is suspended and switches to a full active state when USB activity is resumed.

1.7.1.3 USBCFG Pin Function

The USBCFG pin (if enabled) starts out low during power-up or after Reset and goes high after the device successfully configures to the USB. The pin will go low when in Suspend mode and high when the USB resumes.

1.7.1.4 LED_URX

The “Rx” in this pin name refers to the UART of the MCP2221A. The LED_URX pin is an indicator of UART Rx characters being received.

This pin will pulse low for a period of time (a few milliseconds). This allows the application to provide a visual indication of the UART Rx traffic.

1.7.1.5 LED_UTX

The “Tx” in this pin name refers to the UART of the MCP2221A. The LED_UTX pin is an indicator of UART Tx characters being transmitted.

This pin will pulse low for a period of time (a few milliseconds). This allows the application to provide a visual indication of the UART Tx traffic.

1.7.1.6 LED_I2C

The “I2C” in this pin name refers to the I²C module in the MCP2221A. The LED_I2C pin is an indicator of I²C activity.

This pin will pulse low for a period of time (a few milliseconds). This allows the application to provide a visual indication of the I²C traffic.

1.7.1.7 ADC1/2/3

When GP1/2/3 are configured for ADC operation, they will work as analog input pins and they are tied to the first three channels of the 10-bit ADC in the MCP2221A.

1.7.1.8 DAC1/2

When GP2/3 are configured for DAC operation, they will work as analog output pins and they are tied to the output of the MCP2221A's 5-bit DAC.

TABLE 1-5: GP DESIGNATION TABLE

GP Designation Bits [2:0]	Assignment	GP0	GP1	GP2	GP3
000	GPIO	GPIO	GPIO	GPIO	GPIO
001	DEDICATED_FUNC	SSPND	CLK OUT	USBCFG	LED_I2C
010	ALT_FUNC_0	LED_URX	ADC1	ADC2	ADC3
011	ALT_FUNC_1	—	LED_UTX	DAC1	DAC2
100	ALT_FUNC_2	—	IOC	—	—

MCP2221A

1.8 GPIO/ADC/DAC Module

This module communicates with the USB HID sub-module through the Bus Matrix module. It allows the manipulation of GPIOs, retrieving the ADC data and setting the DAC value.

1.8.1 GPIO

When the GPs are configured for GPIO operation, those configured GPs can be used as digital inputs or outputs.

When working as outputs, the GPs output logic levels (logic 0 or 1).

1.8.1.1 VRM

The ADC and DAC sub-modules each have a voltage reference module (VRM). Each VRM can be configured (at power-up and run time) to output one of the four voltage choices available.

The VRM can provide the following voltages as a reference:

- VDD – the VRM output is exactly the voltage present at the VDD pin of the MCP2221A. It can take any value from 3.3 to 5V.
- 1.024V – the VRM output of 1.024V is obtained from an internal voltage reference
- 2.048V – the VRM output of 2.048V is obtained from an internal voltage reference
- 4.096V – the VRM output of 4.096V is obtained from an internal voltage reference. If the VDD is lower than 4.096V, the VRM output will have the value of VDD.

1.8.2 ADC CONVERTER

The ADC converter is producing 10-bit values and it uses its own VRM module.

It features three external channels (connected to GP1/2/3 if configured for ADC operation).

The sampling rate of the ADC is around 1000 sps.

1.8.3 DAC CONVERTER

The DAC is 5-bit wide, has a single analog output and it uses its own VRM module.

The DAC output voltage can be routed to GP2/3 (if GP2/3 are configured for DAC operation).

If the GP2 and GP3 are configured for DAC operation, they will present the same analog voltage value because they are connected to the same DAC output.

FIGURE 1-7: DAC SUB-MODULE DETAILS

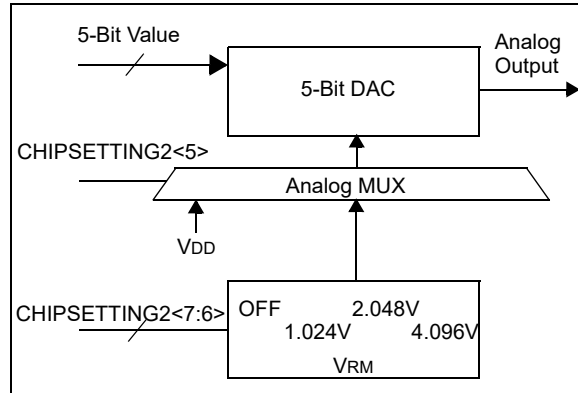
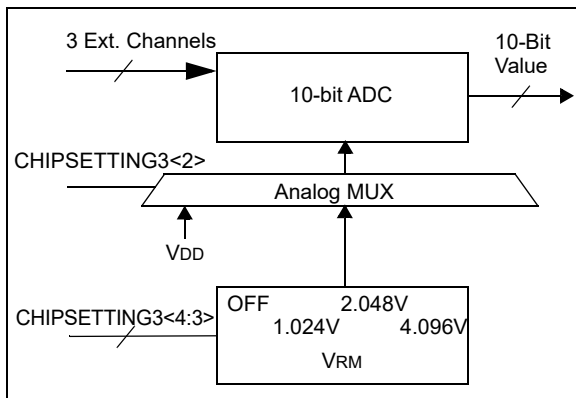

FIGURE 1-6: ADC SUB-MODULE DETAILS



1.9 CLKR

When GP1 is configured for clock output operation, the GP1 pin will act as a digital output, providing a clock signal derived from the device's internal clock. The clock's nominal frequency is 12 MHz \pm 0.25%. Other clock values and duty cycles are possible by setting different values that are associated with this mode of operation.

1.10 IOC

When GP1 is configured for Interrupt-on-Change (IOC) operation, GP1 acts as a digital input that is sensitive to positive and negative edges. Depending on the settings associated with this mode of operation, the GP1 can detect positive, negative or both edges.

1.11 RESET/POR

1.11.1 RESET PIN

The $\overline{\text{RST}}$ pin provides a method for triggering an external Reset of the device. A Reset is generated by holding the pin low. These devices have a noise filter in the Reset path, which detects and ignores small pulses.

1.11.2 POR

A POR pulse is generated on-chip whenever VDD rises above a certain threshold. This allows the device to start in the initialized state when VDD is adequate for operation.

To take advantage of the POR circuitry, tie the $\overline{\text{RST}}$ pin to VDD through a resistor (1 – 10 k Ω). This will eliminate external RC components usually needed to create a POR delay.

In the self-powered configuration, it is recommended to tie the $\overline{\text{RST}}$ pin to the V_{BUS} line of the USB connector, as in Figure 1-8.

FIGURE 1-8: CONNECTING THE $\overline{\text{RST}}$ PIN IN A SELF-POWERED CONFIGURATION (RECOMMENDED)

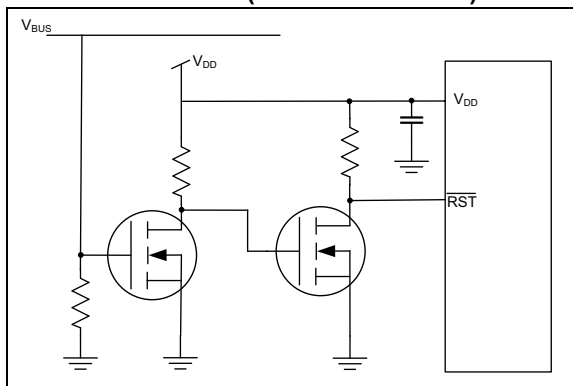

When the device starts normal operation (i.e., exits the Reset condition), device operating parameters (voltage, frequency, temperature, etc.) must be met to ensure operation. If these conditions are not achieved, the device must be held in Reset until the operating conditions are met.

1.12 Internal Oscillator

The MCP2221A features an internal oscillator that provides a 12 MHz clock, which is needed for the USB modules (HID and CDC).

Full-speed USB is nominally 12 Mb/s. The clock signal's accuracy is over temp (2,500 ppm maximum).

The internal clock of the MCP2221A is fed into the CLKR module to provide a clock signal outside of the device.

GP1 can be configured as a clock output pin providing a 12 MHz clock to the rest of the system. Other clock and duty-cycle values are possible by using different settings for this module.

1.13 I²C Master Module

The I²C master module is responsible for the I²C traffic generation. The module is controlled through the USB HID, through the Bus Matrix module.

The I²C module only implements the functionality of an I²C/SMBus master.

1.13.1 I²C/SMBUS MASTER

The I²C master initiates all the I²C/SMBus transactions (being read or write operations) on the bus.

The I²C/SMBus master module has the following capabilities:

- sending/receiving data at a multitude of bit rates, up to 400 kbps
- 7-bit Addressing mode
- single data transfers of up to 65,535 bytes
- clock-stretching (it allows the slower I²C Slaves to communicate)

All the user data to be sent/transmitted over the I²C bus is conveyed to the USB host only through the USB HID interface.

1.14 Bus Matrix Module

The Bus Matrix module manages the communication between various functional modules, such as: USB (HID and CDC), I²C, UART, GPIO/ADC/DAC, Config, IOC, CLKR, pin MUX.

MCP2221A

1.15 Config Module

The Config module is in charge of the storage of the device settings and also of their management (loading/modifying/access protection). The module uses nonvolatile memory for storing the power-up device settings.

At power-up, the module loads the settings from the nonvolatile storage area into an SRAM location (volatile settings). These settings represent the device's configuration, along with other key parameters (e.g., string descriptors, VID/PID, etc.). After the settings are loaded in SRAM (volatile settings), they can be changed through the USB HID interface.

The user can read/modify/change either settings (nonvolatile or volatile) through the same interface (USB HID).

The Config module contains the relevant power-up settings that are used by the MCP2221A. A few examples of settings are USB descriptors, GP settings, ADC, DAC, and CLKR.

2.0 USB ENUMERATION PROCESS

The MCP2221A implements the CDC class to support the USB-to-UART protocol converter functionality. Using USB-to-UART (CDC class) adapters with personal computers running the Windows operating system (OS) requires some consideration because of the way the Windows OS responds to their connection.

When a USB-to-UART (CDC class) adapter is connected to the USB port of the PC, Windows searches for a driver. After a suitable driver is found, the system creates an entry in the registry. The entry stores relevant information about the USB-to-UART adapter, its driver and the associated COM port.

The COM port and its number are legacy-type adapters, which are still supported by Windows OS. Historically, the COM ports in a computer are part of the computer's motherboard and are assigned a different index number. With the advent of USB-to-UART adapters, the Windows OS kept the COM port concept and extended it to support the USB adapters.

Whenever a USB-to-UART adapter is first connected to a PC, the system searches the registry for an entry that is suitable for the connected adapter. If one is not found, the system asks for a suitable driver. If this step is completed, it creates a registry entry, and assigns a COM port number as well. Then, whenever the USB-to-UART adapter is connected to that PC, the system checks the registry entry, loads the specified driver and assigns the given COM port number (as found in the registry entry).

During the enumeration process, the device can specify a serial number. If it does, this number is stored in the registry entry and it is used to assign the same COM port number to the adapter in question, no matter which USB port the adapter is connected to.

USB-to-UART adapters have the option to not present a serial number during USB enumeration. In this case, the operating system would not be able to differentiate between two identical devices, if neither is providing its serial number. Each time one of these two devices (with no serial number provided during enumeration) is connected to the same USB port, they will have the same COM port number assigned.

Both functionalities (with or without serial numbers) are very useful for different applications.

When the serial number is provided, an adapter using the MCP2221A solution receives the same COM port number from a Windows machine, no matter which USB port they are connected to.

The case with no serial number is useful for test/validation of products using the MCP2221A. The fact that all the tested boards are not supplying a serial number will force Windows to assign them the same COM port number (but only if connected to the same USB port).

The MCP2221A is factory-set to not use a serial number. Later in the process, if a customer wants the benefits provided by using a serial number, the Configuration Utility from Microchip can be used to enable the MCP2221A to enumerate its serial number as well.

The MCP2221A comes with a uniquely-provided serial number to be used during the USB enumeration process; however, this can be changed by the user in the Configuration Utility.

The serial number enumeration enable/disable can be changed, as well, using the Configuration Utility.

All the USB-related settings mentioned above are part of the Device Configuration (Chip settings area) and they reside only in Flash. When the Chip settings area (1st area) is being copied into the SRAM (at power-up), the USB settings are skipped (not copied into SRAM).

MCP2221A

3.0 USB HID COMMUNICATION

Except for the USB CDC and UART modules, all the other modules in the MCP2221A use USB HID protocol for communication.

The USB HID protocol uses 64-byte reports.

A typical command exchange starts with a 64-byte packet that is written by the USB host (i.e., the PC). Afterward, the USB host reads the response from the device as a 64-byte packet.

3.1 USB HID Commands/Responses

3.1.1 STATUS/SET PARAMETERS

This command offers many options for this device. It is used to poll for the status of the device. It is also used to establish certain I²C bus parameters/conditions.

TABLE 3-1: COMMAND STRUCTURE

Byte Index	Function Description	Value	Effect
0	—	0x10	Status/Set Parameters – command code
1	Don't care	Any value	—
2	Cancel current I ² C/SMBus transfer (sub-command)	0x10	When this value is put in this field, the device will cancel the current I ² C/SMBus transfer and will attempt to free the I ² C bus. This command is very useful since it can cancel a transfer and free the bus. An example would be when trying to communicate with a device using a wrong address. This will cause a timeout to occur. This time-out situation can be read using the “Status/Set Parameter” and the cancellation of the I ² C/SMBus transfer can be achieved by this sub-command.
		Any other value	No effect.
3	Set I ² C/SMBus communication speed (sub-command)	0x20	When this value is put in this field, the device will take the next command field and interpret it as the system clock divider that will give the I ² C/SMBus communication clock.
		Any other value	No effect.
4	The I ² C/SMBus system clock divider that will be used to establish the communication speed	—	The value in this field is being taken into consideration only when the Byte Index 3 contains the code for establishing a new communication speed. In all the other cases, this field's value will not matter.
5-63	Don't care	Any value	—

3.1.1.1 Responses

TABLE 3-2: RESPONSE 1 STRUCTURE

Byte Index	Function Description	Value	Effect
0	—	0x10	Status/Set Parameters – command code echo
1	—	0x00	Command completed successfully
2	Cancel transfer	0x00	No special operation (i.e., Cancel current I ² C/SMBus transfer)
		0x10	The current I ² C/SMBus transfer was marked for cancellation. The actual I ² C/SMBus transfer cancellation and bus release will need some time (a few hundreds of microseconds, depending on the communication speed initially chosen for the canceled transfer)
		0x11	The I ² C engine (inside MCP2221A) was already in Idle mode. The cancellation command had no effect.
3	—	0x00	No Set I ² C/SMBus communication speed was issued.
		0x20	The new I ² C/SMBus communication speed is now considered.
		0x21	The I ² C/SMBus communication speed was not set (e.g., I ² C transfer in progress).
4	—	The divider value given at the same index in the command field	Only in the case when the code for establishing a new communication speed is given at Byte Index 3.
		0x00	When the communication speed is not being set.
5-8	Don't care	Any value	—
9	Lower byte (16-bit value) of the requested I ² C transfer length	—	—
10	Higher byte (16-bit value) of the requested I ² C transfer length	—	—
11	Lower byte (16-bit value) of the already transferred (through I ² C) number of bytes	—	—
12	Higher byte (16-bit value) of the already transferred (through I ² C) number of bytes	—	—
13	Internal I ² C data buffer counter	—	—
14	Current I ² C communication speed divider value	—	—
15	Current I ² C time-out value	—	—
16	Lower byte (16-bit value) of the I ² C address being used	—	—
17	Higher byte (16-bit value) of the I ² C address being used	—	—
18-21	Don't care	Any value	—
22	SCL line value – as read from the pin	—	—

MCP2221A

TABLE 3-2: RESPONSE 1 STRUCTURE (CONTINUED)

Byte Index	Function Description	Value	Effect
23	SDA line value – as read from the pin	—	—
24	Interrupt edge detector state	0 or 1	—
25	I ² C Read pending value	0, 1 or 2	This field is used by the USB host to know if the MCP2221A still has to read from a slave device.
26-45	Don't care	Any value	—
46	MCP2221A Hardware Revision Major ('A')	—	—
47	MCP2221A Hardware Revision Minor ('6')	—	—
48	MCP2221A Firmware Revision Major ('1')	—	—
49	MCP2221A Firmware Revision Minor ('1')	—	—
50-55	ADC Data (16-bit) values.	—	3 x (16-bit) little-endian ADC channel values (CH0 LSB, CH0 MSB, CH1 LSB, CH1 MSB, CH2 LSB, CH2 MSB).
56-63	Don't care	Any value	—

3.1.2 READ FLASH DATA

This command is used to read various important data structures and strings that are stored in Flash memory on the MCP2221A.

TABLE 3-3: COMMAND STRUCTURE

Byte Index	Function Description	Value	Effect
0	—	0xB0	Read Flash Data – command code
1	Read Flash Data Sub-code. The value in this field will instruct the MCP2221A on what Flash data to be read.	0x00	Read Chip Settings – reads the MCP2221A Flash settings
		0x01	Read GP Settings – reads the MCP2221A Flash GP settings
		0x02	Read USB Manufacturer Descriptor String – reads the USB Manufacturer String Descriptor used during the USB enumeration
		0x03	Read USB Product Descriptor String – reads the USB Product String Descriptor used during the USB enumeration
		0x04	Read USB Serial Number Descriptor String – reads the USB Serial Number String Descriptor that is used during USB enumeration. This serial number can be changed by the user through a specific USB HID command.
		0x05	Read Chip Factory Serial Number – reads the factory-set serial number. This serial number cannot be changed.
	Any other value		No meaning. The device will reply with a code for an unsupported command at Byte Index 1 in the Response report.
2-63	Reserved	0x00	—

3.1.2.1 Responses

TABLE 3-4: RESPONSE STRUCTURE

Byte Index	Function Description	Value	Effect
0	—	0xB0	Read Flash Data – command code
1	—	0x00	Command completed successfully
		0x01	Command not supported
2	Data structure length or Don't care	—	—
3-63	Data or Don't care	—	Depends on the issued sub-command or the returned code at Byte Index 1

MCP2221A

TABLE 3-5: RESPONSE STRUCTURE – READ CHIP SETTINGS SUB-COMMAND

Byte Index	Function Description	Value	Effect
0	—	0xB0	Read Flash Data – command code echo
1	—	0x00	Command completed successfully
2	Structure length	—	—
3	Don't care	—	—
4	Bit 7: CDC Serial Number Enumeration Enable	1	The USB serial number will be used during the USB enumeration of the CDC interface.
		0	No serial number descriptor will be presented during the USB enumeration.
	Bit 6: Initial value for LEDUARTRX pin option	—	This value represents the logic level signaled when no UART Rx activity takes places. When the UART Rx (of the MCP2221A) is receiving data, the LEDUARTRX pin will take the negated value of this bit.
	Bit 5: Initial value for LEDUARTTX pin option	—	This value represents the logic level signaled when no UART Tx transmission takes place. When the UART Tx (of the MCP2221A) is sending data, the LEDUARTTX pin will take the negated value of this bit.
	Bit 4: Initial value for LEDI2C pin option	—	This value represents the logic level signaled when no I ² C traffic occurs. When the I ² C traffic is active, the LEDI2C pin (if enabled) will take the negated value of this bit.
	Bit 3: Initial value for SSPND pin option	—	This value represents the logic level signaled when the device is not in Suspend mode. Upon entering Suspend mode, the SSPND pin (if enabled) will take the negated value of this bit.
	Bit 2: Initial value for USBCFG pin option	—	This value represents the logic level signaled when the device is not USB configured. When the device will be USB configured, the USBCFG pin (if enabled) will take the negated value of this bit.
	Bits 1-0: Chip Configuration security option	11-10	Permanently locked
01		Password-protected	
00		Unsecured	
5	Bits 7-5	Don't care	—
	Bits 4-0: Clock Output divider value	—	If the GP pin (exposing the clock output) is enabled for clock output operation, the divider value will be used on the 48 MHz USB internal clock and its divided output will be sent to this pin.
6	Bits 7-6: DAC Reference voltage option	11	Reference voltage is 4.096V (only if VDD is above this voltage)
		10	Reference voltage is 2.048V
		01	Reference voltage is 1.024V
		00	Reference voltage is off (this is useful for the case in which the DAC uses other reference than VRM DAC; e.g., VDD)
	Bit 5: DAC reference option	1	DAC reference is VRM DAC voltage
		0	DAC reference is VDD
Bits 4-0: Power-up DAC value	—	—	

TABLE 3-5: RESPONSE STRUCTURE – READ CHIP SETTINGS SUB-COMMAND (CONTINUED)

Byte Index	Function Description	Value	Effect
7	Bit 7	Don't care	—
	Bit 6: Interrupt detection – negative edge	—	If set, the interrupt detection flag will be set when a negative edge occurs.
	Bit 5: Interrupt detection – positive edge	—	If set, the interrupt detection flag will be set when a positive edge occurs.
	Bit 4-3: ADC Reference Voltage	11	Reference voltage is 4.096V (only if VDD is above this voltage)
		10	Reference voltage is 2.048V
		01	Reference voltage is 1.024V
		00	Reference voltage is off (this is useful for the case in which the ADC uses other reference than VRM ADC; e.g., VDD)
	Bit 2	1	DAC reference is VDD DAC voltage
		0	DAC reference is VRM
Bit 1	Don't care	—	
Bit 0	Don't care	—	
8	Lower byte of the 16-bit USB VID value	—	—
9	Higher byte of the 16-bit USB VID value	—	—
10	Lower byte of the 16-bit USB PID value	—	—
11	Higher byte of the 16-bit USB PID value	—	—
12	USB power attributes ⁽¹⁾	—	This value will be used by the MCP2221A's USB Configuration Descriptor (power attributes value) during the USB enumeration.
13	USB requested number of mA(s) ⁽¹⁾	—	The requested mA value during the USB enumeration will represent the value at this index multiplied by 2.
14-63	Don't care	—	—

Note 1: Please consult the USB 2.0 specification for details on the correct values for power and attributes.

MCP2221A

TABLE 3-6: RESPONSE STRUCTURE – READ GP SETTINGS SUB-COMMAND

Byte Index	Function Description	Value	Effect
0	—	0xB0	Read Flash Data – command code echo
1	—	0x00	Command completed successfully
2	—		Structure length
3	—	Don't care	—
4	GP0 Power-Up Settings		
	Bit 7-5:	Don't care	—
	Bit 4: GPIO Output value	—	When GP0 is set as an output GPIO, this value will be present at the GP0 pin at Power-up/Reset.
	Bit 3: GPIO Direction (Input/Output) – Works only when GP0 is set for GPIO operation	1	GPIO Input mode
		0	GPIO Output mode
	Bit 2-0: GP0 Designation	111-011	Don't care
		010	Alternate function 0 (LED UART RX)
001		Dedicated function operation (SSPND)	
000		GPIO operation	
5	GP1 Power-Up Settings		
	Bits7-5:	Don't care	—
	Bit 4: GPIO Output value	—	When GP1 is set as an output GPIO, this value will be present at the GP1 pin at Power-up/Reset.
	Bit 3: GPIO Direction (Input/Output) – Works only when GP0 is set for GPIO operation	1	GPIO Input mode
		0	GPIO Output mode
	Bit 2-0: GP1 Designation	111-101	Don't care
		001	Dedicated function operation (Clock Output)
		100	Alternate function 2 (Interrupt Detection)
		011	Alternate function 1 (LED UART TX)
		010	Alternate function 0 (ADC1)
000		GPIO operation	
6	GP2 Power-Up Settings		
	Bits7-5:	Don't care	—
	Bit 4: GPIO Output value	—	When GP2 is set as an output GPIO, this value will be present at the GP2 pin at Power-up/Reset.
	Bit 3: GPIO Direction (Input/Output) – Works only when GP2 is set for GPIO operation	1	GPIO Input mode
		0	GPIO Output mode
	Bit 2-0: GP1 Designation	111-100	Don't care
		011	Alternate function 1 (DAC1)
		010	Alternate function 0 (ADC2)
		001	Dedicated function operation (USB)
000		GPIO operation	

TABLE 3-6: RESPONSE STRUCTURE – READ GP SETTINGS SUB-COMMAND (CONTINUED)

Byte Index	Function Description	Value	Effect
7	GP3 Power-Up Settings		
	Bits7-5:	Don't care	—
	Bit 4: GPIO Output value	—	When GP3 is set as an output GPIO, this value will be present at the GP3 pin at Power-up/Reset.
	Bit 3: GPIO Direction (Input/Output) – Works only when GP3 is set for GPIO operation	1	GPIO Input mode
		0	GPIO Output mode
	Bit 2-0: GP1 Designation	111-100	Don't care
		011	Alternate function 1 (DAC2)
		010	Alternate function 0 (ADC3)
001		Dedicated function operation (LED I2C)	
	000	GPIO operation	
8-63	—	Don't care	—

TABLE 3-7: RESPONSE STRUCTURE – READ USB MANUFACTURER DESCRIPTOR STRING SUB-COMMAND

Byte Index	Value	Effect
0	0xB0	Read Flash Data – command code echo
1	0x00	Command completed successfully
2	(2)	Number of bytes + 2 in the provided USB Manufacturer Descriptor String. The actual string starts at Byte Index 4.
3	0x03	The value at this index must always be 0x03.
$4 + 2 \times \text{Unicode_char_number} + 0^{(1)}$	—	Lower byte of the 16-bit Unicode character.
$4 + 2 \times \text{Unicode_char_number} + 1^{(1)}$	—	Higher byte of the 16-bit Unicode character.
$(4 + 2 \times \text{Unicode_char_number} + 2) - 63^{(1)}$	—	Don't care. Only if the USB String Descriptor is less than 60-bytes long in total.

Note 1: “Unicode_char_number” value starts from 0 to a maximum of 30 (included).

2: The value at Byte Index 2 must be $2 + 2 \times (\text{number of Unicode characters in the string})$.

TABLE 3-8: RESPONSE STRUCTURE – READ USB PRODUCT DESCRIPTOR STRING SUB-COMMAND

Byte Index	Value	Effect
0	0xB0	Read Flash Data – command code echo
1	0x00	Command completed successfully
2	(2)	Number of bytes + 2 in the provided USB Product Descriptor String. The actual string starts at Byte Index 4.
3	0x03	The value at this index must always be 0x03.
$4 + 2 \times \text{Unicode_char_number} + 0^{(1)}$	—	Lower byte of the 16-bit Unicode character.
$4 + 2 \times \text{Unicode_char_number} + 1^{(1)}$	—	Higher byte of the 16-bit Unicode character.
$(4 + 2 \times \text{Unicode_char_number} + 2) - 63^{(1)}$	—	Don't care. Only if the USB String Descriptor is less than 60-bytes long (in total).

Note 1: “Unicode_char_number” value starts from 0 to a maximum of 30 (included).

2: The value at Byte Index 2 must be $2 + 2 \times (\text{number of Unicode characters in the string})$.

MCP2221A

TABLE 3-9: RESPONSE STRUCTURE – READ USB SERIAL NUMBER DESCRIPTOR STRING SUB-COMMAND

Byte Index	Value	Effect
0	0xB0	Read Flash Data – command code echo
1	0x00	Command completed successfully
2	(2)	The number of bytes + 2 in the provided USB Serial Number Descriptor String. The actual string starts at Byte Index 4.
3	0x03	The value at this index must always be 0x03.
4 + 2 x Unicode_char_number + 0 ⁽¹⁾	—	Lower byte of the 16-bit Unicode character
4 + 2 x Unicode_char_number + 1 ⁽¹⁾	—	Higher byte of the 16-bit Unicode character
(4 + 2 x Unicode_char_number + 2) - 63 ⁽¹⁾	—	Don't care. Only if the USB String Descriptor is less than 60-bytes long in total.

Note 1: “Unicode_char_number” value starts from 0 to a maximum of 30 (included).

2: The value at Byte Index 2 must be 2 + 2 x (number of Unicode characters in the string).

TABLE 3-10: RESPONSE STRUCTURE – READ CHIP FACTORY SERIAL NUMBER SUB-COMMAND⁽¹⁾

Byte Index	Value	Effect
0	0xB0	Read Flash Data – command code echo
1	0x00	Command completed successfully
2	—	Structure length
3	Don't care	—
4 - (4 + Structure length - 1)	—	Structure data – Factory Serial Number String
(4 + Structure length) - 63	Don't care	—

Note 1: The Chip Serial Number is typically 8 bytes in length.

3.1.3 WRITE FLASH DATA

This command is used to write various important data structures and strings into the Flash memory of the device.

TABLE 3-11: COMMAND STRUCTURE

Byte Index	Function Description	Value	Effect
0	—	0xB1	Write Flash Data – command code
1	Write Flash Data Sub-code. The value in this field will instruct the MCP2221A about the particular Flash settings to be altered.	0x00	Write Chip Settings – writes the MCP2221A Flash settings
		0x01	Write GP Settings – writes the MCP2221A Flash GP settings
		0x02	Write USB Manufacturer Descriptor String – writes the USB Manufacturer String Descriptor used during the USB enumeration
		0x03	Write USB Product Descriptor String – writes the USB Product String Descriptor used during the USB enumeration
		0x04	Write USB Serial Number Descriptor String – writes the USB Serial Number String Descriptor used during the USB enumeration
		Any other value	No meaning. The device will reply with a code for an unsupported command at Byte Index 1 in the response report.
2-63	Data to be written	—	Data format depends on the Write Flash Data Sub-code (at Byte Index 1).

MCP2221A

TABLE 3-12: SUB-COMMAND STRUCTURE – WRITE CHIP SETTINGS SUB-COMMAND

Byte Index	Function Description	Value	Effect
0	—	0xB1	Write Flash Data – command code
1	—	0x00	Write Chip Settings – writes the MCP2221A Flash device settings
2	Bit 7: CDC Serial Number Enumeration Enable	1	The USB serial number will be used during the USB enumeration of the CDC interface.
		0	No serial number descriptor will be presented during the USB enumeration.
	Bit 6: Initial value for LEDUARTRX pin option	—	This value represents the logic level signaled when no UART RX activity takes places. When the UART RX (of the MCP2221A) is receiving data, the LEDUARTRX pin will take the negated value of this bit.
	Bit 5: Initial value for LEDUARTTX pin option	—	This value represents the logic level signaled when no UART TX transmission takes place. When the UART TX (of the MCP2221A) is sending data, the LEDUARTTX pin will take the negated value of this bit.
	Bit 4: Initial value for LEDI2C pin option	—	This value represents the logic level signaled when no I ² C traffic occurs. When I ² C traffic is active, the LEDI2C pin (if enabled) will take the negated value of this bit.
	Bit 3: Initial value for SSPND pin option	—	This value represents the logic level signaled when the device is not in Suspend mode. Upon entering Suspend mode, the SSPND pin (if enabled) will take the negated value of this bit.
	Bit 2: Initial value for USBCFG pin option	—	This value represents the logic level signaled when the device is not USB configured. When the device will be USB-configured, the USBCFG pin (if enabled) will take the negated value of this bit.
	Bit 1-0: Chip Configuration security option	11-10	Permanently locked
		01	Password-protected
00		Unsecured	
3	Bit 7-5	Don't care	—
	Bit 4-0: Clock Output divider value	—	If the GP pin (exposing the clock output) is enabled for clock output operation, the divider value will be used on the 48 MHz USB internal clock and its divided output will be sent to this pin.
4	Bit 7-6: DAC Reference voltage option	11	Reference voltage is 4.096V (only if VDD is above this voltage)
		10	Reference voltage is 2.048V
		01	Reference voltage is 1.024V
		00	Reference voltage is off (this is useful for the case in which the DAC uses other reference than VRM DAC, i.e., VDD)
	Bit 5: DAC reference option	1	DAC reference is VDD
		0	DAC reference is VRM DAC voltage
Bit 4-0: Power-up DAC value	—	—	

TABLE 3-12: SUB-COMMAND STRUCTURE – WRITE CHIP SETTINGS SUB-COMMAND

Byte Index	Function Description	Value	Effect
5	Bit 7	Don't care	—
	Bit 6: Interrupt detection – negative edge	—	If set, the interrupt detection flag will be set when a negative edge occurs.
	Bit 5: Interrupt detection – positive edge	—	If set, the interrupt detection flag will be set when a positive edge occurs.
	Bit 4-3: ADC Reference Voltage	11	Reference voltage is 4.096V (only if VDD is above this voltage).
		10	Reference voltage is 2.048V
		01	Reference voltage is 1.024V
		00	Reference voltage is off (this is useful for the case in which the ADC uses other reference than VRM ADC; e.g., VDD)
	Bit 2: ADC Reference Option	1	ADC reference voltage is VRM ADC
		0	ADC reference voltage is VDD
Bit 1	Don't care	—	
Bit 0	Don't care	—	
6	Lower byte of the 16-bit USB VID value.	—	—
7	Higher byte of the 16-bit USB VID value.	—	—
8	Lower byte of the 16-bit USB PID value.	—	—
9	Higher byte of the 16-bit USB PID value.	—	—
10	USB power attributes	—	This value will be used by the MCP2221A's USB Configuration Descriptor (power attributes value) during the USB enumeration.
11	USB requested number of mA(s)	—	The requested mA value during the USB enumeration will represent the value at this index multiplied by 2.
12-19	8-bytes password (for Flash modifications protection)	—	—
20-63	—	Don't care	—

MCP2221A

TABLE 3-13: SUB-COMMAND STRUCTURE – WRITE GP SETTINGS SUB-COMMAND

Byte Index	Function Description	Value	Effect
0	—	0xB1	Write Flash Data – command code
1	—	0x01	Write GP Settings – it will write the MCP2221A Flash GP settings
2	GP0 Power-Up Settings		
	Bit 7-5:	Don't care	—
	Bit 4: GPIO Output value	—	When GP0 is set as an output GPIO, this value will be present at the GP0 pin at Power-up/Reset.
	Bit 3: GPIO Direction (Input/Output) – Works only when GP0 is set for GPIO operation.	1	GPIO Input mode
		0	GPIO Output mode
	Bit 2-0: GP0 Designation	111-011	Don't care
		010	Dedicated function operation (SSPND)
001		Alternate function 0 (LED UART RX)	
000		GPIO operation	
3	GP1 Power-Up Settings		
	Bit 7-5:	Don't care	—
	Bit 4: GPIO Output value	—	When GP1 is set as an output GPIO, this value will be present at the GP1 pin at Power-up/Reset.
	Bit 3: GPIO Direction (Input/Output) – Works only when GP1 is set for GPIO operation.	1	GPIO Input mode
		0	GPIO Output mode
	Bit 2-0: GP1 Designation	111-101	Don't care
		100	Alternate function 2 (Interrupt Detection)
		011	Alternate function1 (LED UART TX)
		010	Alternate function 0 (ADC1)
		001	Dedicated function operation (Clock Output)
000		GPIO operation	
4	GP2 Power-Up Settings		
	Bit 7-5:	Don't care	—
	Bit 4: GPIO Output value	—	When GP2 is set as an output GPIO, this value will be present at the GP2 pin at Power-up/Reset.
	Bit 3: GPIO Direction (Input/Output) – Works only when GP2 is set for GPIO operation.	1	GPIO Input mode
		0	GPIO Output mode
	Bit 2-0: GP2 Designation	111-100	Don't care
		011	Alternate function1 (DAC1)
		010	Alternate function 0 (ADC2)
001		Dedicated function operation (Clock Output)	
000		GPIO operation	

TABLE 3-13: SUB-COMMAND STRUCTURE – WRITE GP SETTINGS SUB-COMMAND (CONTINUED)

Byte Index	Function Description	Value	Effect
5	GP3 Power-Up Settings		
	Bit 7-5:	Don't care	—
	Bit 4: GPIO Output value	—	When GP3 is set as an output GPIO, this value will be present at the GP2 pin at Power-up/Reset.
	Bit 3: GPIO Direction (Input/Output) – Works only when GP3 is set for GPIO operation.	1	GPIO Input mode
		0	GPIO Output mode
	Bit 2-0: GP3 Designation	111-100	Don't care
		011	Alternate function 1 (DAC2)
010		Alternate function 0 (ADC3)	
001		Dedicated function operation (LED I2C)	
	000	GPIO operation	
6-63		Don't care	—

TABLE 3-14: SUB-COMMAND STRUCTURE – WRITE USB MANUFACTURER DESCRIPTOR STRING SUB-COMMAND

Byte Index	Value	Effect
0	0xB1	Write Flash Data – command code
1	0x02	Write USB Manufacturer Descriptor String – writes the USB Manufacturer String Descriptor used during the USB enumeration
2	(2)	Number of bytes + 2 in the provided USB Serial Number Descriptor String
3	0x03	The value at this index must always be 0x03.
4 + 2 x Unicode_char_number + 0(1)	—	Lower byte of the 16-bit Unicode character.
4 + 2 x Unicode_char_number + 1(1)	—	Higher byte of the 16-bit Unicode character.

Note 1: “Unicode_char_number” value starts from 0 to a maximum of 30 (included).

2: The value at Byte Index 2 must be 2 + 2 x (number of Unicode characters in the string).

TABLE 3-15: SUB-COMMAND STRUCTURE – WRITE USB PRODUCT DESCRIPTOR STRING SUB-COMMAND

Byte Index	Value	Effect
0	0xB1	Write Flash Data – command code
1	0x03	Write USB Product Descriptor String – writes the USB Product String Descriptor used during the USB enumeration
2	(2)	Number of bytes + 2 in the provided USB Serial Number Descriptor String. The actual string starts at Byte Index 4.
3	0x03	The value at this index must always be 0x03.
4 + 2 x Unicode_char_number + 0(1)	—	Lower byte of the 16-bit Unicode character
4 + 2 x Unicode_char_number + 1(1)	—	Higher byte of the 16-bit Unicode character

Note 1: “Unicode_char_number” value starts from 0 to a maximum of 30 (included).

2: The value at Byte Index 2 must be 2 + 2 x (number of Unicode characters in the string).

MCP2221A

TABLE 3-16: SUB-COMMAND STRUCTURE – WRITE USB SERIAL NUMBER DESCRIPTOR STRING SUB-COMMAND

Byte Index	Value	Effect
0	0xB1	Write Flash Data – command code
1	0x04	Write USB Serial Number Descriptor String – writes the USB Serial Number String Descriptor used during the USB enumeration
2	(2)	Number of bytes + 2 in the provided USB Serial Number Descriptor String. The actual string starts at Byte Index 4.
3	0x03	The value at this index must always be 0x03.
4 + 2 x Unicode_char_number + 0 ⁽¹⁾	—	Lower byte of the 16-bit Unicode character
4 + 2 x Unicode_char_number + 1 ⁽¹⁾	—	Higher byte of the 16-bit Unicode character

Note 1: “Unicode_char_number” value starts from 0 to a maximum of 30 (included).

2: The value at Byte Index 2 must be 2 + 2 x (number of Unicode characters in the string).

3.1.3.1 Responses

TABLE 3-17: RESPONSE STRUCTURE – READ CHIP FACTORY SERIAL NUMBER SUB-COMMAND

Byte Index	Value	Effect
0	0xB1	Write Flash Data – command code
1	0x00	Command completed successfully
	0x02	Command not supported
	0x03	Command not allowed
2-63	Don't care	—

3.1.4 SEND FLASH ACCESS PASSWORD

This command is used to send a user-supplied password that will be compared to the one stored in the device's Flash when Flash updates (Chip/GP configuration, USB strings) are required and the Flash data is password-protected.

In the case where no protection mechanism is in place or the Flash data has been permanently locked, this command has no meaning.

TABLE 3-18: COMMAND STRUCTURE

Byte Index	Value	Effect
0	0xB2	Send Flash Access Password – command code
1	Don't care	—
2	—	Password byte 1
3	—	Password byte 2
4	—	Password byte 3
5	—	Password byte 4
6	—	Password byte 5
7	—	Password byte 6
8	—	Password byte 7
9	—	Password byte 8
10-63	—	Don't care

3.1.4.1 Responses

TABLE 3-19: RESPONSE 1 STRUCTURE

Byte Index	Value	Effect
0	0xB2	Send Flash Access Password – command code echo
1	0x00	Command completed successfully
	0x03	Command not allowed (when the number of failed Flash updates has been reached, no password will be accepted)
2-63	Don't care	—

MCP2221A

3.1.5 I²C WRITE DATA

This command is used to write user-given data to the I²C slave device (the speed is specified by the STATUS/SET Parameters command).

The command will have the following effects:

- The I²C engine will send the “START” condition.
- The selected I²C slave address is sent next and the I²C engine will wait for the slave to send an Acknowledge bit.
- The user data follows next and the I²C engine awaits for the Acknowledge bit from the slave.
- If the requested length is more than 60 bytes, subsequent user bytes will be sent on the bus.
- When the user data length (being sent on the bus) reaches the requested length, the I²C engine will send the “STOP” condition on the bus.

TABLE 3-20: COMMAND STRUCTURE⁽¹⁾

Byte Index	Value	Effect
0	0x90	I ² C Write Data – command code
1	Low Byte	Requested I ² C transfer length – 16-bit value – low byte
2	High Byte	Requested I ² C transfer length – 16-bit value – high byte
3	I ² C Slave Address	8-bit value representing the I ² C slave address to communicate with (even – address to write, odd – address to read) (Note 2)
4-63	—	User data to be sent to the selected I ² C slave device

Note 1: When the requested transfer length is more than 60 bytes, subsequent “I²C Write Data” commands will transport the remainder of the user data (till the requested length).

2: The I²C slave address is represented on 8 bits, with even values for writes and odd for reads. To get the 8-bit address value out of a 7-bit address, the 7-bit value needs to be shifted left by 1 position. For write operations use the shifted value, while for reads add 1 to the shifted value.

3.1.5.1 Responses

TABLE 3-21: RESPONSE 1 STRUCTURE

Byte Index	Value	Effect
0	0x90	I ² C Write Data – command code echo
1	0x00	Command completed successfully
	0x01	I ² C Engine is busy (command not completed)
2	—	Reserved
3-63	Don't care	—

3.1.6 I²C WRITE DATA REPEATED-START

This command is used to write user-given data to the I²C slave device (the speed is specified by the STATUS/SET Parameters command).

The command will have the following effects:

- The I²C engine will send the “Repeated-START” condition.
- The selected I²C slave address is sent next and the I²C engine will wait for the slave to send an Acknowledge bit.

- The user data follows next and the I²C engine waits for the Acknowledge bit from the slave.
- If the requested length is more than 60 bytes, subsequent user bytes will be sent on the bus.
- When the user data length (being sent on the bus) reaches the requested length, the I²C engine will send the “STOP” condition on the bus.

TABLE 3-22: COMMAND STRUCTURE (1)

Byte Index	Value	Effect
0	0x92	I ² C Write Data Repeated-START – command code (cl2C_CMD_RSTART_WRDATA7)
1	Low Byte	Requested I ² C transfer length – 16-bit value – low byte
2	High Byte	Requested I ² C transfer length – 16-bit value – high byte
3	I ² C Slave Address	8-bit value representing the I ² C slave address to communicate with (even – address to write, odd – address to read) (Note 2)
4-63	—	User data to be sent to the selected I ² C slave device

Note 1: When the requested transfer length is more than 60 bytes, subsequent “I²C Write Data Repeated-START” commands will transport the remainder of the user data (till the requested length).

- 2:** The I²C slave address is represented on 8 bits, with even values for writes and odd for reads. To get the 8-bit address value out of a 7-bit address, the 7-bit value needs to be shifted left by 1 position. For write operations use the shifted value, while for reads add 1 to the shifted value.

3.1.6.1 Responses

TABLE 3-23: RESPONSE 1 STRUCTURE

Byte Index	Value	Effect
0	0x92	I ² C Write Data Repeated-START – command code echo (cl2C_CMD_RSTART_WRDATA7)
1	0x00	Command completed successfully
	0x01	I ² C Engine is busy (command not completed)
2	—	Reserved
3-63	Don't care	—

MCP2221A

3.1.7 I²C WRITE DATA NO STOP

This command is used to write user-given data to the I²C slave device (the speed is specified by the STATUS/SET Parameters command).

The command will have the following effects:

- The I²C engine will send the “START” condition.
- The selected I²C slave address is sent next and the I²C engine will wait for the slave to send an Acknowledge bit.

- The user data follows next and the I²C engine waits for the Acknowledge bit from the slave.
- If the requested length is more than 60 bytes, subsequent user bytes will be sent on the bus.
- When the user data length (being sent on the bus) reaches the requested length, the I²C engine will **not** send the “STOP” condition on the bus.

TABLE 3-24: COMMAND STRUCTURE (1)

Byte Index	Value	Effect
0	0x94	I ² C Write Data No STOP – command code
1	Low Byte	Requested I ² C transfer length – 16-bit value – low byte
2	High Byte	Requested I ² C transfer length – 16-bit value – high byte
3	I ² C Slave Address	8-bit value representing the I ² C slave address to communicate with (even – address to write, odd – address to read) (Note 2)
4-63	—	User data to be sent to the selected I ² C slave device

- Note 1:** When the requested transfer length is more than 60 bytes, subsequent “I²C Write Data No STOP” commands will transport the remainder of the user data (till the requested length).
- 2:** The I²C slave address is represented on 8 bits, with even values for writes and odd for reads. To get the 8-bit address value out of a 7-bit address, the 7-bit value needs to be shifted left by 1 position. For write operations use the shifted value, while for reads add 1 to the shifted value.

3.1.7.1 Responses

TABLE 3-25: RESPONSE 1 STRUCTURE

Byte Index	Value	Effect
0	0x94	I ² C Write Data No STOP – command code echo
1	0x00	Command completed successfully
	0x01	I ² C Engine is busy (command not completed)
2	—	Reserved
3-63	Don't care	—

3.1.8 I²C READ DATA

This command is used to read user-given data to the I²C slave device (the speed is specified by the STATUS/SET Parameters command).

The command will have the following effects:

- The I²C engine will send the “START” condition.
- The selected I²C slave address is sent next and the I²C engine will wait for the slave to send an Acknowledge bit.
- The user data is read next and the I²C engine sends the Acknowledge bit to the slave.
- If the requested length is more than 60 bytes, subsequent user bytes will be read from the I²C slave on the bus.
- When the user data length (being sent on the bus) reaches the requested length, the I²C engine will send the “STOP” condition on the bus.

TABLE 3-26: COMMAND STRUCTURE

Byte Index	Value	Effect
0	0x91	I ² C Read Data – command code
1	Low Byte	Requested I ² C transfer length – 16-bit value – low byte
2	High Byte	Requested I ² C transfer length – 16-bit value – high byte
3	I ² C Slave Address	8-bit value representing the I ² C slave address to communicate with (even – address to write, odd – address to read) (Note 1)
4-63	Don't care	—

Note 1: The I²C slave address is represented on 8 bits, with even values for writes and odd for reads. To get the 8-bit address value out of a 7-bit address, the 7-bit value needs to be shifted left by 1 position. For write operations use the shifted value, while for reads add 1 to the shifted value.

3.1.8.1 Responses

TABLE 3-27: RESPONSE 1 STRUCTURE

Byte Index	Value	Effect
0	0x91	I ² C Read Data – command code echo
1	0x00	Command completed successfully
	0x01	I ² C Engine is busy (command not completed)
2	—	Reserved
3-63	Don't care	—

MCP2221A

3.1.9 I²C READ DATA REPEATED-START

This command is used to read user-given data to the I²C slave device (the speed is specified by the STATUS/SET Parameters command).

The command will have the following effect:

- The I²C engine will send the “Repeated-START” condition.
- The selected I²C slave address is sent next and the I²C engine will wait for the slave to send an Acknowledge bit.

- The user data is read next and the I²C engine sends the Acknowledge bit to the slave.
- If the requested length is more than 60 bytes, subsequent user bytes will be read from the I²C slave on the bus.
- When the user data length (being sent on the bus) reaches the requested length, the I²C engine will send the “STOP” condition on the bus.

TABLE 3-28: COMMAND STRUCTURE

Byte Index	Value	Effect
0	0x93	I ² C Read Data Repeated-START – command code
1	Low Byte	Requested I ² C transfer length – 16-bit value – low byte
2	High Byte	Requested I ² C transfer length – 16-bit value – high byte
3	I ² C Slave Address	8-bit value representing the I ² C slave address to communicate with (even – address to write, odd – address to read) (Note 1)
4-63	Don't care	—

Note 1: The I²C slave address is represented on 8 bits, with even values for writes and odd for reads. To get the 8-bit address value out of a 7-bit address, the 7-bit value needs to be shifted left by 1 position. For write operations use the shifted value, while for reads add 1 to the shifted value.

3.1.9.1 Responses

TABLE 3-29: RESPONSE 1 STRUCTURE

Byte Index	Value	Effect
0	0x93	I ² C Read Data Repeated-START – command code echo
1	0x00	Command completed successfully
	0x01	I ² C Engine is busy (command not completed)
2	—	Reserved
3-63	Don't care	—

3.1.10 I²C READ DATA – GET I²C DATA

This command is used to read back the data from the I²C slave device.

TABLE 3-30: COMMAND STRUCTURE

Byte Index	Value	Effect
0	0x40	I ² C Read Data – Get I ² C Data – command code
1-63	Don't care	—

3.1.10.1 Responses

TABLE 3-31: RESPONSE 1 STRUCTURE

Byte Index	Value	Effect
0	0x40	I ² C Read Data – Get I ² C Data – command code echo
1	0x00	Command completed successfully
	0x41	Error reading the I ² C slave data from the I ² C engine
2	—	Reserved
3	0-60	The number of read-back data bytes to follow in this packet: from 0 to a maximum of 60 bytes of read-back bytes.
	127	This value is signaled when an error has occurred and the following data should not be taken into account.
4-63	—	User Data or Don't care

MCP2221A

3.1.11 SET GPIO OUTPUT VALUES

This command is used to change the GPIO output value for those GP pins assigned for GPIO operation (GPIO outputs).

TABLE 3-32: COMMAND STRUCTURE

Byte Index	Function Description	Value	Effect
0	—	0x50	Set GPIO Output Values – command code
1	—	Don't care	—
2	Alter GP0 output (enable/disable)	0x00	Do not modify GP0 output (if GP0 is set as GPIO output)
		Any other value	The next byte (index 3) will be the value used to set GP0 output (only if GP0 is set for GPIO output).
3	GP0 output value	0x00	GP0 (if set up for GPIO output operation) will take a logical value of '0'
		Any other value	GP0 (if set up for GPIO output operation) will take a logical value of '1'
4	Alter GP0 pin direction (enable/disable)	0x00	Leave the GP0 GPIO designation as is (input or output)
		Any other value	The next byte (index 5) will be the value used to set GP0's pin direction (only if GP0 is set for GPIO operation)
5	GP0 pin direction (input or output)	0x00	Set GP0 GPIO as output
		Any other value	GP0 (if set up for GPIO operation) will be set as a digital input
6	Alter GP1 output (enable/disable)	0x00	Do not modify GP1 output (if GP1 is set as GPIO output)
		Any other value	The next byte (index 7) will be the value used to set GP1 output (only if GP1 is set for GPIO output).
7	GP1 output value	0x00	GP1 (if set up for GPIO output operation) will take a logical value of '0'
		Any other value	GP1 (if set up for GPIO output operation) will take a logical value of '1'
8	Alter GP1 pin direction (enable/disable)	0x00	Leave the GP1 GPIO designation as is (input or output)
		Any other value	The next byte (index 9) will be the value used to set GP1's pin direction (only if GP1 is set for GPIO operation)
9	GP1 pin direction (input or output)	0x00	Set GP1 GPIO as output
		Any other value	GP1 (if set up for GPIO operation) will be set as a digital input
10	Alter GP2 output (enable/disable)	0x00	Do not modify GP2 output (if GP2 is set as GPIO output)
		Any other value	The next byte (index 11) will be the value used to set GP2 output (only if GP2 is set for GPIO output).
11	GP2 output value	0x00	GP2 (if GP2 is set up for GPIO output operation) will take a logical value of '0'
		Any other value	GP2 (if GP2 is set up for GPIO output operation) will take a logical value of '1'
12	Alter GP2 pin direction (enable/disable)	0x00	Leave the GP2 GPIO designation as is (input or output)
		Any other value	The next byte (index 13) will be the value used to set GP2's pin direction (only if GP2 is set for GPIO operation)
13	GP2 pin direction (input or output)	0x00	Set GP2 GPIO as output
		Any other value	GP2 (if set up for GPIO operation) will be set as a digital input

TABLE 3-32: COMMAND STRUCTURE (CONTINUED)

Byte Index	Function Description	Value	Effect
14	Alter GP3 output (enable/disable)	0x00	Do not modify GP3 output (if GP3 is set as GPIO output)
		Any other value	The next byte (index 11) will be the value used to set GP3 output (only if GP3 is set for GPIO output)
15	GP3 output value	0x00	GP3 (if set up for GPIO output operation) will take a logical value of '0'.
		Any other value	GP3 (if set up for GPIO output operation) will take a logical value of '1'
16	Alter GP3 pin direction (enable/disable)	0x00	Leave the GP3 GPIO designation as is (input or output)
		Any other value	The next byte (index 17) will be the value used to set GP3's pin direction (only if GP3 is set for GPIO operation)
17	GP3 pin direction (input or output)	0x00	Set GP3 GPIO as output
		Any other value	GP3 (if set up for GPIO operation) will be set as a digital input
18-63	Reserved	0x00	—

3.1.11.1 Responses

TABLE 3-33: RESPONSE 1 STRUCTURE

Byte Index	Function Description	Value	Effect
0	—	0x50	Set GPIO Output Values – command code
1	—	0x00	Command completed successfully
2	Alter GP0 output (enable/disable) status	0xEE	If GP0 is not set for GPIO operation
		Any other value	If GP0 is already set for GPIO operation, the value will be copied from the same byte index in the command structure
3	GP0 output value status	0xEE	If GP0 is not set for GPIO operation
		Any other value	If GP0 is already set for GPIO operation, the value will be copied from the same byte index in the command structure
4	Alter GP0 pin direction (enable/disable)	0xEE	If GP0 is not set for GPIO operation
		Any other value	If GP0 is already set for GPIO operation, the value will be copied from the same byte index in the command structure
5	GP1 pin direction (input or output)	0xEE	If GP1 is not set for GPIO operation
		Any other value	If GP1 is already set for GPIO operation, the value will be copied from the same byte index in the command structure
6	Alter GP1 output (enable/disable) status	0xEE	If GP1 is not set for GPIO operation
		Any other value	If GP1 is already set for GPIO operation, the value will be copied from the same byte index in the command structure
7	GP1 output value status	0xEE	If GP1 is not set for GPIO operation
		Any other value	If GP1 is already set for GPIO operation, the value will be copied from the same byte index in the command structure

MCP2221A

TABLE 3-33: RESPONSE 1 STRUCTURE (CONTINUED)

Byte Index	Function Description	Value	Effect
8	Alter GP1 pin direction (enable/disable)	0xEE	If GP1 is not set for GPIO operation
		Any other value	If the GP1 is already set for GPIO operation, the value will be copied from the same byte index in the command structure
9	GP1 pin direction (input or output)	0xEE	If GP1 is not set for GPIO operation
		Any other value	If GP1 is already set for GPIO operation, the value will be copied from the same byte index in the command structure
10	Alter GP2 output (enable/disable) status	0xEE	If GP2 is not set for GPIO operation
		Any other value	If GP2 is already set for GPIO operation, the value will be copied from the same byte index in the command structure
11	GP2 output value status	0xEE	If GP2 is not set for GPIO operation
		Any other value	If GP2 is already set for GPIO operation, the value will be copied from the same byte index in the command structure
12	Alter GP2 pin direction (enable/disable)	0xEE	If GP2 is not set for GPIO operation
		Any other value	If GP2 is already set for GPIO operation, the value will be copied from the same byte index in the command structure
13	GP2 pin direction (input or output)	0xEE	If GP2 is not set for GPIO operation
		Any other value	If GP2 is already set for GPIO operation, the value will be copied from the same byte index in the command structure
14	Alter GP3 output (enable/disable) status	0xEE	If GP3 is not set for GPIO operation
		Any other value	If GP3 is already set for GPIO operation, the value will be copied from the same byte index in the command structure
15	GP3 output value status	0xEE	If GP3 is not set for GPIO operation
		Any other value	If GP3 is already set for GPIO operation, the value will be copied from the same byte index in the command structure
16	Alter GP3 pin direction (enable/disable)	0xEE	If GP3 is not set for GPIO operation
		Any other value	If GP3 is already set for GPIO operation, the value will be copied from the same byte index in the command structure
17	GP3 pin direction (input or output)	0xEE	If GP3 is not set for GPIO operation
		Any other value	If GP3 is already set for GPIO operation, the value will be copied from the same byte index in the command structure
18-63	—	Don't care	—

3.1.12 GET GPIO VALUES

This command is used to retrieve the GPIO direction and pin value for those GP pins assigned for GPIO operation (GPIO inputs or outputs).

TABLE 3-34: COMMAND STRUCTURE

Byte Index	Value	Effect
0	0x51	Get GPIO Values – command code
1-63	Don't care	—

3.1.12.1 Responses

TABLE 3-35: RESPONSE 1 STRUCTURE

Byte Index	Function Description	Value	Effect
0	—	0x51	Get GPIO Values – command code
1	—	0x00	Command completed successfully
2	GP0 pin value	0xEE	If GP0 is not set for GPIO operation
		Other values (0x00 or 0x01)	If GP0 is already set for GPIO operation, the value represents the GP0 logic pin value
3	GP0 direction value	0xEF	If GP0 is not set for GPIO operation
		Other values (0x00 or 0x01)	If GP0 is already set for GPIO operation, the value represents the GP0 pin designation (0x00 for output and 0x01 for input)
4	GP1 pin value	0xEE	If GP1 is not set for GPIO operation
		Other values (0x00 or 0x01)	If GP1 is already set for GPIO operation, the value represents the GP1 logic pin value
5	GP1 direction value	0xEF	If GP1 is not set for GPIO operation
		Other values (0x00 or 0x01)	If GP1 is already set for GPIO operation, the value represents the GP1 pin designation (0x00 for output and 0x01 for input)
6	GP2 pin value	0xEE	If GP2 is not set for GPIO operation
		Other values (0x00 or 0x01)	If GP2 is already set for GPIO operation, the value represents the GP2 logic pin value
7	GP2 direction value	0xEF	If GP2 is not set for GPIO operation
		Other values (0x00 or 0x01)	If GP2 is already set for GPIO operation, the value represents the GP2 pin designation (0x00 for output and 0x01 for input)
8	GP3 pin value	0xEE	If GP3 is not set for GPIO operation
		Other values (0x00 or 0x01)	If GP3 is already set for GPIO operation, the value represents the GP3 logic pin value
9	GP3 direction value	0xEF	If GP3 is not set for GPIO operation
		Other values (0x00 or 0x01)	If GP3 is already set for GPIO operation, the value represents the GP3 pin designation (0x00 for output and 0x01 for input)
10-63	—	Don't care	—

MCP2221A

3.1.13 SET SRAM SETTINGS

This command is used to alter various run time Chip settings. The altered settings reside in SRAM memory and they will not affect the chip's Power-up/Reset default settings. These altered settings will be active until the next chip Power-up/Reset.

TABLE 3-36: COMMAND STRUCTURE

Byte Index	Function Description	Value	Effect
0	—	0x60	Set SRAM settings – command code
1	—	Don't care	—
2	Clock Output Divider Value – this allows the user to modify the clock output value on the fly, at run-time		
	Bit 7: Enable loading of a new clock divider	1	The 4-0 bits will be loaded into the clock divider
		0	Clock divider value won't be altered
	Bit 6-5	Don't care	—
	Bit 4-3: Duty cycle	00	0% duty cycle
		01	25% duty cycle
		10	50% duty cycle
		11	75% duty cycle
	Bit 2-0: Clock divider value	—	—
3	DAC Voltage Reference – this allows the user to modify the DAC reference voltage		
	Bit 7: Enable loading of a new DAC reference	1	Bits 2-0 will be used for DAC reference voltage selection
		0	DAC reference will remain unaltered
	Bit 6-3	Don't care	—
	Bit 2-1: DAC VRM voltage selection. These bits are used to change the DAC VRM voltage	11	VRM voltage is 4.096V (only if VDD is higher than this value)
		10	VRM voltage is 2.048V
		01	VRM voltage is 1.024V
		00	VRM voltage is off
	Bit 0: This bit is used to change the DAC reference voltage	1	DAC voltage reference is the internal DAC voltage reference module (DAC VRM)
		0	DAC voltage reference is VDD
4	Set DAC Output Value		
	Bit 7: Enable loading of a new DAC value	1	Bits 4-0 will be used for DAC reference voltage selection
		0	The current DAC value will remain unaltered
	Bit 6-5	Don't care	—
	Bit 4-0: The new DAC value	—	—

TABLE 3-36: COMMAND STRUCTURE (CONTINUED)

Byte Index	Function Description	Value	Effect
5	ADC Voltage Reference – this allows the user to modify the ADC reference voltage		
	Bit 7: Enable loading of a new ADC reference	1	Bits 2-0 will be used for ADC reference voltage selection
		0	ADC reference will remain unaltered
	Bit 6-3	Don't care	—
	Bit 2-1: These bits are used to change the DAC VRM voltage	11	VRM voltage is 4.096V (only if VDD is higher than this value)
		10	VRM voltage is 2.048V
		01	VRM voltage is 1.024V
		00	VRM voltage is off
Bit 0: This bit is used to change the DAC reference voltage	1	VDD ADC voltage reference is the internal ADC voltage reference module (ADC VRM)	
	0	ADC voltage reference is V _{DD}	
6	Setup the interrupt detection mechanism and clear the detection flag – useful for preparing the interrupt detection module to detect a new interrupt condition		
	Bit 7: Enable the modification of the interrupt detection conditions	1	The interrupt detection settings and flag will change
		0	The interrupt detection settings and flag will remain unchanged
	Bit 6-5	Don't care	—
	Bit 4	—	Enable the modification of the positive edge detection
	Bit 3: The new value for the positive edge detector	1	Interrupt detection will trigger on positive edges
		0	Interrupt detection will not trigger on positive edges
	Bit 2	—	Enable the modification of the negative edge detection
	Bit 1: The new value for the negative edge detector	1	Interrupt detection will trigger on negative edges
		0	Interrupt detection will not trigger on negative edges
Bit 0: Clear the interrupt detection flag	1	Clear the interrupt detection flag	
	0	Leave the interrupt detection flag as is	
7	Bit 7: Alter GPIO configuration: alters the current GP designation	1	Alter the GP designation. The values from Byte Index 8 will be used to load a new set of values into the SRAM GP settings.
		0	Do not alter the current GP designation
8	GP0 Settings		
	Bit 7-5	Don't care	—
	Bit 4: GPIO Output value	—	When GP0 is set as an output GPIO, this value will be present at the GP0 pin
	Bit 3: GPIO Direction (Input/Output) – Works only when GP0 is set for GPIO operation	1	GPIO Input mode
		0	GPIO Output mode
	Bit 2-0: GP0 Designation	111-011	Don't care
		010	Alternate function 0 (LED UART RX)
001		Dedicated function operation (SSPND)	
	000	GPIO operation	

MCP2221A

TABLE 3-36: COMMAND STRUCTURE (CONTINUED)

Byte Index	Function Description	Value	Effect
9	GP1 Settings		
	Bit 7-5	Don't care	—
	Bit 4: GPIO Output value	—	When GP1 is set as an output GPIO, this value will be present at the GP1 pin
	Bit 3: GPIO Direction (Input/Output) – Works only when GP1 is set for GPIO operation	1	GPIO Input mode
		0	GPIO Output mode
	Bit 2-0: GP0 Designation	111-101	Don't care
		100	Alternate function 2 (Interrupt Detection)
		011	Alternate function 1 (LED UART TX)
		010	Alternate function 0 (ADC1)
		001	Dedicated function operation (Clock Output)
000	GPIO operation		
10	GP2 Settings		
	Bit 7-5	Don't care	—
	Bit 4: GPIO Output value	—	When GP2 is set as an output GPIO, this value will be present at the GP2 pin
	Bit 3: GPIO Direction (Input/Output) – Works only when GP2 is set for GPIO operation	1	GPIO Input mode
		0	GPIO Output mode
	Bit 2-0: GP2 Designation	111-100	Don't care
		011	Alternate function 1 (DAC1)
		010	Alternate function 0 (ADC2)
		001	Dedicated function operation (USBCFG)
		000	GPIO operation
11	GP3 Settings		
	Bit 7-5	Don't care	—
	Bit 4: GPIO Output value	—	When GP3 is set as an output GPIO, this value will be present at the GP3 pin
	Bit 3: GPIO Direction (Input/Output) – Works only when GP3 is set for GPIO operation	1	GPIO Input mode
		0	GPIO Output mode
	Bit 2-0: GP3 Designation	111-100	Don't care
		011	Alternate function 1 (DAC2)
		010	Alternate function 0 (ADC3)
		001	Dedicated function operation (LED I2C)
		000	GPIO operation
12-63	Reserved	0x00	—

3.1.13.1 Responses

TABLE 3-37: RESPONSE 1 STRUCTURE

Byte Index	Value	Effect
0	0x60	Set SRAM settings – command code echo
1	0x00	Command completed successfully
2-63	Don't care	—

3.1.14 GET SRAM SETTINGS

This command is used to retrieve the run time Chip and GP settings.

TABLE 3-38: COMMAND STRUCTURE

Byte Index	Value	Effect
0	0x61	Get SRAM Settings – command code echo
1-63	0x00	Command completed successfully

3.1.14.1 Responses

TABLE 3-39: RESPONSE 1 STRUCTURE

Byte Index	Function Description	Value	Effect
0	—	0x61	Get SRAM Settings – command code echo
1	—	0x00	Command completed successfully
2	Length in bytes of the SRAM Chip settings area	—	—
3	Length in bytes of the SRAM GP settings area	—	—
4	Bit 7: CDC Serial Number Enumeration Enable	1	The USB serial number will be used during the USB enumeration of the CDC interface
		0	No serial number descriptor will be presented during the USB enumeration
	Bit 6: Initial value for LEDUARTRX pin option	—	This value represents the logic level signaled when no UART RX activity takes places. When the UART RX (of the MCP2221A) is receiving data, the LEDUARTRX pin will take the negated value of this bit.
	Bit 5: Initial value for LEDUARTTX pin option.	—	This value represents the logic level signaled when no UART TX transmission takes place. When the UART TX (of the MCP2221A) is sending data, the LEDUARTTX pin will take the negated value of this bit.
	Bit 4: Initial value for LEDI2C pin option	—	This value represents the logic level signaled when no I ² C traffic occurs. When I ² C traffic is active, the LEDI2C pin (if enabled) will take the negated value of this bit.
	Bit 3: Initial value for SSPND pin option	—	This value represents the logic level signaled when the device is not in Suspend mode. Upon entering Suspend mode, the SSPND pin (if enabled) will take the negated value of this bit.
	Bit 2: Initial value for USBCFG pin option	—	This value represents the logic level signaled when the device is not USB configured. When the device will be USB-configured, the USBCFG pin (if enabled) will take the negated value of this bit.
	Bit 1-0: Chip Configuration security option	10	Permanently locked
		01	Password-protected
00		Unsecured	
5	Bit 7-5	Don't care	—
	Bit 4-0: Clock Output divider value	—	If the GP pin (exposing the clock output) is enabled for clock output operation, the divider value will be used on the 48 MHz USB internal clock and its divided output will be sent to this pin. (Bits 4-3 for duty cycle and bits 2-0 for the clock divider.)

MCP2221A

TABLE 3-39: RESPONSE 1 STRUCTURE (CONTINUED)

Byte Index	Function Description	Value	Effect
6	Bit 7-6: DAC Reference voltage option	11	Reference voltage is 4.096V
		10	Reference voltage is 2.048V
		01	Reference voltage is 1.024V
		00	Reference voltage is off (this is useful for the case in which the DAC uses other reference than VRM DAC; e.g., VDD)
	Bit 5: DAC reference option	1	DAC reference is VRM DAC voltage
		0	DAC reference is VDD
Bit 4-0: Power-up DAC value		—	—
7	Bit 7	Don't care	—
	Bit 6: Interrupt detection – negative edge	—	If set, the interrupt detection flag will be set when a negative edge occurs
	Bit 5: Interrupt detection – positive edge	—	If set, the interrupt detection flag will be set when a positive edge occurs
	Bit 4-3: ADC Reference Voltage	11	Reference voltage is 4.096V (only if VDD is above this voltage)
		10	Reference voltage is 2.048V
		01	Reference voltage is 1.024V
		00	Reference voltage is off (this is useful for the case in which the ADC uses other reference than VRM DAC; e.g., VDD)
	Bit 2: ADC Reference Option	1	ADC reference is VRM ADC
		0	ADC reference is VDD
	Bit 1	Don't care	—
Bit 2	Don't care	—	
8	Lower byte of the 16-bit USB VID value	—	—
9	Higher byte of the 16-bit USB VID value	—	—
10	Lower byte of the 16-bit USB PID value	—	—
11	Higher byte of the 16-bit USB PID value	—	—
12	USB power attributes	—	This value will be used by the MCP2221A's USB Configuration Descriptor (power attributes value) during the USB enumeration
13	USB requested number of mA(s)	—	The requested mA value during the USB enumeration will represent the value at this index multiplied by 2
14	Current supplied-password byte 1	—	—
15	Current supplied-password byte 2	—	—
16	Current supplied-password byte 3	—	—
17	Current supplied-password byte 4	—	—
18	Current supplied-password byte 5	—	—
19	Current supplied-password byte 6	—	—
20	Current supplied-password byte 7	—	—
21	Current supplied-password byte 8	—	—

TABLE 3-39: RESPONSE 1 STRUCTURE (CONTINUED)

Byte Index	Function Description	Value	Effect
22	GP0 Settings		
	Bit 7-5	Don't care	—
	Bit 4: GPIO Output value	—	When the GP0 is set as an output GPIO, this value will be present at the GP0 pin
	Bit 3: GPIO Direction (Input/Output) – Works only when GP0 is set for GPIO operation	1	GPIO Input mode
		0	GPIO Output mode
	Bit 2-0: GP0 Designation	111-011	Don't care
		010	Alternate function 0 (LED UART RX)
		001	Dedicated function operation (SSPND)
000		GPIO operation	
23	GP1 Settings		
	Bit 7-5	Don't care	—
	Bit 4: GPIO Output value	—	When the GP1 is set as an output GPIO, this value will be present at the GP1 pin
	Bit 3: GPIO Direction (Input/Output) – Works only when GP1 is set for GPIO operation	1	GPIO Input mode
		0	GPIO Output mode
	Bit 2-0: GP1 Designation	111-101	Don't care
		100	Alternate function 2 (Interrupt Detection)
		011	Alternate function 1 (LED UART TX)
		010	Alternate function 0 (ADC1)
		001	Dedicated function operation (Clock Output)
		000	GPIO operation
	24	GP2 Settings	
Bit 7-5		Don't care	—
Bit 4: GPIO Output value		—	When the GP2 is set as an output GPIO, this value will be present at the GP2 pin
Bit 3: GPIO Direction (Input/Output) – Works only when GP2 is set for GPIO operation		1	GPIO Input mode
		0	GPIO Output mode
Bit 2-0: GP2 Designation		111-100	Don't care
		011	Alternate function 1 (DAC1)
		010	Alternate function 0 (ADC2)
		001	Dedicated function operation (USBCFG)
000	GPIO operation		

MCP2221A

TABLE 3-39: RESPONSE 1 STRUCTURE (CONTINUED)

Byte Index	Function Description	Value	Effect
25	GP3 Settings		
	Bit 7-5	Don't care	—
	Bit 4: GPIO Output value	—	When the GP3 is set as an output GPIO, this value will be present at the GP3 pin
	Bit 3: GPIO Direction (Input/Output) – Works only when GP3 is set for GPIO operation	1	GPIO Input mode
		0	GPIO Output mode
	Bit 2-0: GP3 Designation	111-100	Don't care
		011	Alternate function 1 (DAC2)
		010	Alternate function 0 (ADC3)
001		Dedicated function operation (LED I2C)	
	000	GPIO operation	
26-63		Don't care	—

3.1.15 RESET CHIP

This command is used to force a Reset of the MCP2221A device. This command is useful when the Flash memory is updated with new data. The MCP2221A would need to be re-enumerated to see the new data.

Note: This command is the only command that does not expect a response.

TABLE 3-40: COMMAND STRUCTURE

Byte Index	Value	Effect
0	0x70	Reset Chip – command code
1	0xAB	—
2	0xCD	—
3	0xEF	—
4-63	0x00	Reserved

4.0 ELECTRICAL CHARACTERISTICS

Absolute Maximum Ratings †(1)

Ambient temperature under bias	-40°C to +85°C
Storage temperature	-65°C to +150°C
Voltage on VDD with respect to VSS	-0.3V to +6.0V
Voltage on $\overline{\text{RST}}$ with respect to VSS	-0.3V to +9.0V
Voltage on VUSB pin with respect to VSS	-0.3V to +4.0V
Voltage on D+ and D- pins with respect to VSS	-0.3V to (VUSB + 0.3V)
Voltage on all other pins with respect to VSS	-0.3V to (VDD + 0.3V)
Total power dissipation(2)	800 mW
Maximum current out of VSS pin	95 mA
Maximum current into VDD pin	95 mA
Clamp current, I _K (V _{PIN} < 0 or V _{PIN} > VDD).....	± 20 mA
Maximum output current sunk by any I/O pin.....	25 mA
Maximum output current sourced by any I/O pin	25 mA
Maximum current sunk by all ports	90 mA
Maximum current sourced by all ports	90 mA

† **NOTICE:** Stresses above those listed under “Absolute Maximum Ratings” may cause permanent damage to the device. This is a stress rating only and functional operation of the device at those or any other conditions above those indicated in the operation listings of this specification is not implied. Exposure above maximum rating conditions for extended periods may affect device reliability.

Note 1: V_{USB} must always be ≤ V_{DD} + 0.3V.

2: Power dissipation is calculated as follows: $P_{DIS} = V_{DD} \times \{I_{DD} - \sum I_{OH}\} + \sum \{(V_{DD} - V_{OH}) \times I_{OH}\} + \sum (V_{OL} \times I_{OL})$.

MCP2221A

4.1 DC CHARACTERISTICS

DC Characteristics		Operating Conditions (unless otherwise indicated): 3.0V ≤ VDD ≤ 5.5V at -40°C ≤ TA ≤ +85°C (I-Temp)					
Param. No.	Characteristic	Sym.	Min.	Typ.	Max.	Units	Conditions
D001	Supply Voltage	VDD	3.0	—	5.5	V	
	POR Release Voltage	VPOR	—	1.6	—	V	
	POR Rearm Voltage	—	—	0.8	—	V	
D003	VDD Rise Rate to Ensure POR	SVDD	0.05	—	—	V/ms	Design guidance only Not tested
D004	Supply Current	IDD	—	—	—	—	
	VDD = 3.0V	—	—	10	12	mA	FOSC = 12 MHz, (330 nF on VUSB)
	VDD = 5.0V	—	—	13	15	mA	
D005	Standby Current	IDDS	—	46	—	μA	
Input Low-Voltage							
D031	Schmitt Trigger (URX)	VIL	—	—	0.2 VDD	V	3.0V ≤ VDD ≤ 5.5V
	TTL (GP pins)		—	—	0.8		4.5V ≤ VDD ≤ 5.5V
Input High-Voltage							
D041	Schmitt Trigger (URX)	VIH	0.8 VDD	—	VDD	V	3.0V ≤ VDD ≤ 5.5V
	TTL (GP pins)		2.0	—	VDD		4.5V ≤ VDD ≤ 5.5V
Input Leakage Current							
D060	GP, URX	IIL	—	±50	±100	nA	VSS ≤ VPIN ≤ VDD, pin at high-Z
Output Low-Voltage							
D080	GP, UTX	VOL	—	—	0.6	V	IOI = 8.0 mA, VDD = 5.0V
			—	—	0.6		IOI = 6.0 mA, VDD = 3.3V
Output High-Voltage							
D090	GP, UTX	VOH	VDD – 0.7	—	—	V	IOH = -3.5 mA, VDD = 5.0V
			VDD – 0.7	—	—		IOH = -3.0 mA, VDD = 3.3V
Capacitive Loading Specs on Output Pins							
D102	GPIO	CIO	—	—	50	pF	Note 1

Note 1: Characterized only, not 100% tested.

FIGURE 4-1: POR AND POR REARM WITH SLOW RISING V_{DD}

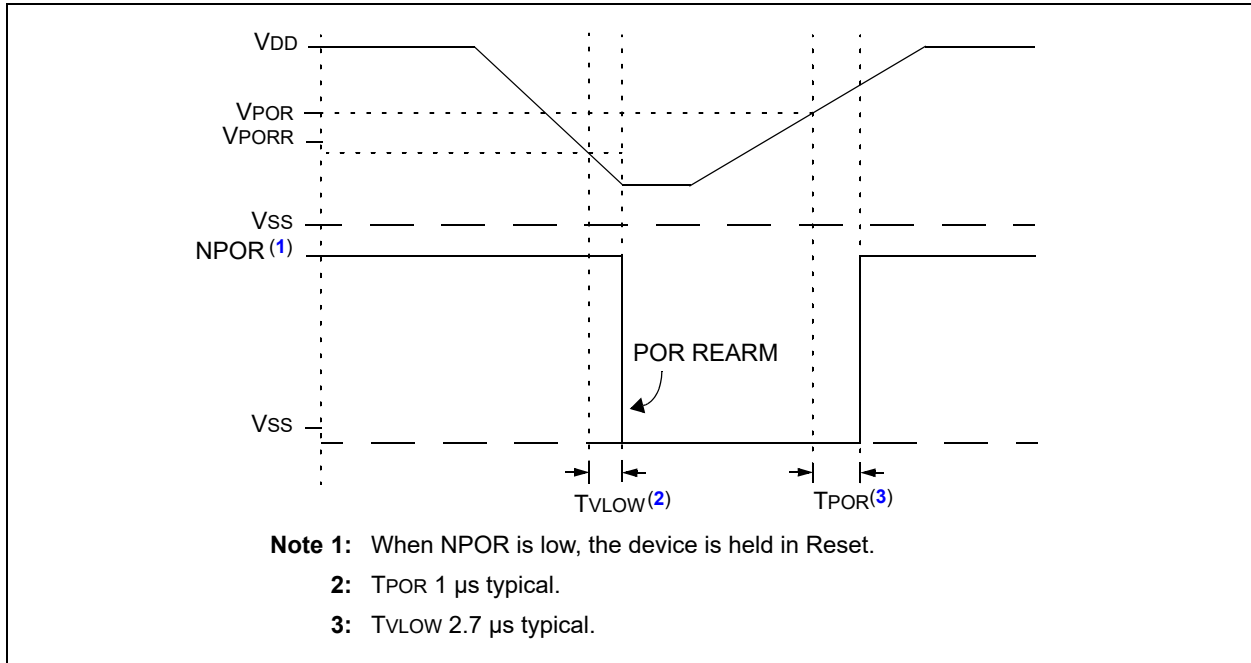

TABLE 4-1: USB MODULE SPECIFICATIONS

DC Characteristics		Operating Conditions (unless otherwise indicated): 3.0V ≤ V _{DD} ≤ 5.5V at -40°C ≤ T _A ≤ +85°C (I-Temp)					
Param. No.	Characteristic	Sym.	Min.	Typ.	Max.	Units	Conditions
D313	USB Voltage	V _{USB}	3.0	—	3.6	V	Voltage on the V _{USB} pin must be in this range for proper USB operation
D314	Input Leakage on Pin	I _{IL}	—	—	±1	μA	V _{SS} ≤ V _{PIN} ≤ V _{DD} pin at high-impedance
D315	Input Low Voltage for USB Buffer	V _{ILUSB}	—	—	0.8	V	For V _{USB} range
D316	Input High Voltage for USB Buffer	V _{IHUSB}	2.0	—	—	V	For V _{USB} range
D318	Differential Input Sensitivity	V _{DIFS}	—	—	0.2	V	The difference between D+ and D- must exceed this value while V _{CM} is met
D319	Differential Common Mode Range	V _{CM}	0.8	—	2.5	V	
D320	Driver Output Impedance ⁽¹⁾	Z _{OUT}	28	—	44	Ω	
D321	Voltage Output Low	V _{OL}	0.0	—	0.3	V	1.5 kΩ load connected to 3.6V
D322	Voltage Output High	V _{OH}	2.8	—	3.6	V	1.5 kΩ load connected to ground

Note 1: The D+ and D- signal lines have been built-in impedance matching resistors. No external resistors, capacitors or magnetic components are necessary on the D+/D- signal paths between the MCP2221A family device and the USB cable.

MCP2221A

TABLE 4-2: A/D CONVERTER (ADC) CHARACTERISTICS

Standard Operating Conditions (unless otherwise stated) Operating temperature Tested at +25°C							
Param No.	Characteristic	Sym.	Min.	Typ.	Max.	Units	Conditions
AD01	Resolution	NR	—	—	10	bit	
AD08	Recommended Impedance of Analog Voltage Source	ZAIN	—	—	10	kΩ	Can go higher if external 0.01μF capacitor is present on input pin.

TABLE 4-3: DIGITAL-TO-ANALOG CONVERTER (DAC) SPECIFICATIONS

Operating Conditions: 3.0V < VDD < 5.5V, -40°C < TA < +85°C (unless otherwise stated).							
Param No.	Characteristic	Sym.	Min.	Typ.	Max.	Units	Conditions
DAC01*	Step Size	CLSB	—	VDD/32	—	V	
DAC02*	Absolute Accuracy	CACC	—	—	± 1/2	LSb	
DAC03*	Unit Resistor Value (R)	CR	—	5K	—	Ω	
DAC04*	Settling Time ⁽¹⁾	CST	—	—	10	μS	

* These parameters are characterized but not tested.

Note 1: Settling time measured while DACVAL<4:0> transitions from '0000' to '1111'.

TABLE 4-4: THERMAL CONSIDERATIONS

Standard Operating Conditions (unless otherwise stated) Operating temperature: -40°C ≤ TA ≤ +85°C (I-Temp)							
Param. No.	Characteristic	Sym.	Typ.	Units	Conditions		
TH01	Thermal Resistance Junction to Ambient	θJA	70	°C/W	14-pin PDIP package		
			95.3	°C/W	14-pin SOIC package		
			100	°C/W	14-pin TSSOP package		
			45.7	°C/W	16-pin QFN 4 x 4 mm package		
TH02	Thermal Resistance Junction to Case	θJC	32	°C/W	14-pin PDIP package		
			31	°C/W	14-pin SOIC package		
			24.4	°C/W	14-pin TSSOP package		
			6.3	°C/W	16-pin QFN 4 x 4 mm package		
TH03	Maximum Junction Temperature	TJMAX	+150	°C			
TH04	Power Dissipation	PD	—	W	PD = PINTERNAL + PI/O		
TH05	Internal Power Dissipation	PINTERNAL	—	W	PINTERNAL = IDD x VDD ⁽¹⁾		
TH06	I/O Power Dissipation	PI/O	—	W	PI/O = Σ(IOL x VOL) + Σ(IOH x (VDD - VOH))		
TH07	Derated Power	PDER	—	W	PDER = PDMAX (TJ - TA)/θJA ^(2, 3)		

Note 1: IDD is the current to run the device alone without driving any load on the output pins.

2: TA = Ambient Temperature.

3: TJ = Junction Temperature.

4.2 AC Characteristics

4.2.1 TIMING PARAMETER SYMBOLOGY

The timing parameter symbols have been created in one of the following formats:

1. TppS2ppS

T	
F	Frequency
E	Error

2. TppS

T	Time
---	------

Lowercase letters (pp) and their meanings:

pp		osc	Oscillator
io	Input or Output pin	tx	Transmit
rx	Receive	RST	Reset
bitclk	RX/TX BITCLK		
drt	Device Reset Timer		

Uppercase letters and their meanings:

S		P	Period
F	Fall	R	Rise
H	High	V	Valid
I	Invalid (high-impedance)	Z	High-impedance
L	Low		

4.2.2 TIMING CONDITIONS

The operating temperature and voltage specified in [Table 4-5](#) apply to all timing specifications, unless otherwise noted. [Figure 4-2](#) specifies the load conditions for the timing specifications.

TABLE 4-5: TEMPERATURE AND VOLTAGE SPECIFICATIONS – AC

AC CHARACTERISTICS	Standard Operating Conditions (unless otherwise stated)
	Operating temperature $-40^{\circ}\text{C} \leq T_A \leq +85^{\circ}\text{C}$
	Operating voltage VDD range as described in DC spec, Section 4.1 “DC Characteristics” .

FIGURE 4-2: LOAD CONDITIONS FOR DEVICE TIMING SPECIFICATIONS

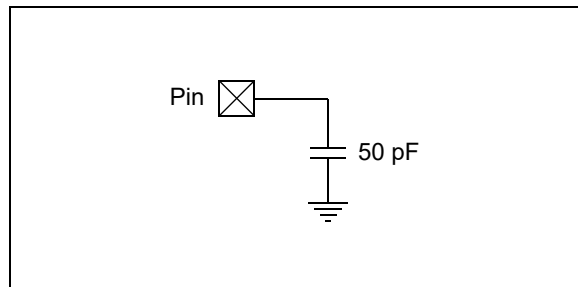

MCP2221A

4.2.3 TIMING DIAGRAMS AND SPECIFICATIONS

TABLE 4-6: RESET, OSCILLATOR START-UP TIMER AND POWER-UP TIMER PARAMETERS

Standard Operating Conditions (unless otherwise stated) Operating Temperature: $-40^{\circ}\text{C} \leq T_A \leq +85^{\circ}\text{C}$							
Param No.	Characteristic	Sym.	Min.	Typ. [†]	Max.	Units	Conditions
30	$\overline{\text{RST}}$ Pulse Width (low)	TRST	2	—	—	μs	
31	Power-up Timer	TPWRT	40	65	140	ms	
32	Oscillator Start-Up Time	TOST	—	1024	—	TOST	

* These parameters are characterized but not tested.

† Data in the "Typ." column is at 5V, +25°C, unless otherwise stated. These parameters are for design guidance only and are not tested.

5.0 PACKAGING INFORMATION

5.1 Package Marking Information

14-Lead PDIP (300 mil)

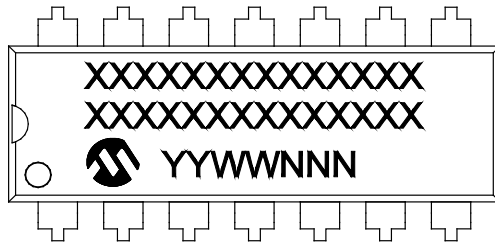

Example

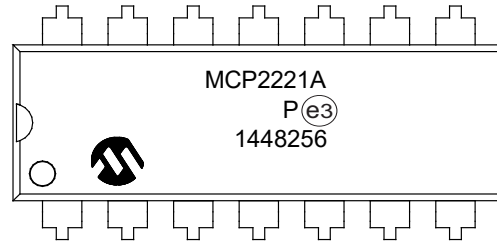

14-Lead SOIC (3.90 mm)

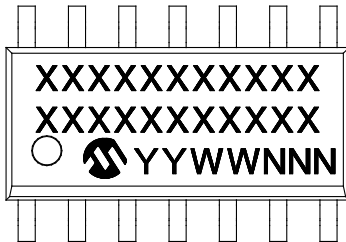

Example

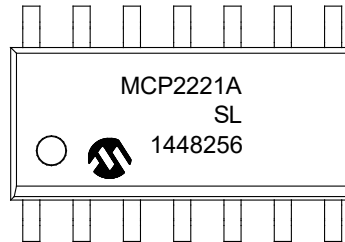

14-Lead TSSOP (4.4 mm)

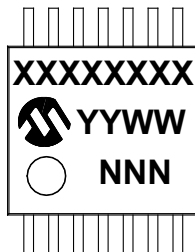

Example

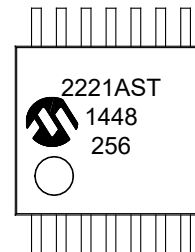

16-Lead QFN (4x4x0.9 mm)

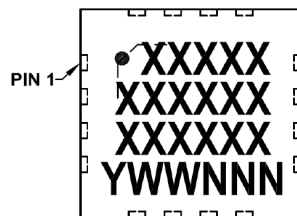

Example

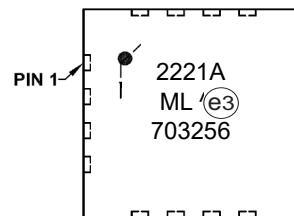

Legend:	XX...X	Customer-specific information
	Y	Year code (last digit of calendar year)
	YY	Year code (last 2 digits of calendar year)
	WW	Week code (week of January 1 is week '01')
	NNN	Alphanumeric traceability code
	(e3)	Pb-free JEDEC designator for Matte Tin (Sn)
	*	This package is Pb-free. The Pb-free JEDEC designator (e3) can be found on the outer packaging for this package.

Note: In the event the full Microchip part number cannot be marked on one line, it will be carried over to the next line, thus limiting the number of available characters for customer-specific information.

MCP2221A

14-Lead Plastic Dual In-Line (P) – 300 mil Body [PDIP]

Note: For the most current package drawings, please see the Microchip Packaging Specification located at <http://www.microchip.com/packaging>

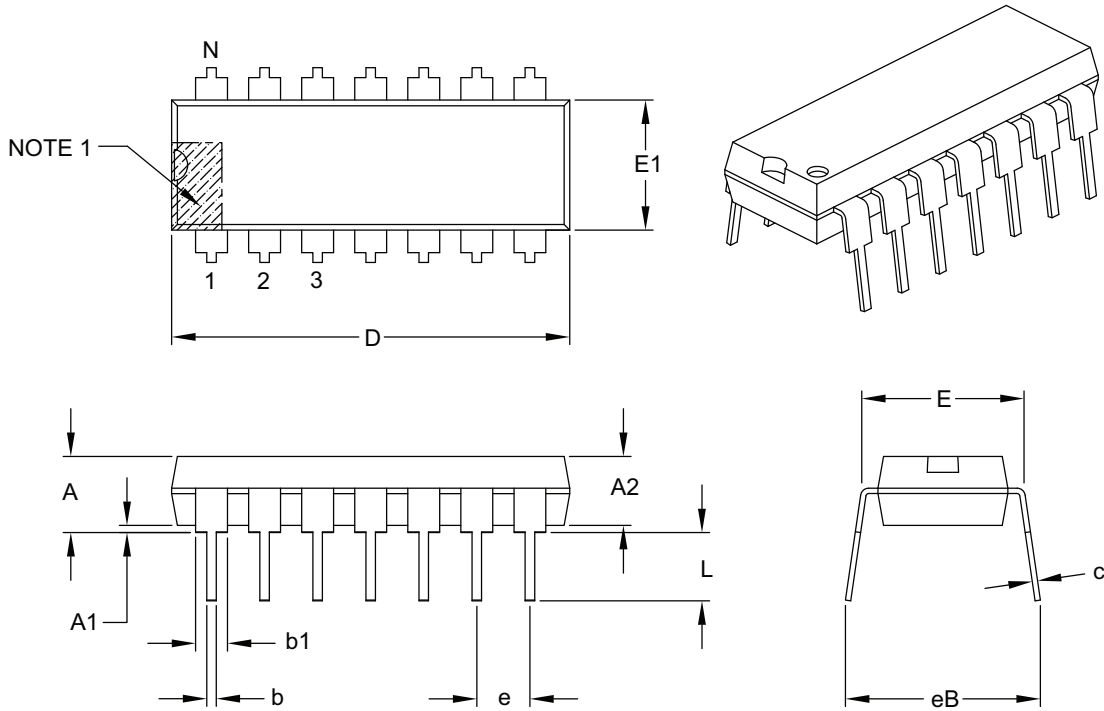

Dimension Limits	Units	INCHES		
		MIN	NOM	MAX
Number of Pins	N	14		
Pitch	e	.100 BSC		
Top to Seating Plane	A	–	–	.210
Molded Package Thickness	A2	.115	.130	.195
Base to Seating Plane	A1	.015	–	–
Shoulder to Shoulder Width	E	.290	.310	.325
Molded Package Width	E1	.240	.250	.280
Overall Length	D	.735	.750	.775
Tip to Seating Plane	L	.115	.130	.150
Lead Thickness	c	.008	.010	.015
Upper Lead Width	b1	.045	.060	.070
Lower Lead Width	b	.014	.018	.022
Overall Row Spacing §	eB	–	–	.430

Notes:

- Pin 1 visual index feature may vary, but must be located with the hatched area.
- § Significant Characteristic.
- Dimensions D and E1 do not include mold flash or protrusions. Mold flash or protrusions shall not exceed .010" per side.
- Dimensioning and tolerancing per ASME Y14.5M.

BSC: Basic Dimension. Theoretically exact value shown without tolerances.

Microchip Technology Drawing C04-005B

14-Lead Plastic Small Outline (SL) - Narrow, 3.90 mm Body [SOIC]

Note: For the most current package drawings, please see the Microchip Packaging Specification located at <http://www.microchip.com/packaging>

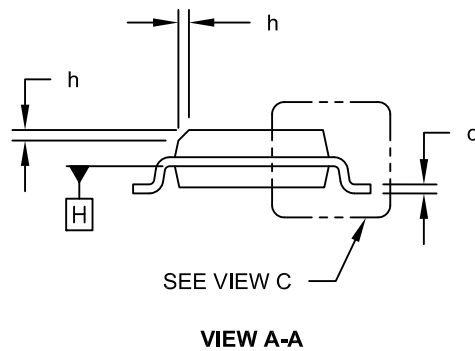
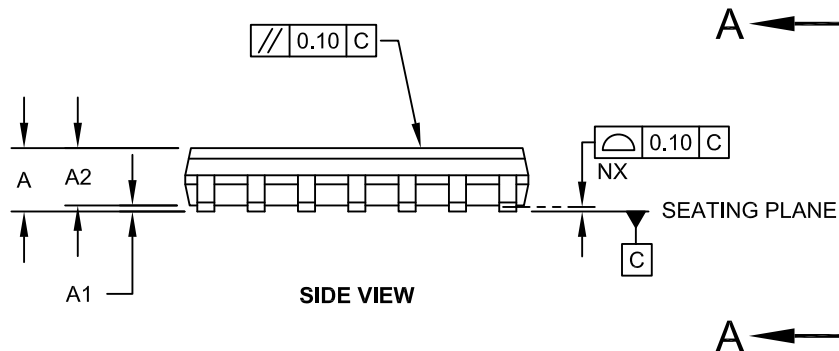
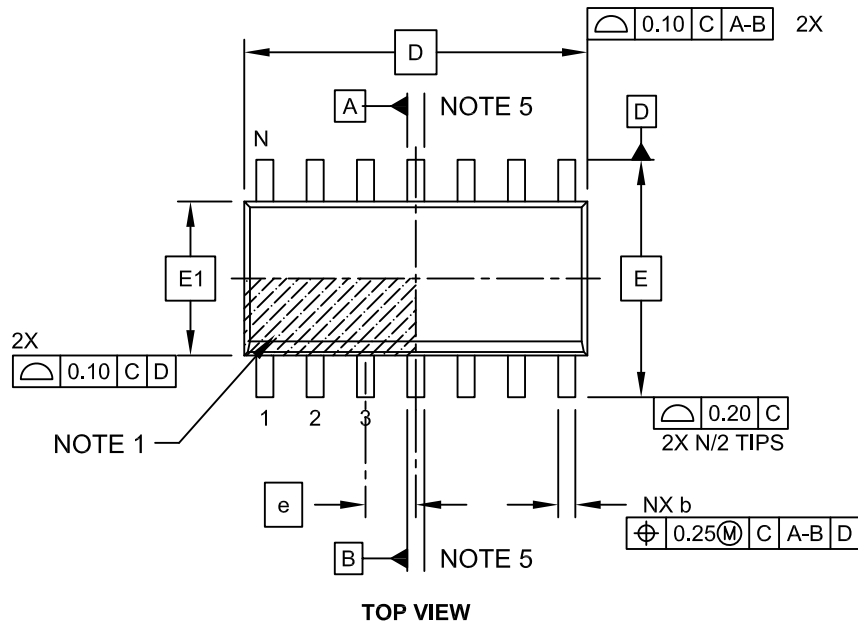

Microchip Technology Drawing No. C04-065C Sheet 1 of 2

MCP2221A

14-Lead Plastic Small Outline (SL) - Narrow, 3.90 mm Body [SOIC]

Note: For the most current package drawings, please see the Microchip Packaging Specification located at <http://www.microchip.com/packageing>

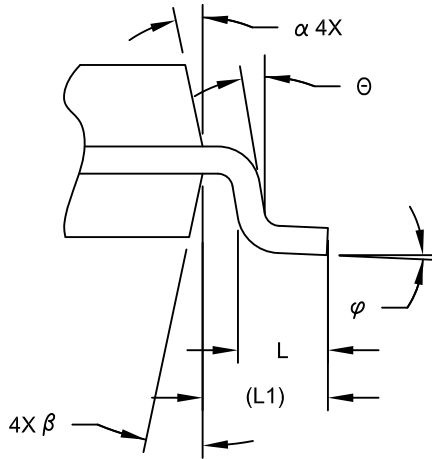

VIEW C

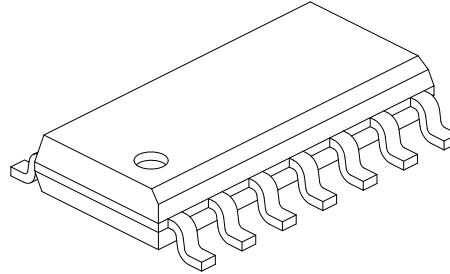

Dimension Limits	Units	MILLIMETERS		
		MIN	NOM	MAX
Number of Pins	N	14		
Pitch	e	1.27 BSC		
Overall Height	A	-	-	1.75
Molded Package Thickness	A2	1.25	-	-
Standoff §	A1	0.10	-	0.25
Overall Width	E	6.00 BSC		
Molded Package Width	E1	3.90 BSC		
Overall Length	D	8.65 BSC		
Chamfer (Optional)	h	0.25	-	0.50
Foot Length	L	0.40	-	1.27
Footprint	L1	1.04 REF		
Lead Angle	Θ	0°	-	-
Foot Angle	φ	0°	-	8°
Lead Thickness	c	0.10	-	0.25
Lead Width	b	0.31	-	0.51
Mold Draft Angle Top	α	5°	-	15°
Mold Draft Angle Bottom	β	5°	-	15°

Notes:

- Pin 1 visual index feature may vary, but must be located within the hatched area.
- § Significant Characteristic
- Dimension D does not include mold flash, protrusions or gate burrs, which shall not exceed 0.15 mm per end. Dimension E1 does not include interlead flash or protrusion, which shall not exceed 0.25 mm per side.
- Dimensioning and tolerancing per ASME Y14.5M
 BSC: Basic Dimension. Theoretically exact value shown without tolerances.
 REF: Reference Dimension, usually without tolerance, for information purposes only.
- Datums A & B to be determined at Datum H.

Microchip Technology Drawing No. C04-065C Sheet 2 of 2

14-Lead Plastic Small Outline (SL) - Narrow, 3.90 mm Body [SOIC]

Note: For the most current package drawings, please see the Microchip Packaging Specification located at <http://www.microchip.com/packaging>

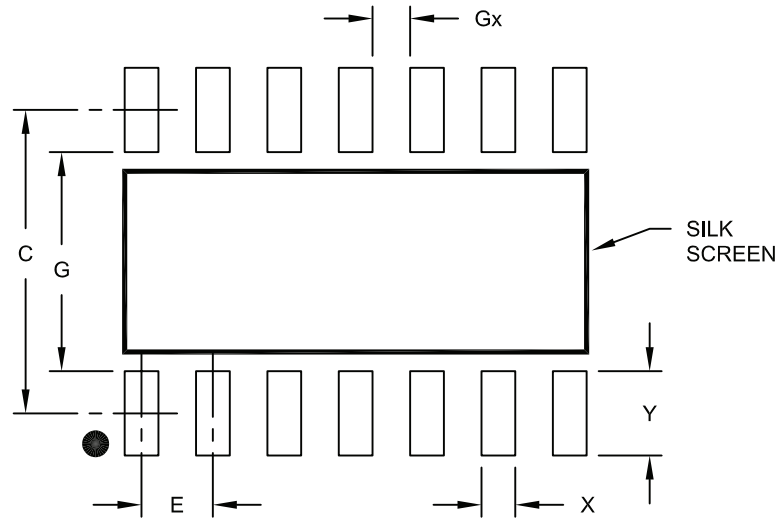

RECOMMENDED LAND PATTERN

Dimension Limits	Units	MILLIMETERS		
		MIN	NOM	MAX
Contact Pitch	E	1.27 BSC		
Contact Pad Spacing	C		5.40	
Contact Pad Width	X			0.60
Contact Pad Length	Y			1.50
Distance Between Pads	Gx	0.67		
Distance Between Pads	G	3.90		

Notes:

1. Dimensioning and tolerancing per ASME Y14.5M

BSC: Basic Dimension. Theoretically exact value shown without tolerances.

Microchip Technology Drawing No. C04-2065A

MCP2221A

14-Lead Plastic Thin Shrink Small Outline (ST) - 4.4 mm Body [TSSOP]

Note: For the most current package drawings, please see the Microchip Packaging Specification located at <http://www.microchip.com/packaging>

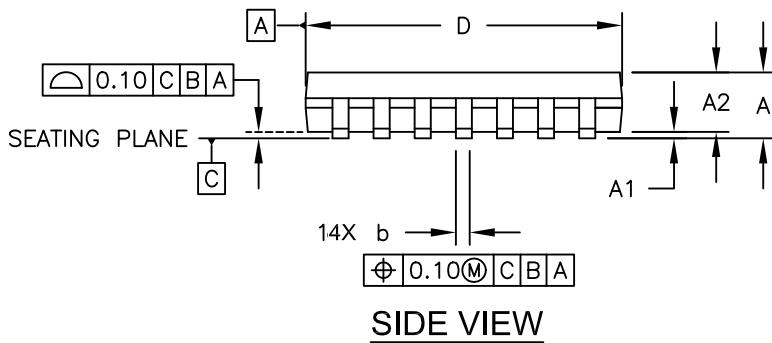
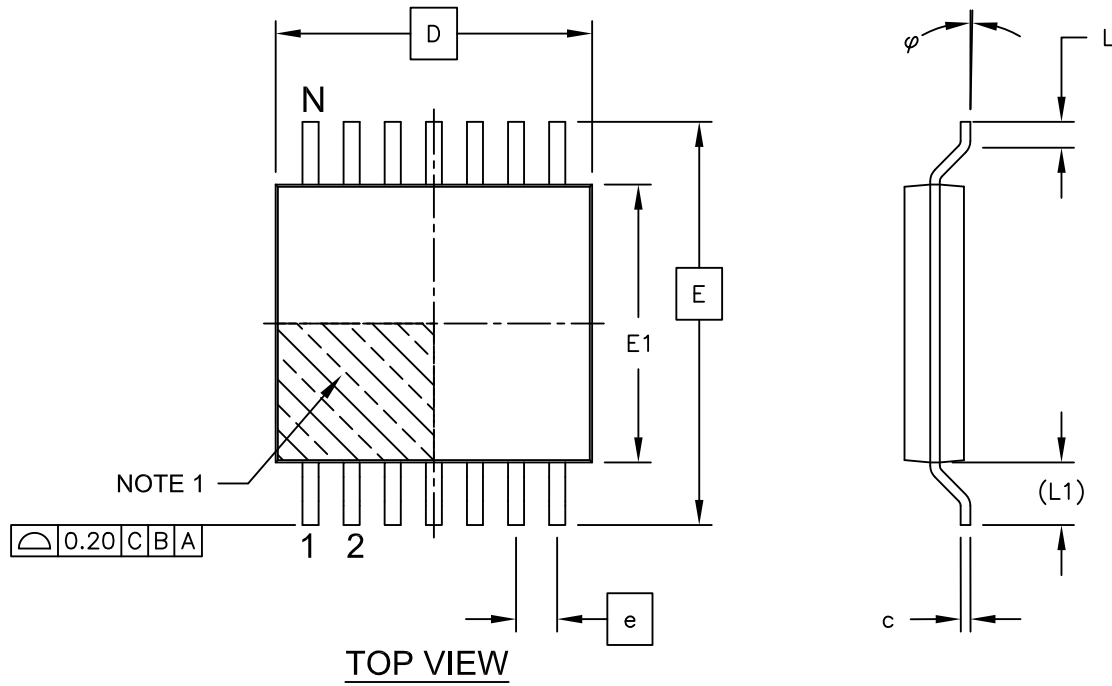

Microchip Technology Drawing C04-087C Sheet 1 of 2

14-Lead Plastic Thin Shrink Small Outline (ST) - 4.4 mm Body [TSSOP]

Note: For the most current package drawings, please see the Microchip Packaging Specification located at <http://www.microchip.com/packaging>

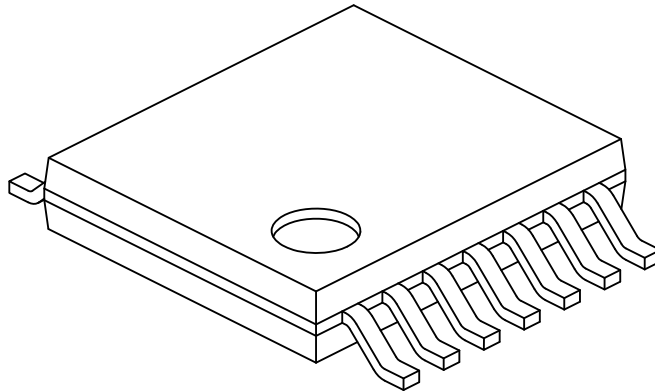

Dimension Limits	Units	MILLIMETERS		
		MIN	NOM	MAX
Number of Pins	N	14		
Pitch	e	0.65 BSC		
Overall Height	A	-	-	1.20
Molded Package Thickness	A2	0.80	1.00	1.05
Standoff	A1	0.05	-	0.15
Overall Width	E	6.40 BSC		
Molded Package Width	E1	4.30	4.40	4.50
Molded Package Length	D	4.90	5.00	5.10
Foot Length	L	0.45	0.60	0.75
Footprint	(L1)	1.00 REF		
Foot Angle	φ	0°	-	8°
Lead Thickness	c	0.09	-	0.20
Lead Width	b	0.19	-	0.30

Notes:

- Pin 1 visual index feature may vary, but must be located within the hatched area.
- Dimensions D and E1 do not include mold flash or protrusions. Mold flash or protrusions shall not exceed 0.15mm per side.
- Dimensioning and tolerancing per ASME Y14.5M

BSC: Basic Dimension. Theoretically exact value shown without tolerances.

REF: Reference Dimension, usually without tolerance, for information purposes only.

Microchip Technology Drawing No. C04-087C Sheet 2 of 2

MCP2221A

14-Lead Plastic Thin Shrink Small Outline (ST) - 4.4 mm Body [TSSOP]

Note: For the most current package drawings, please see the Microchip Packaging Specification located at <http://www.microchip.com/packaging>

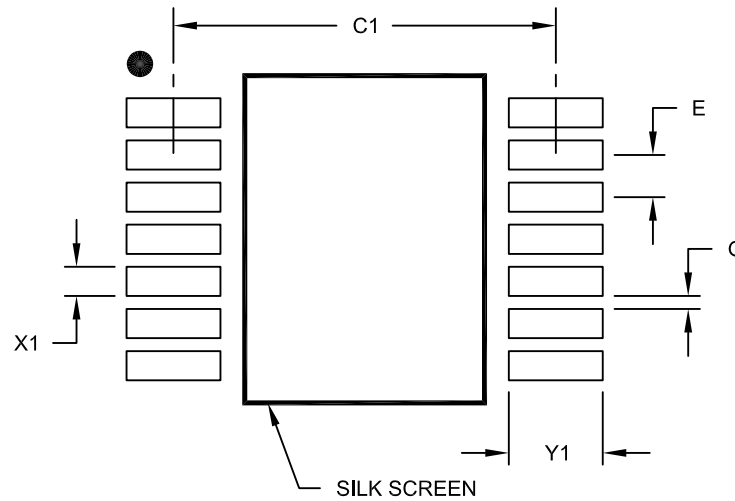

RECOMMENDED LAND PATTERN

Dimension Limits	Units	MILLIMETERS		
		MIN	NOM	MAX
Contact Pitch	E	0.65 BSC		
Contact Pad Spacing	C1		5.90	
Contact Pad Width (X14)	X1			0.45
Contact Pad Length (X14)	Y1			1.45
Distance Between Pads	G	0.20		

Notes:

1. Dimensioning and tolerancing per ASME Y14.5M

BSC: Basic Dimension. Theoretically exact value shown without tolerances.

Microchip Technology Drawing No. C04-2087A

16-Lead Plastic Quad Flat, No Lead Package (ML) - 4x4x0.9mm Body [QFN]

Note: For the most current package drawings, please see the Microchip Packaging Specification located at <http://www.microchip.com/packaging>

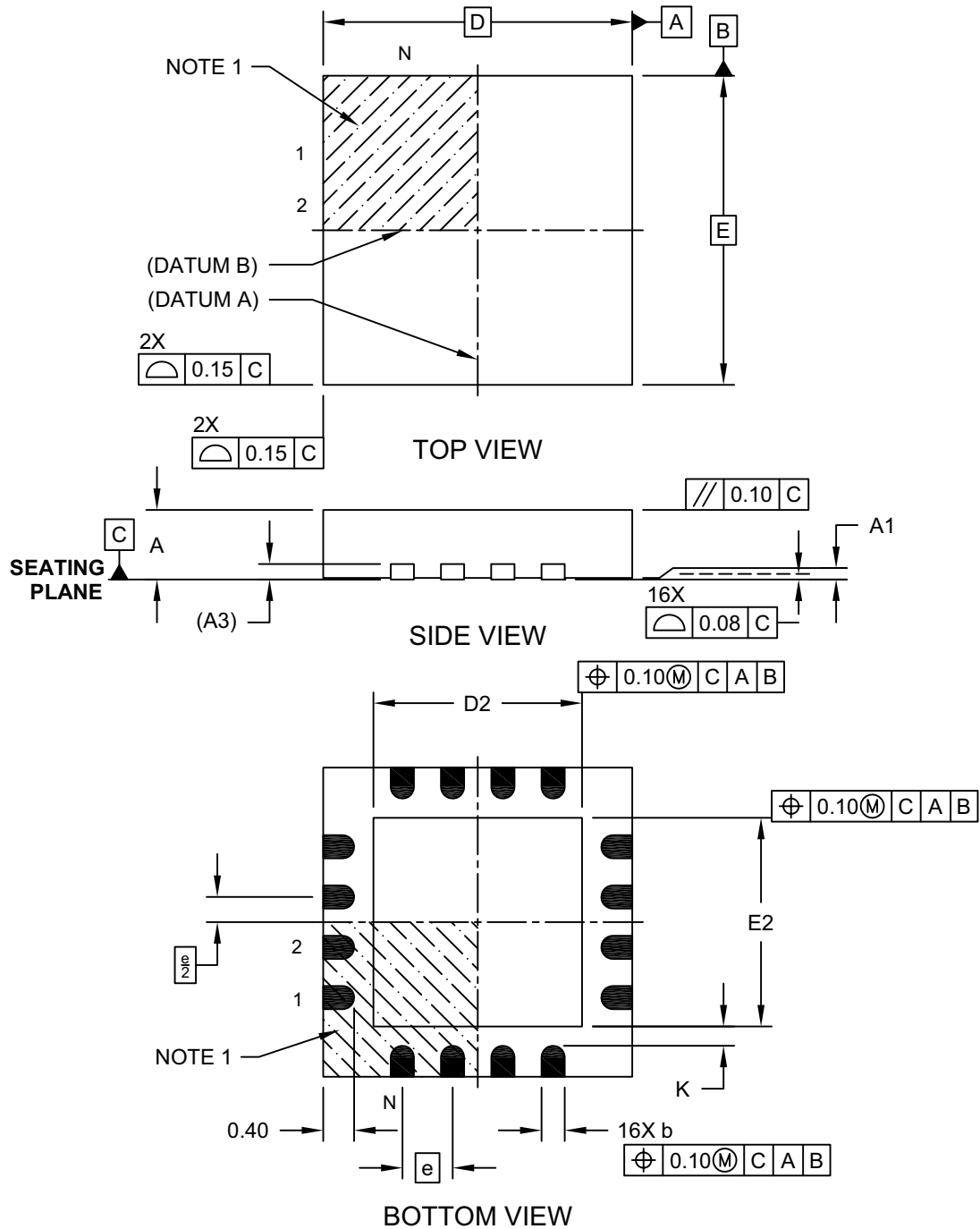

Microchip Technology Drawing C04-127D Sheet 1 of 2

MCP2221A

16-Lead Plastic Quad Flat, No Lead Package (ML) - 4x4x0.9mm Body [QFN]

Note: For the most current package drawings, please see the Microchip Packaging Specification located at <http://www.microchip.com/packaging>

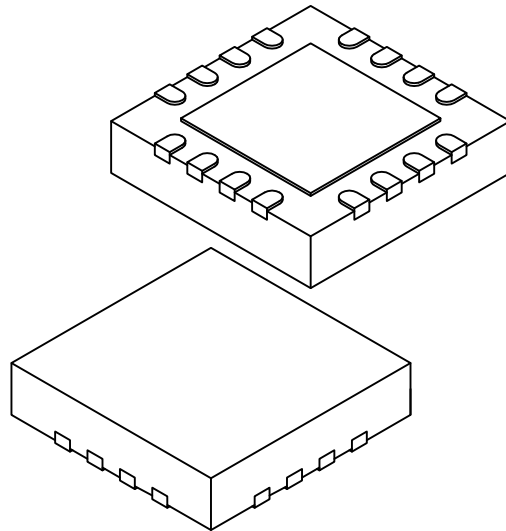

Dimension Limits	Units	MILLIMETERS		
		MIN	NOM	MAX
Number of Pins	N	16		
Pitch	e	0.65 BSC		
Overall Height	A	0.80	0.90	1.00
Standoff	A1	0.00	0.02	0.05
Contact Thickness	A3	0.20 REF		
Overall Width	E	4.00 BSC		
Exposed Pad Width	E2	2.50	2.65	2.80
Overall Length	D	4.00 BSC		
Exposed Pad Length	D2	2.50	2.65	2.80
Contact Width	b	0.25	0.30	0.35
Contact Length	L	0.30	0.40	0.50
Contact-to-Exposed Pad	K	0.20	-	-

Notes:

1. Pin 1 visual index feature may vary, but must be located within the hatched area.
2. Package is saw singulated
3. Dimensioning and tolerancing per ASME Y14.5M
 - BSC: Basic Dimension. Theoretically exact value shown without tolerances.
 - REF: Reference Dimension, usually without tolerance, for information purposes only.

Microchip Technology Drawing C04-127D Sheet 2 of 2

16-Lead Plastic Quad Flat, No Lead Package (ML) - 4x4x0.9mm Body [QFN]

Note: For the most current package drawings, please see the Microchip Packaging Specification located at <http://www.microchip.com/packaging>

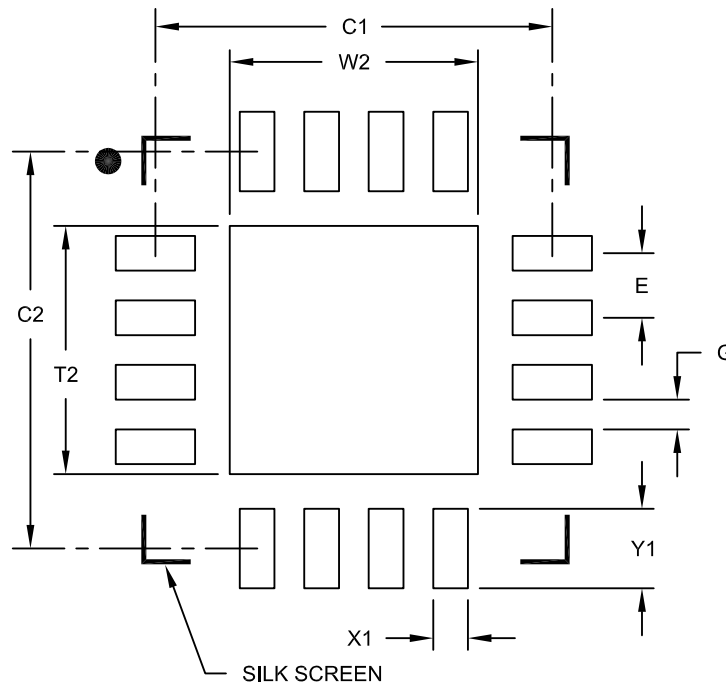

RECOMMENDED LAND PATTERN

Dimension Limits	Units	MILLIMETERS		
		MIN	NOM	MAX
Contact Pitch	E	0.65 BSC		
Optional Center Pad Width	W2			2.50
Optional Center Pad Length	T2			2.50
Contact Pad Spacing	C1		4.00	
Contact Pad Spacing	C2		4.00	
Contact Pad Width (X16)	X1			0.35
Contact Pad Length (X16)	Y1			0.80
Distance Between Pads	G	0.30		

Notes:

1. Dimensioning and tolerancing per ASME Y14.5M

BSC: Basic Dimension. Theoretically exact value shown without tolerances.

Microchip Technology Drawing No. C04-2127A

MCP2221A

NOTES:

APPENDIX A: REVISION HISTORY

Revision C (June 2020)

The following is the list of modifications:

- Updated description of [Register 1-1](#).
- Added [Figure 1-8](#).
- Clarified [Table 3-2](#) byte 8 as “don’t care”.
- Made minor typographical edits.

Revision B (July 2017)

The following is the list of modifications:

- Added [Table 4-2](#) and [Table 4-3](#).
- Made minor typographical edits.

Revision A (June 2016)

- Original release of this document.

MCP2221A

NOTES:

PRODUCT IDENTIFICATION SYSTEM

To order or obtain information, e.g., on pricing or delivery, contact your local Microchip sales office.

<u>PART NO.</u>	<u>IXI⁽¹⁾</u>	<u>X</u>	<u>XX</u>	
Device	Tape and Reel Option	Temperature Range	Package	
<p>Device: MCP2221A: USB-to-I²C/UART Protocol Converter MCP2221AT: USB-to-I²C/UART Protocol Converter (Tape and Reel)</p> <p>Temperature Range: I = -40°C to +85°C (Industrial)</p> <p>Package: ML = Plastic Quad Flat, No Lead Package – 4x4x0.9 mm Body (QFN), 16-Lead P = Plastic Dual In Line, 300 mil. Body (PDIP), 14-Lead SL = Plastic Small Outline – Narrow, 3.90 mm Body (SOIC), 14-Lead ST = Plastic Thin Shrink Small Outline – 4.4 mm Body (TSSOP), 14-Lead</p> <p>Note 1: Tape and Reel identifier only appears in the catalog part number description. This identifier is used for ordering purposes and is not printed on the device package. Check with your Microchip Sales Office for package availability with the Tape and Reel option.</p>				
				<p>Examples:</p> <p>a) MCP2221A- I/P: Industrial temperature, 14LD PDIP Package</p> <p>a) MCP2221A- I/SL: Industrial temperature, 14LD SOIC Package</p> <p>b) MCP2221AT- I/SL: Tape and Reel, Industrial temperature, 14LD SOIC Package</p> <p>a) MCP2221A- I/ST: Industrial temperature, 14LD TSSOP Package</p> <p>b) MCP2221AT- I/ST: Tape and Reel, Industrial temperature, 14LD TSSOP Package</p> <p>a) MCP2221A- I/ML: Industrial temperature, 16LD 4x4 QFN Package</p> <p>b) MCP2221AT- I/ML: Tape and Reel, Industrial temperature, 16LD 4x4 QFN Package</p>

MCP2221A

NOTES:

Note the following details of the code protection feature on Microchip devices:

- Microchip products meet the specification contained in their particular Microchip Data Sheet.
- Microchip believes that its family of products is one of the most secure families of its kind on the market today, when used in the intended manner and under normal conditions.
- There are dishonest and possibly illegal methods used to breach the code protection feature. All of these methods, to our knowledge, require using the Microchip products in a manner outside the operating specifications contained in Microchip's Data Sheets. Most likely, the person doing so is engaged in theft of intellectual property.
- Microchip is willing to work with the customer who is concerned about the integrity of their code.
- Neither Microchip nor any other semiconductor manufacturer can guarantee the security of their code. Code protection does not mean that we are guaranteeing the product as “unbreakable.”

Code protection is constantly evolving. We at Microchip are committed to continuously improving the code protection features of our products. Attempts to break Microchip's code protection feature may be a violation of the Digital Millennium Copyright Act. If such acts allow unauthorized access to your software or other copyrighted work, you may have a right to sue for relief under that Act.

Information contained in this publication regarding device applications and the like is provided only for your convenience and may be superseded by updates. It is your responsibility to ensure that your application meets with your specifications. MICROCHIP MAKES NO REPRESENTATIONS OR WARRANTIES OF ANY KIND WHETHER EXPRESS OR IMPLIED, WRITTEN OR ORAL, STATUTORY OR OTHERWISE, RELATED TO THE INFORMATION, INCLUDING BUT NOT LIMITED TO ITS CONDITION, QUALITY, PERFORMANCE, MERCHANTABILITY OR FITNESS FOR PURPOSE. Microchip disclaims all liability arising from this information and its use. Use of Microchip devices in life support and/or safety applications is entirely at the buyer's risk, and the buyer agrees to defend, indemnify and hold harmless Microchip from any and all damages, claims, suits, or expenses resulting from such use. No licenses are conveyed, implicitly or otherwise, under any Microchip intellectual property rights unless otherwise stated.

Trademarks

The Microchip name and logo, the Microchip logo, Adaptec, AnyRate, AVR, AVR logo, AVR Freaks, BesTime, BitCloud, chipKIT, chipKIT logo, CryptoMemory, CryptoRF, dsPIC, FlashFlex, flexPWR, HELDO, IGLoo, JukeBlox, KeeLoq, Klear, LANCheck, LinkMD, maXStylus, maXTouch, MediaLB, megaAVR, Microsemi, Microsemi logo, MOST, MOST logo, MPLAB, OptoLyzer, PackeTime, PIC, picoPower, PICSTART, PIC32 logo, PolarFire, Prochip Designer, QTouch, SAM-BA, SenGenuity, SpyNIC, SST, SST Logo, SuperFlash, Symmetricom, SyncServer, Tachyon, TempTracker, TimeSource, tinyAVR, UNI/O, Vectron, and XMEGA are registered trademarks of Microchip Technology Incorporated in the U.S.A. and other countries.

APT, ClockWorks, The Embedded Control Solutions Company, EtherSynch, FlashTec, Hyper Speed Control, HyperLight Load, IntelliMOS, Libero, motorBench, mTouch, Powermite 3, Precision Edge, ProASIC, ProASIC Plus, ProASIC Plus logo, Quiet-Wire, SmartFusion, SyncWorld, Temux, TimeCesium, TimeHub, TimePictra, TimeProvider, Vite, WinPath, and ZL are registered trademarks of Microchip Technology Incorporated in the U.S.A.

Adjacent Key Suppression, AKS, Analog-for-the-Digital Age, Any Capacitor, AnyIn, AnyOut, BlueSky, BodyCom, CodeGuard, CryptoAuthentication, CryptoAutomotive, CryptoCompanion, CryptoController, dsPICDEM, dsPICDEM.net, Dynamic Average Matching, DAM, ECAN, EtherGREEN, In-Circuit Serial Programming, ICSP, INICnet, Inter-Chip Connectivity, JitterBlocker, KlearNet, KlearNet logo, memBrain, Mindi, MiWi, MPASM, MPF, MPLAB Certified logo, MPLIB, MPLINK, MultiTRAK, NetDetach, Omniscient Code Generation, PICDEM, PICDEM.net, PICKit, PICtail, PowerSmart, PureSilicon, QMatrix, REAL ICE, Ripple Blocker, SAM-ICE, Serial Quad I/O, SMART-I.S., SQI, SuperSwitcher, SuperSwitcher II, Total Endurance, TSHARC, USBCheck, VariSense, ViewSpan, WiperLock, Wireless DNA, and ZENA are trademarks of Microchip Technology Incorporated in the U.S.A. and other countries.

SQTP is a service mark of Microchip Technology Incorporated in the U.S.A.

The Adaptec logo, Frequency on Demand, Silicon Storage Technology, and Symmcom are registered trademarks of Microchip Technology Inc. in other countries.

GestIC is a registered trademark of Microchip Technology Germany II GmbH & Co. KG, a subsidiary of Microchip Technology Inc., in other countries.

All other trademarks mentioned herein are property of their respective companies.

© 2016-2020, Microchip Technology Incorporated, All Rights Reserved.

ISBN: 978-1-5224-6224-8

For information regarding Microchip's Quality Management Systems, please visit www.microchip.com/quality.



MICROCHIP

Worldwide Sales and Service

AMERICAS

Corporate Office
2355 West Chandler Blvd.
Chandler, AZ 85224-6199
Tel: 480-792-7200
Fax: 480-792-7277
Technical Support:
<http://www.microchip.com/support>
Web Address:
www.microchip.com

Atlanta

Duluth, GA
Tel: 678-957-9614
Fax: 678-957-1455

Austin, TX

Tel: 512-257-3370

Boston

Westborough, MA
Tel: 774-760-0087
Fax: 774-760-0088

Chicago

Itasca, IL
Tel: 630-285-0071
Fax: 630-285-0075

Dallas

Addison, TX
Tel: 972-818-7423
Fax: 972-818-2924

Detroit

Novi, MI
Tel: 248-848-4000

Houston, TX

Tel: 281-894-5983

Indianapolis

Noblesville, IN
Tel: 317-773-8323
Fax: 317-773-5453
Tel: 317-536-2380

Los Angeles

Mission Viejo, CA
Tel: 949-462-9523
Fax: 949-462-9608
Tel: 951-273-7800

Raleigh, NC

Tel: 919-844-7510

New York, NY

Tel: 631-435-6000

San Jose, CA

Tel: 408-735-9110
Tel: 408-436-4270

Canada - Toronto

Tel: 905-695-1980
Fax: 905-695-2078

ASIA/PACIFIC

Australia - Sydney
Tel: 61-2-9868-6733

China - Beijing
Tel: 86-10-8569-7000

China - Chengdu
Tel: 86-28-8665-5511

China - Chongqing
Tel: 86-23-8980-9588

China - Dongguan
Tel: 86-769-8702-9880

China - Guangzhou
Tel: 86-20-8755-8029

China - Hangzhou
Tel: 86-571-8792-8115

China - Hong Kong SAR
Tel: 852-2943-5100

China - Nanjing
Tel: 86-25-8473-2460

China - Qingdao
Tel: 86-532-8502-7355

China - Shanghai
Tel: 86-21-3326-8000

China - Shenyang
Tel: 86-24-2334-2829

China - Shenzhen
Tel: 86-755-8864-2200

China - Suzhou
Tel: 86-186-6233-1526

China - Wuhan
Tel: 86-27-5980-5300

China - Xian
Tel: 86-29-8833-7252

China - Xiamen
Tel: 86-592-2388138

China - Zhuhai
Tel: 86-756-3210040

ASIA/PACIFIC

India - Bangalore
Tel: 91-80-3090-4444

India - New Delhi
Tel: 91-11-4160-8631

India - Pune
Tel: 91-20-4121-0141

Japan - Osaka
Tel: 81-6-6152-7160

Japan - Tokyo
Tel: 81-3-6880-3770

Korea - Daegu
Tel: 82-53-744-4301

Korea - Seoul
Tel: 82-2-554-7200

Malaysia - Kuala Lumpur
Tel: 60-3-7651-7906

Malaysia - Penang
Tel: 60-4-227-8870

Philippines - Manila
Tel: 63-2-634-9065

Singapore
Tel: 65-6334-8870

Taiwan - Hsin Chu
Tel: 886-3-577-8366

Taiwan - Kaohsiung
Tel: 886-7-213-7830

Taiwan - Taipei
Tel: 886-2-2508-8600

Thailand - Bangkok
Tel: 66-2-694-1351

Vietnam - Ho Chi Minh
Tel: 84-28-5448-2100

EUROPE

Austria - Wels
Tel: 43-7242-2244-39
Fax: 43-7242-2244-393

Denmark - Copenhagen
Tel: 45-4485-5910
Fax: 45-4485-2829

Finland - Espoo
Tel: 358-9-4520-820

France - Paris
Tel: 33-1-69-53-63-20
Fax: 33-1-69-30-90-79

Germany - Garching
Tel: 49-8931-9700

Germany - Haan
Tel: 49-2129-3766400

Germany - Heilbronn
Tel: 49-7131-72400

Germany - Karlsruhe
Tel: 49-721-625370

Germany - Munich
Tel: 49-89-627-144-0
Fax: 49-89-627-144-44

Germany - Rosenheim
Tel: 49-8031-354-560

Israel - Ra'anana
Tel: 972-9-744-7705

Italy - Milan
Tel: 39-0331-742611
Fax: 39-0331-466781

Italy - Padova
Tel: 39-049-7625286

Netherlands - Drunen
Tel: 31-416-690399
Fax: 31-416-690340

Norway - Trondheim
Tel: 47-7288-4388

Poland - Warsaw
Tel: 48-22-3325737

Romania - Bucharest
Tel: 40-21-407-87-50

Spain - Madrid
Tel: 34-91-708-08-90
Fax: 34-91-708-08-91

Sweden - Gothenberg
Tel: 46-31-704-60-40

Sweden - Stockholm
Tel: 46-8-5090-4654

UK - Wokingham
Tel: 44-118-921-5800
Fax: 44-118-921-5820