



HESTORE.HU

elektronikai alkatrész áruház

EN: This Datasheet is presented by the manufacturer.

Please visit our website for pricing and availability at www.hestore.hu.

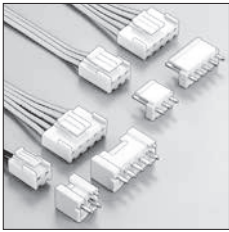

VH CONNECTOR

3.96 mm pitch/Wire-to-Board connectors/Crimp style and Mating style

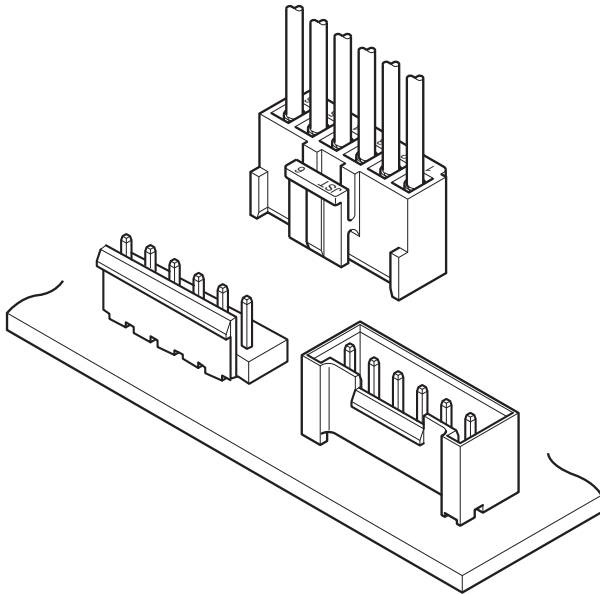

This wire-to-board connector with a 3.96 mm pitch is commonly used in power supply circuits for a wide variety of electrical and electronic devices. It supports currents up to 10 A.

- **Compact size, high current capability**
Compact design with a mounting height of 16.5 mm and a depth of 10.5 mm (for top-entry type), combined with a high current rating of 10 A (when using AWG #16 wire).
- **Box-shaped leaf spring contact**
The contact is highly reliable, featuring a leaf-shaped design with excellent spring characteristics housed within a box.
- **Secure lock mechanism**
The large, highly visible outer-type housing with a strong lock ensures easy and secure insertion and removal. Additionally, it offers excellent mechanical reliability in the mated condition.

■ Specifications

- Current rating: 10 A AC/DC
 - *When using AWG #16 with the standard type header.
7A AC/DC
 - *When using AWG #18 with the shrouded type header.
- Note: Do not branch in parallel current which exceeds the rated current. If branched in parallel, current imbalance or other problems may occur. If it is absolutely necessary to branch such a large current in parallel, design the circuits without causing any imbalance and provide extra margin for each circuit.
- Voltage rating: 250 V AC/DC
- Temperature range: -40°C to +105°C
(including temperature rise in applying electrical current)
- Contact resistance: Initial value/ 10 mΩ max.
After test/ 20 mΩ max.
- Insulation resistance: 1,000 MΩ min.
- Withstanding voltage:
There shall be no breakdown or flashover while applying 1,500 VAC for one minute.
- Applicable wire range:
Conductor size/ AWG #22 to AWG #16
Insulation O.D./ ϕ 1.7 mm to ϕ 3.0 mm
- Applicable PC board thickness: 1.6 mm
- * Please refer to the "Handling Precautions for Terminals and Connectors" on our website (listed in the "Technical Documents" column on the Product Information page) before use.
- * RoHS2 compliance
- * Dimensional unit: mm
- * Contact JST for details.

■ Standards

For information on overseas standard registrations, please refer to the "List of Registered Overseas Standards" on our website (listed in the "Technical Documents" column on the Product Information page).

- * Specifications registered to overseas standards may differ from the general specifications listed above.

VH CONNECTOR

Contact

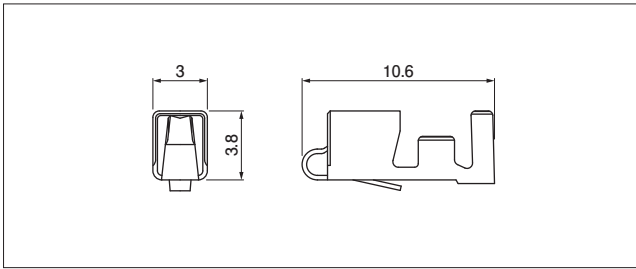

Model No.	Applicable wire range		Q'ty/ reel
	Conductor size AWG (mm ²)	Insulation O.D. (mm)	
SVH-21T-P1.1	#22 to #18 (0.33 to 0.83)	1.7 to 3.0	4,500
SVH-41T-P1.1	#20 to #16 (0.5 to 1.25)	1.7 to 3.0	3,500

Material and Surface finish, etc.

Copper alloy, tin-plated

Note: When using the retainer mountable type housing, the applicable wire insulation outer diameter is ϕ 1.7 to ϕ 2.2.

Crimping machine

Contact	Crimping machine	Applicator	Crimp applicator with dies
SVH-21T-P1.1	AP-K2N	MKS-L	APLMK SVH21-11
SVH-41T-P1.1			APLMK SVH41-11

Note: Contact JST for fully automatic crimping applicator.

Housing

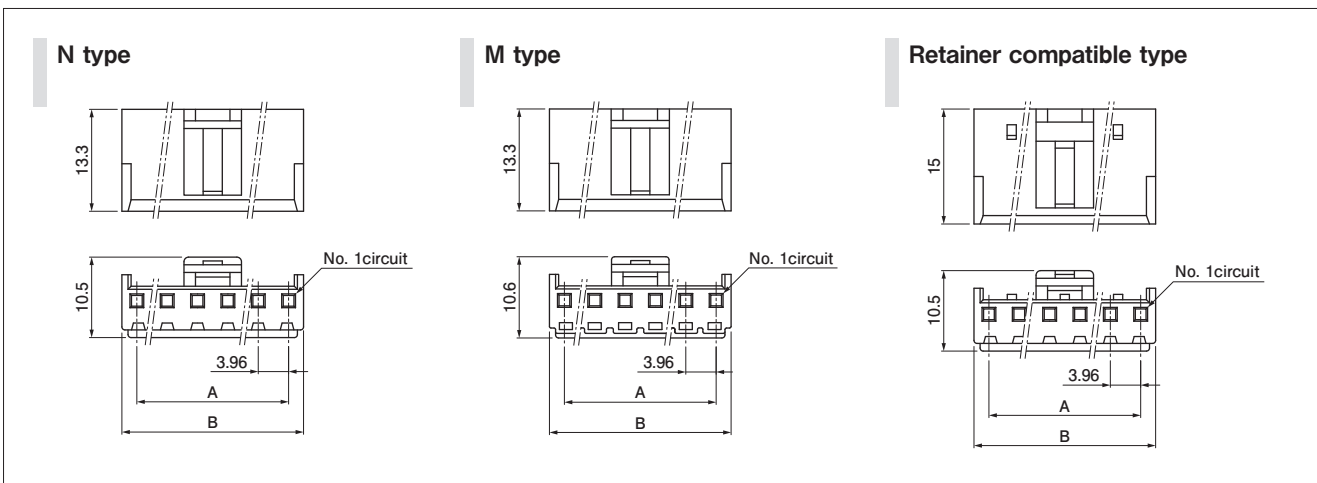

No. of circuits	Model No.			Dimensions (mm)		Q'ty/bag	
	N type	M type	Retainer compatible type	A	B	N type M type	Retainer compatible type
2	VHR-2N	VHR-2M	VHRR-2N ^{Note 2}	3.96	7.86	1,000	1,000
3	VHR-3N	VHR-3M	VHRR-3N	7.92	11.82	1,000	500
4	VHR-4N	VHR-4M	—	11.88	15.78	1,000	1,000
5	VHR-5N	VHR-5M	VHRR-5N	15.84	19.74	1,000	500
6	VHR-6N	VHR-6M	—	19.80	23.70	500	500
7	VHR-7N	VHR-7M	VHRR-7N	23.76	27.66	500	500
8	VHR-8N	—	VHRR-8N	27.72	31.62	500	500
9	VHR-9N	VHR-9M	VHRR-9N	31.68	35.58	500	500
10	VHR-10N	—	—	35.64	39.54	500	500
11	VHR-11N	—	—	39.60	43.50	500	500

Material and Surface finish, etc.

PA, natural (white)

- Note: 1. With the M type, the exposed contact lances from the N type are covered by resin which is integrally formed and molded into the housing body as a single unit, further improving electrical safety.
2. Please note that the retainer mountable type housing for 2 circuits can only be used with the standard type header. It cannot be used with the shrouded type header.
3. For flame retardant grade of resin material used, please refer to the "List of Registered Overseas Standards" on our website (listed in the "Technical Documents" column on the Product Information page).

VH CONNECTOR

Retainer

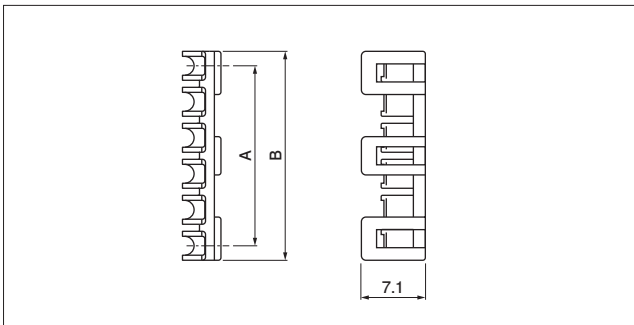

No. of circuits	Model No.	Dimensions (mm)		Q'ty/bag
		A	B	
2	VHS-2V	3.7	6.9	1,000
3	VHS-3V	7.52	10.72	1,000
5	VHS-5V	15.44	18.64	1,000
7	VHS-7V	23.36	26.56	1,000
8	VHS-8V	27.32	30.52	1,000
9	VHS-9V	31.28	34.48	1,000

Material and Surface finish, etc.

PA (GF), natural (ivory)

Note: For flame retardant grade of resin material used, please refer to the "List of Registered Overseas Standards" on our website (listed in the "Technical Documents" column on the Product Information page).

Header (Standard type)

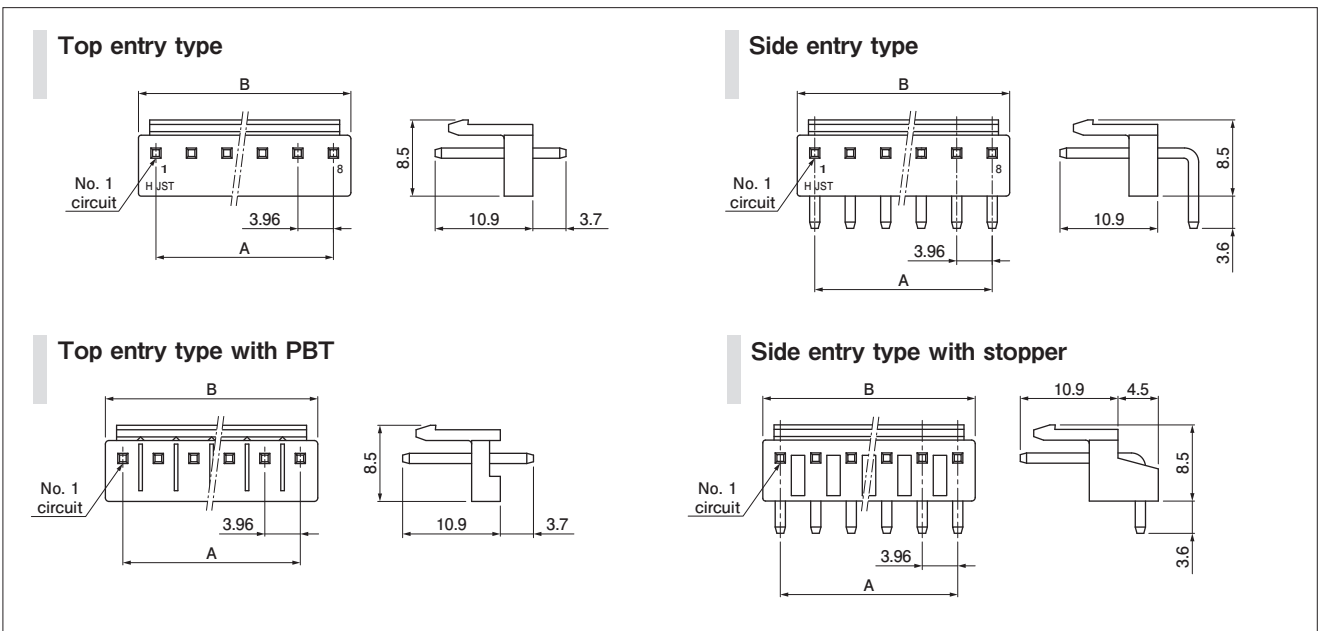

No. of circuits	Model No.				Dimensions (mm)		Q'ty/box	
	Top entry type ^{Note2}	Side entry type ^{Note2}	Top entry type with PBT	Side entry type with stopper	A	B	Top entry type	Side entry type
2	B2P-VH	B2PS-VH	B2P-VH-B	S2P-VH	3.96	7.86	1,000	1,000
3	B3P-VH	B3PS-VH	B3P-VH-B	S3P-VH	7.92	11.82	1,000	500
4	B4P-VH	B4PS-VH	B4P-VH-B	S4P-VH	11.88	15.78	500	500
5	B5P-VH	B5PS-VH	B5P-VH-B	S5P-VH	15.84	19.74	500	250
6	B6P-VH	B6PS-VH	B6P-VH-B	S6P-VH	19.80	23.70	250	250
7	B7P-VH	B7PS-VH	B7P-VH-B	S7P-VH	23.76	27.66	250	250
8	B8P-VH	B8PS-VH	B8P-VH-B	—	27.72	31.62	200	200
9	B9P-VH	B9PS-VH	B9P-VH-B	—	31.68	35.58	200	200
10	B10P-VH	B10PS-VH	B10P-VH-B	—	35.64	39.54	200	100
11	—	—	B11P-VH-B	—	39.60	43.50	200	—

Material and Surface finish, etc.

Post: Copper alloy, tin-plated
 Base housing: Non-PBT/ PA, natural (white)
 PBT/ PBT (GF), natural (white)

Note: 1. This product displays (LF)(SN) on a label.

2. Headers with posts omitted are also available. Please contact JST for further details.

3. For flame retardant grade of resin material used, please refer to the "List of Registered Overseas Standards" on our website (listed in the "Technical Documents" column on the Product Information page).

VH CONNECTOR

Header (Shrouded Header)

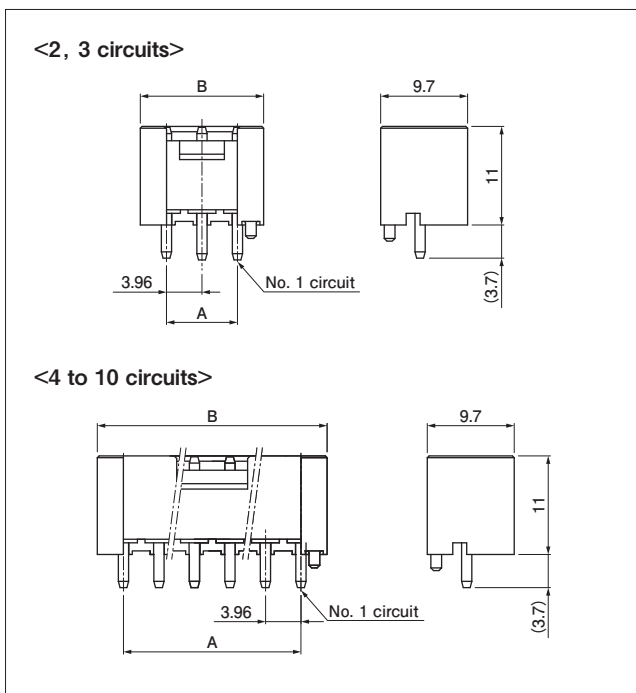

No. of circuits	Model No.	Dimensions (mm)		Q'ty/box
		A	B	
2	B2P-VH-FB-B ^{Note2}	3.96	9.8	250
3	B3P-VH-FB-B	7.92	13.76	200
4	B4P-VH-FB-B	11.88	17.72	150
5	B5P-VH-FB-B	15.84	21.68	200
6	B6P-VH-FB-B	19.80	25.64	200
7	B7P-VH-FB-B	23.76	29.60	100
8	B8P-VH-FB-B	27.72	33.56	100
9	B9P-VH-FB-B	31.68	37.52	100
10	B10P-VH-FB-B	35.64	41.48	125

Material and Surface finish, etc.

Post: Copper alloy, tin-plated
Base housing: PBT (GF), natural (white)

- Note: 1. This product displays (LF)(SN) on a label.
2. The housings that mate with the two position are the N-type and M-type.
Please note that retainer mountable type cannot be used.
3. For flame retardant grade of resin material used, please refer to the "List of Registered Overseas Standards" on our website (listed in the "Technical Documents" column on the Product Information page).

PC board layout and Assembly layout

Top entry type

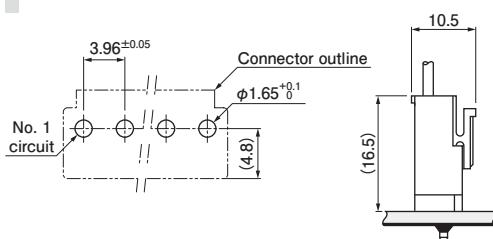

Side entry type

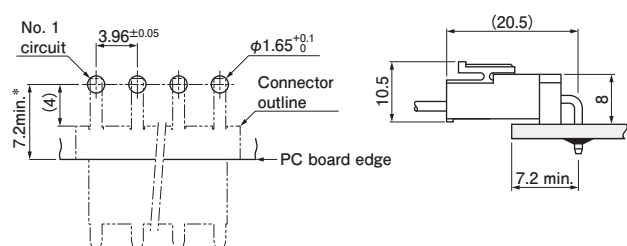

* 11.0 max when used with the VR connector socket

Side entry type with stopper

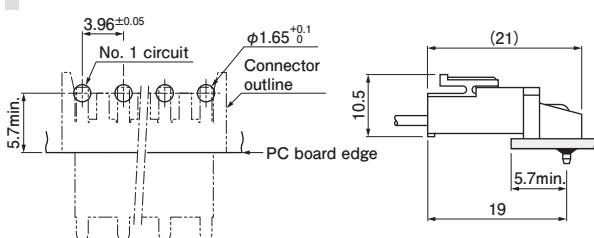

Shrouded Header

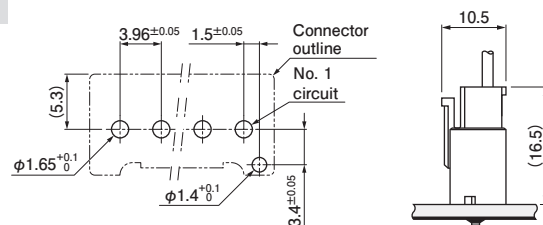

- Note: 1. The PC board layout figure shown is viewed from the connector mounting surface.
2. Tolerance for the PCB hole pitch shall be ± 0.05 and shall not accumulate.
3. Hole dimensions differ depending on the type of PCB and PCB drilling method.
The above dimensions are for reference only. Please contact JST for further details.
4. The assembly layout is for N-type housings.
For housings other than N-type, please contact JST.

Model number allocation

Contact

S VH - 21 T - P 1.1

Supply form: S...Strip form
B...Loose piece

Series name

Applicable wire range:
21...AWG #22 to AWG #18
41...AWG #20 to AWG #16

Surface finish: Tin-plated

Material: Copper alloy

Applicable post size

Housing/ N type, M type

VH R - 2 N - ■

Series name

Type: For receptacle contact

No. of circuits

Shape: N...Contact lance exposed
M...Contact lance covered by resin

Color: No indication...Natural (White), BK...Black, R...Red,
BL...Blue, M...Green, D...Orange, Y...Yellow, PK...Pink,
H...Gray

Housing/ Retainer compatible type

VH R R - 2 N - ■

Series name

Type: For receptacle contact

Retainer compatible type

No. of circuits

Shape: Contact lance exposed

Color: No indication...Natural (White)

Retainer

VH S - 2 V

Series name

Type: Retainer

No. of circuits

Sub model number

Header (Standard type)

B 2P ■ - VH - ■

Assembly product

No. of circuits

Header type: No indication...Top entry type
S...Side entry type

Series name

Color: No indication...Natural (White), BK...Black, R...Red,
BL...Blue, M...Green, O...Orange, Y...Yellow, PK...Pink,
H...Gray, TR...Tomato red

Header (Standard type)/ Top entry type with PBT

B 2P - VH - B - ■

Assembly product

No. of circuits

Series name

Material: PBT (GF)

Color: No indication...Natural (White), C...Black, R...Red,
E...Blue, M...Green, Y...Yellow

Header (Standard type)/ Side entry type with stopper

S 2P - VH - ■

Header type: Side entry type with stopper

No. of circuits

Series name

Color: No indication...Natural (White), BK...Black,
Red, BL...Blue, M...Green, Y...Yellow

Header (Shrouded Header)

B 2P - VH - FB - B - ■

Assembly product

No. of circuits

Series name

Sub model number

Material: PBT (GF)

Color: No indication...Natural (White), C...Black, R...Red,
E...Blue, M...Green, O...Orange, Y...Yellow,
PK...Pink, H...Gray,

Model number allocation

Headers with posts omitted (standard type)

1) Polarized header (N-1) with post omitted

However, this only applies when 4 posts or more are used

B*1 P*2 -VH

Example)

Circuit No.	1	2	3	4	5	6	7
Circuit (post)	○	○	○	○	○	×	○
Model No.	B6P7-VH						

○: with post
×: without post

2) Polarized header with circuit No. 2 post omitted

However, this only applies when 4 posts or more are used

B*1 P*2 -VH-L

Example)

Circuit No.	1	2	3	4	5	6	7
Circuit (post)	○	×	○	○	○	○	○
Model No.	B6P7-VH-L						

○: with post
×: without post

3) Header with pitch size doubled by omitting even numbered posts

However, this only applies if the total number of circuits (including circuits without posts) is an odd number.

① Header with pitch size doubled (7.92 mm)

B*1 P*2 -VH

Example)

Circuit No.	1	2	3	4	5	6	7
Circuit (post)	○	×	○	×	○	×	○
Model No.	B4P7-VH						

○: with post
×: without post

② Header with pitch size tripled (11.88 mm)

B*1 P*2 -VH

Example)

Circuit No.	1	2	3	4	5	6	7
Circuit (post)	○	×	×	○	×	×	○
Model No.	B3P7-VH						

○: with post
×: without post

③ Header with pitch size quadrupled (15.84 mm)

B*1 P*2 -VH

Example)

Circuit No.	1	2	3	4	5	6	7	8	9
Circuit (post)	○	×	×	×	○	×	×	×	○
Model No.	B3P9-VH								

○: with post
×: without post

Note) *1: Actual number of circuits (actual number of posts)
*2: Total number of circuits (including post-omitted circuits)