



HESTORE.HU

elektronikai alkatrész áruház

EN: This Datasheet is presented by the manufacturer.

Please visit our website for pricing and availability at www.hestore.hu.

CD405xB CMOS Single 8-Channel Analog Multiplexer or Demultiplexer With Logic-Level Conversion

1 Features

- Wide range of digital and analog signal levels:
 - Digital: 3V to 20V
 - Analog: $\leq 20V_{P-P}$
- Single supply range : 3V to 20V (performance degrades for $V_{DD} < 3V$)
- Dual Supply range: $\pm 3V$ to $\pm 10V$
- Low ON resistance, 125 Ω (typical) over input range for $V_{DD} = 15V$
- Low channel leakage of $\pm 10pA$ (typical) at $V_{DD} = 15V$
- Low quiescent power dissipation : 0.2 μW (typical)
- Break-before-make switching eliminates channel overlap
- Bidirectional signal path
- ESD protection HBM: 3000V, CDM: 2000V
- Pin compatible with industry standard 4051 muxes

2 Applications

- Analog and digital multiplexing and demultiplexing
- Analog to digital and digital to analog conversion
- Signal gating
- [Factory automation](#)
- [Televisions](#)
- [Appliances](#)
- [Consumer audio](#)
- Programmable logic circuits
- [Sensors](#)

3 Description

The CD405xB analog multiplexers and demultiplexers are digitally-controlled analog switches having low ON impedance and very low OFF leakage current. These multiplexer circuits dissipate extremely low quiescent power over the full $V_{DD} - V_{SS}$ and $V_{DD} - V_{EE}$ supply-voltage ranges, independent of the logic state of the control signals.

Package Information

PART NUMBER	PACKAGE (1)	PACKAGE SIZE(2)
CD405xB	J (CDIP, 16)	19.50mm × 6.92mm
	N (PDIP, 16)	19.3mm × 9.4mm
	D (SOIC, 16)	9.9mm × mm
	NS (SOP, 16)	10.2mm × 7.8mm
	PW (TSSOP, 16)	5mm × 6.4mm

- (1) For all available packages, see the orderable addendum at the end of the data sheet.
- (2) The package size (length × width) is a nominal value and includes pins, where applicable.

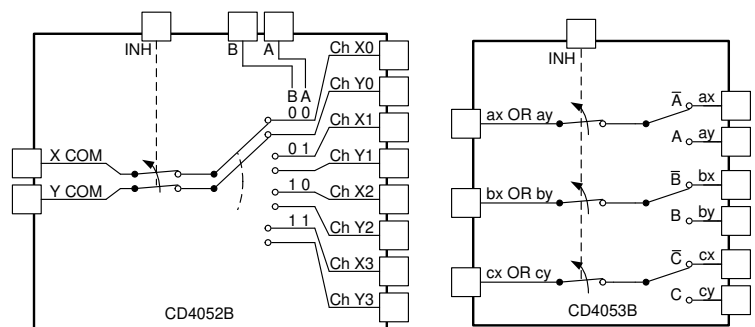
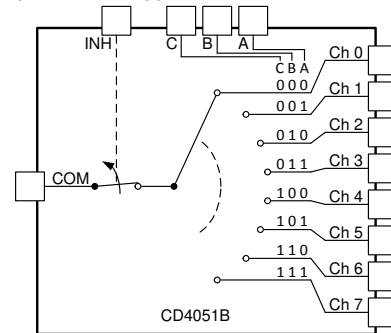

Functional Diagrams of CD4051B



Table of Contents

1 Features	1	7.4 Device Functional Modes.....	18
2 Applications	1	8 Application and Implementation	19
3 Description	1	8.1 Application Information.....	19
4 Pin Configuration and Functions	3	8.2 Typical Application.....	19
5 Specifications	5	8.3 Power Supply Recommendations.....	20
5.1 Absolute Maximum Ratings.....	5	8.4 Layout.....	21
5.2 ESD Ratings.....	5	9 Device and Documentation Support	22
5.3 Recommended Operating Conditions.....	5	9.1 Documentation Support.....	22
5.4 Thermal Information.....	5	9.2 Receiving Notification of Documentation Updates....	22
5.5 Electrical Characteristics.....	6	9.3 Support Resources.....	22
5.6 AC Performance Characteristics.....	10	9.4 Trademarks.....	22
5.7 Typical Characteristics.....	11	9.5 Electrostatic Discharge Caution.....	22
6 Parameter Measurement Information	11	9.6 Glossary.....	22
7 Detailed Description	15	10 Revision History	23
7.1 Overview.....	15	11 Mechanical, Packaging, and Orderable Information	23
7.2 Functional Block Diagrams.....	16		
7.3 Feature Description.....	17		

4 Pin Configuration and Functions

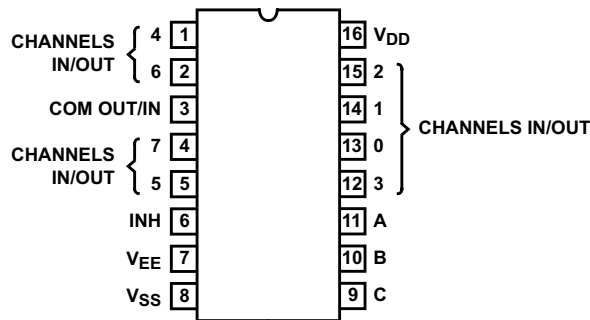

Figure 4-1. CD4051B E, M, NS, and PW Package, 16-Pin PDIP, CDIP, SOIC, SOP, and TSSOP (Top View)

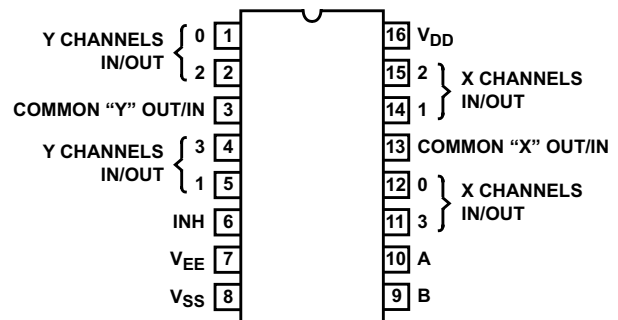

Figure 4-2. CD4052B E, M, NS, and PW Package, 16-Pin PDIP, CDIP, SOP, and TSSOP (Top View)

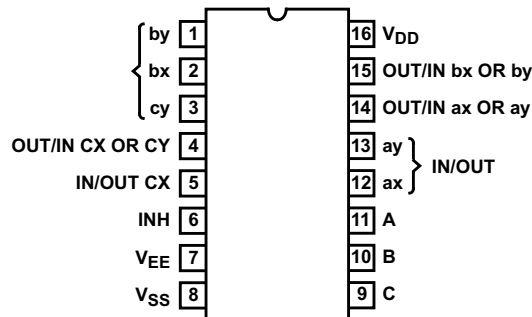

Figure 4-3. CD4053B E, M, NS, and PW Package, 16-Pin PDIP, CDIP, SOP, and TSSOP (Top View)

Table 4-1. Pin Functions CD4051B

PIN		TYPE ⁽¹⁾	DESCRIPTION
NO.	NAME		
1	CH 4 IN/OUT	I/O	Channel 4 in/out
2	CH 6 IN/OUT	I/O	Channel 6 in/out
3	COM OUT/IN	I/O	Common out/in
4	CH 7 IN/OUT	I/O	Channel 7 in/out
5	CH 5 IN/OUT	I/O	Channel 5 in/out
6	INH	I	Disables all channels. See Table 7-1 .
7	V _{EE}	—	Negative power input
8	V _{SS}	—	Ground
9	C	I	Channel select C. See Table 7-1 .
10	B	I	Channel select B. See Table 7-1 .
11	A	I	Channel select A. See Table 7-1 .
12	CH 3 IN/OUT	I/O	Channel 3 in/out
13	CH 0 IN/OUT	I/O	Channel 0 in/out
14	CH 1 IN/OUT	I/O	Channel 1 in/out
15	CH 2 IN/OUT	I/O	Channel 2 in/out
16	V _{DD}	—	Positive power input

(1) I = input, O = output

Table 4-2. Pin Functions CD4052B

PIN		TYPE ⁽¹⁾	DESCRIPTION
NO.	NAME		
1	Y CH 0 IN/OUT	I/O	Channel Y0 in/out
2	Y CH 2 IN/OUT	I/O	Channel Y2 in/out
3	Y COM OUT/IN	I/O	Y common out/in
4	Y CH 3 IN/OUT	I/O	Channel Y3 in/out
5	Y CH 1 IN/OUT	I/O	Channel Y1 in/out
6	INH	I	Disables all channels. See Table 7-1 .
7	V _{EE}	—	Negative power input
8	V _{SS}	—	Ground
9	B	I	Channel select B. See Table 7-1 .
10	A	I	Channel select A. See Table 7-1 .
11	X CH 3 IN/OUT	I/O	Channel X3 in/out
12	X CH 0 IN/OUT	I/O	Channel X0 in/out
13	X COM IN/OUT	I/O	X common out/in
14	X CH 1 IN/OUT	I/O	Channel in/out
15	X CH 2 IN/OUT	I/O	Channel in/out
16	V _{DD}	—	Positive power input

(1) I = input, O = output

Table 4-3. Pin Functions CD4053B

PIN		TYPE ⁽¹⁾	DESCRIPTION
NO.	NAME		
1	BY IN/OUT	I/O	B channel Y in/out
2	BX IN/OUT	I/O	B channel X in/out
3	CY IN/OUT	I/O	C channel Y in/out
4	CX OR CY OUT/IN	I/O	C common out/in
5	CX IN/OUT	I/O	C channel X in/out
6	INH	I	Disables all channels. See Table 7-1 .
7	V _{EE}	—	Negative power input
8	V _{SS}	—	Ground
9	C	I	Channel select C. See Table 7-1 .
10	B	I	Channel select B. See Table 7-1 .
11	A	I	Channel select A. See Table 7-1 .
12	AX IN/OUT	I/O	A channel X in/out
13	AY IN/OUT	I/O	A channel Y in/out
14	AX OR AY OUT/IN	I/O	A common out/in
15	BX OR BY OUT/IN	I/O	B common out/in
16	V _{DD}	—	Positive power input

(1) I = input, O = output

5 Specifications

5.1 Absolute Maximum Ratings

over operating free-air temperature range (unless otherwise noted)^{(1) (2)}

		MIN	MAX	UNIT	
	Supply Voltage	V+ to V-, Voltages Referenced to V _{SS} Terminal	-0.5	20	V
	DC Input Voltage		-0.5	V _{DD} +0.5	V
	DC Input Current	Any One Input	-10	10	mA
T _{JMAX1}	Maximum junction temperature, ceramic package			175	°C
T _{JMAX2}	Maximum junction temperature, plastic package			150	°C
T _{stg}	Storage temperature		-65	150	°C

- (1) Stresses beyond those listed under *Absolute Maximum Rating* may cause permanent damage to the device. These are stress ratings only, which do not imply functional operation of the device at these or any other conditions beyond those indicated under *Recommended Operating Condition*. Exposure to absolute-maximum-rated conditions for extended periods may affect device reliability.
- (2) All voltages are with respect to ground, unless otherwise specified.

5.2 ESD Ratings

		VALUE	UNIT	
V _(ESD)	Electrostatic discharge	Human body model (HBM), per ANSI/ESDA/ JEDEC JS-001, all pins ⁽¹⁾	±3000	V
		Charged device model (CDM), per JEDEC specification JESD22-C101, all pins ⁽²⁾	±2000	

- (1) JEDEC document JEP155 states that 500V HBM allows safe manufacturing with a standard ESD control process.
- (2) JEDEC document JEP157 states that 250V CDM allows safe manufacturing with a standard ESD control process.

5.3 Recommended Operating Conditions

over operating free-air temperature range (unless otherwise noted)

		MIN	NOM	MAX	UNIT
Temperature Range		-55		125	°C

5.4 Thermal Information

THERMAL METRIC ⁽¹⁾		CD405x				UNIT
		E (PDIP)	M (SOIC)	NS (SOP)	PW (TSSOP)	
		16 PINS	16 PINS	16 PINS	16 PINS	
R _{θJA}	Junction-to-ambient thermal resistance	67	73	64	116.5	°C/W

- (1) For more information about traditional and new thermal metrics, see the [Semiconductor and IC Package Thermal Metrics](#) application report.

5.5 Electrical Characteristics

Over operating free-air temperature range, $V_{SUPPLY} = \pm 5V$, and $R_L = 100\Omega$, (unless otherwise noted)⁽¹⁾

PARAMETER	TEST CONDITIONS				MIN	TYP	MAX	UNIT	
SIGNAL INPUTS (V_{IS}) AND OUTPUTS (V_{OS})									
	V_{IS} (V)	V_{EE} (V)	V_{SS} (V)	V_{DD} (V)	TEMP				
Quiescent Device Current, I_{DD} Max		0V	0V	5V	-55°C		60	μA	
					-40°C		60		
					25°C	17	60		
					85°C		150		
					125°C		150		
		0V	0V	10V		-55°C			60
						-40°C			60
						25°C	18		60
						85°C			300
						125°C			300
		0V	0V	15V		-55°C			60
						-40°C			60
						25°C	18		60
						85°C			600
						125°C			600
		0V	0V	20V		-55°C			100
						-40°C			100
						25°C	18		100
						85°C			3000
						125°C			3000
Drain to Source ON Resistance r_{ON} Max $0 \leq V_{IS} \leq V_{DD}$		0V	0V	5V	-55°C		800	Ω	
					-40°C		850		
					25°C	470	1050		
					85°C		1200		
					125°C		1300		
		0V	0V	10V		-55°C			310
						-40°C			300
						25°C	180		400
						85°C			520
						125°C			550
		0V	0	15V		-55°C			200
						-40°C			210
						25°C	125		240
						85°C			300
						125°C			300
Change in ON Resistance (Between Any Two Channels), ΔR_{ON}		0V	0V	5V	25°C		15	Ω	
		0V	0V	10V		10			
		0V	0V	15V		5			

5.5 Electrical Characteristics (continued)

Over operating free-air temperature range, $V_{SUPPLY} = \pm 5V$, and $R_L = 100\Omega$, (unless otherwise noted)⁽¹⁾

PARAMETER		TEST CONDITIONS				MIN	TYP	MAX	UNIT
OFF Channel Leakage Current: Any Channel OFF (Max) or ALL Channels OFF (COMMON OUT/IN) (Max)		0V	0V	18V	-55°C		± 100	nA	
					-40°C		± 100		
					25°C	± 0.3	± 100 (2)		
					85°C		± 1000 (2)		
					125°C		± 1000 (2)		
ON Channel Leakage Current: Any Channel ON (Max) or ALL Channels ON (COMMON OUT/IN) (Max)		5 or 0	-5V	0V	10.5V	85°C	± 300	nA	
		5	0V	0V	18V	85°C	± 300		
Capacitance	Input, C_{IS}	0V	0V	10V	25°C	5		pF	
	Output, C_{OS}					CD4051	30		
	Output, C_{OS}					CD4052	18		
	Output, C_{OS}					CD4053	9		
	Feed through, C_{IOS}						0.2		
Prop Delay		V_{DD}	$R_L = 200k\Omega$		5V	25°C	30	60	ns
			$C_L = 50pF$		10V		15	30	
			$t_r, t_f = 20ns$		15V		10	20	

5.5 Electrical Characteristics (continued)

Over operating free-air temperature range, $V_{SUPPLY} = \pm 5V$, and $R_L = 100\Omega$, (unless otherwise noted)⁽¹⁾

PARAMETER		TEST CONDITIONS			MIN	TYP	MAX	UNIT
CONTROL (ADDRESS OR INHIBIT), V_C								
Input Low Voltage, V_{IL} , Max		5V	–55°C		0.8		V	
			–40°C		0.8			
			25°C		0.8			
			85°C		0.8			
			125°C		0.8			
		10V	–55°C		0.8			
			–40°C		0.8			
			25°C		0.8			
			85°C		0.8			
			125°C		0.8			
		15V	–55°C		0.8			
			–40°C		0.8			
			25°C		0.8			
			85°C		0.8			
			125°C		0.8			
Input High Voltage, V_{IH} , Min		5V	–55°C		3.5			
			–40°C		3.5			
			25°C		3.5			
			85°C		3.5			
			125°C		3.5			
		10V	–55°C		7			
			–40°C		7			
			25°C		7			
			85°C		7			
			125°C		7			
		15V	–55°C		11			
			–40°C		11			
			25°C		11			
			85°C		11			
			125°C		11			
Input current, I_{IN} (Max)		$V_{IN} = 0, 18$	18V	–55°C		±1		
				–40°C		±1		
				25°C		±0.6 ±1		
				85°C		±1		
				125°C		±1		
Propagation Delay Time	Address-to-Signal OUT (Channels ON or OFF) (See Figure 10, Figure 11, and Figure 15)	$t_r, t_f = 20ns,$ $C_L = 50pF,$ $R_L = 10k\Omega$	0V	0V	5V	450	720	ns
			0V	0V	10V	160	320	
			0V	0V	15V	120	240	
			–5V	0V	5V	225	450	
Propagation Delay Time	Inhibit-to-Signal OUT (Channel Turning ON) (See Figure 11)	$t_r, t_f = 20ns,$ $C_L = 50pF,$ $R_L = 1k\Omega$	0V	0V	5V	400	720	ns
			0V	0V	10V	160	320	
			0V	0V	15V	120	240	
			–10V	0V	5V	200	400	

5.5 Electrical Characteristics (continued)

Over operating free-air temperature range, $V_{\text{SUPPLY}} = \pm 5\text{V}$, and $R_L = 100\Omega$, (unless otherwise noted)⁽¹⁾

PARAMETER		TEST CONDITIONS				MIN	TYP	MAX	UNIT
Propa- gation Delay Time	Inhibit-to-Signal OUT (Channel Turning OFF) (See Figure 17)	$t_r, t_f = 20\text{ns}$, $C_L = 50\text{pF}$, $R_L = 10\text{k}\Omega$	0V	0V	5V		200	450	ns
			0V	0V	10V		90	210	
			0V	0V	15V		70	160	
			-10V	0V	5V		130	300	
Input Capacitance, C_{IN} (Any Address or Inhibit Input)			-5V	0V	5V	25°C	5	7.5	pF

- (1) Peak-to-Peak voltage symmetrical about $(V_{\text{DD}} - V_{\text{EE}}) / 2$.
 (2) Determined by minimum feasible leakage measurement for automatic testing.

5.6 AC Performance Characteristics

 $V_{DD} = +15V, V_{SS} = V_{EE} = 0V, T_A = 25^\circ C$ (unless otherwise noted)

PARAMETER	TEST CONDITIONS			TYP	UNIT			
	V_{IS} (V)	V_{DD} (V)	R_L (k Ω)					
Cutoff (–3dB) Frequency Channel ON (Sine Wave Input)	5 ⁽¹⁾	10	1	V_{OS} at Common OUT/IN	CD4053	30	MHz	
		10	1		CD4052	25		
		10	1		CD4051	20		
	$V_{EE} = V_{SS}, 20\text{Log}(V_{OS}/V_{IS}) = -3\text{dB}$			V_{OS} at Any Channel		60		
Total Harmonic Distortion, THD	2 ⁽¹⁾	5	10	$V_{EE} = V_{SS}, f_{IS} = 1\text{kHz Sine Wave}$		0.3%	%	
	3 ⁽¹⁾	10	10		0.2%			
	5 ⁽¹⁾	15	10		0.12%			
–40dB Feedthrough Frequency (All Channels OFF)	5 ⁽¹⁾	10	1	V_{OS} at Common OUT/IN	CD4053	8	MHz	
					CD4052	10		
					CD4051	12		
	$V_{EE} = V_{SS}, 20\text{Log}(V_{OS}/V_{IS}) = -40\text{dB}$			V_{OS} at Any Channel		8		
–40dB Signal Crosstalk Frequency	5 ⁽¹⁾	10	1	Between Sections, CD4052 Only	Measured on Common	6	MHz	
					Measured on Any Channel	10		
					Between Any Two Sections, CD4053 Only	In Pin 2, Out Pin 14		2.5
						In Pin 15, Out Pin 14		6
Address-or-Inhibit-to- Signal Crosstalk	10		10 ⁽²⁾			65	mV _{PEAK}	
	$V_{EE} = 0, V_{SS} = 0, t_r, t_f = 20\text{ns}, \text{mVPEAK}$ $V_{CC} = V_{DD} - V_{SS}$ (Square Wave)					65	mV _{PEAK}	

(1) Peak-to-Peak voltage symmetrical about $(V_{DD} - V_{EE}) / 2$.

(2) Both ends of channel.

5.7 Typical Characteristics

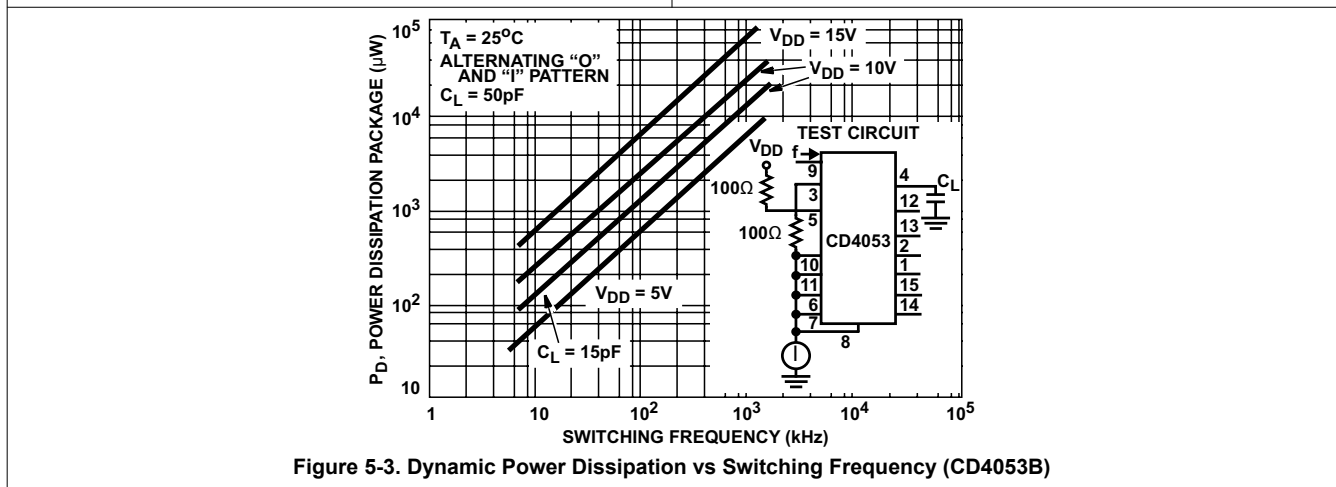
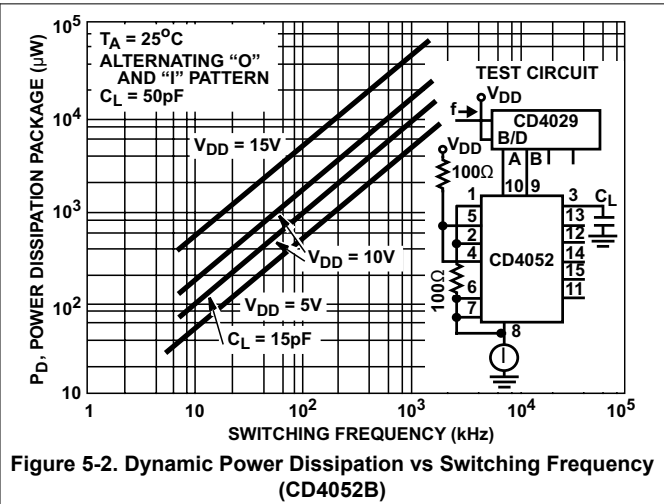
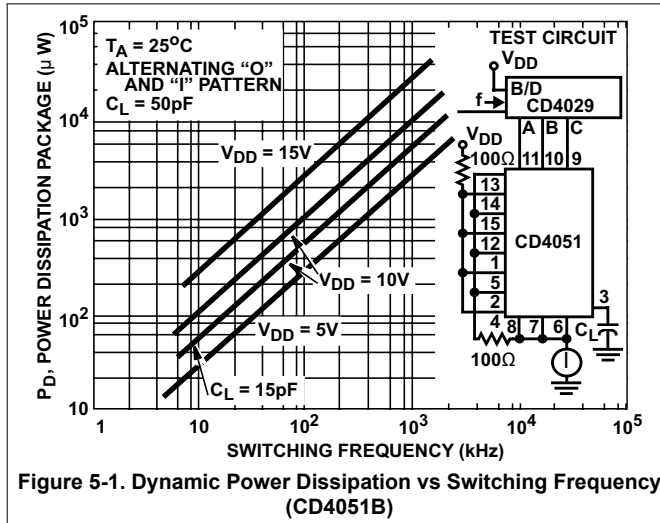

6 Parameter Measurement Information

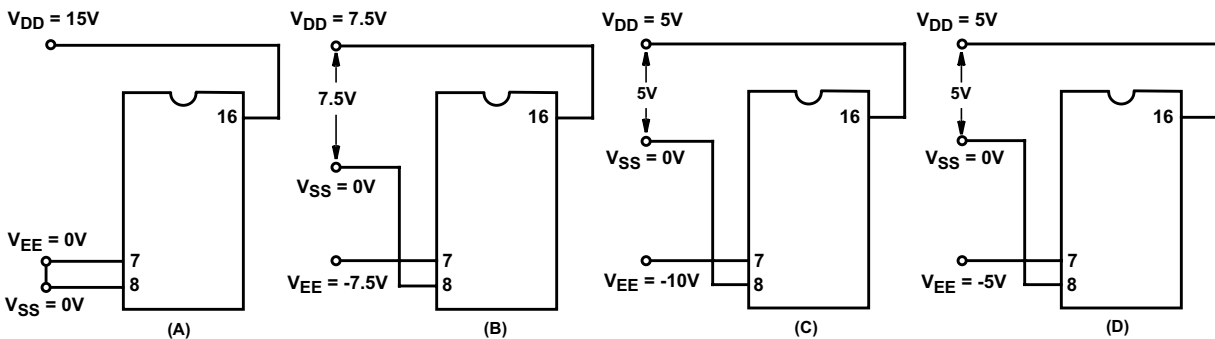

Figure 6-1. Typical Bias Voltages

Note

The ADDRESS (digital-control inputs) and INHIBIT logic levels are: 0 = V_{SS} and 1 = V_{DD} . The analog signal (through the TG) may swing from V_{EE} to V_{DD} .

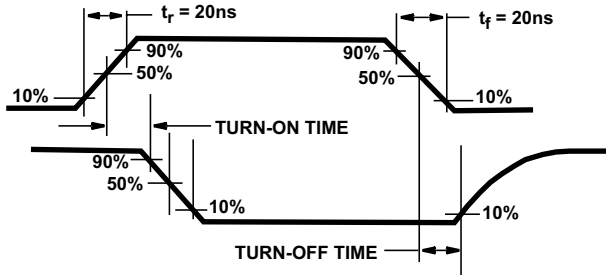

Figure 6-2. Waveforms, Channel Being Turned ON ($R_L = 1k\Omega$)

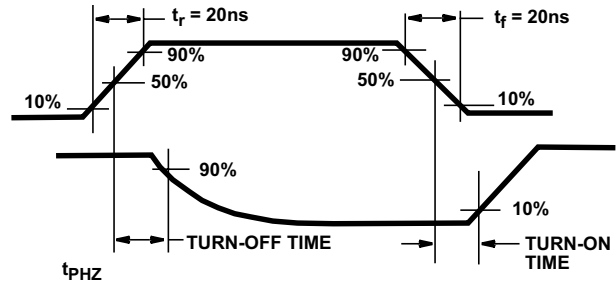

Figure 6-3. Waveforms, Channel Being Turned OFF ($R_L = 1k\Omega$)

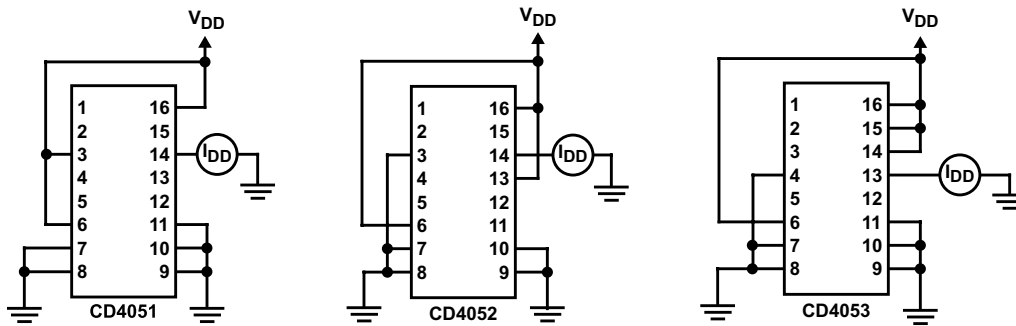
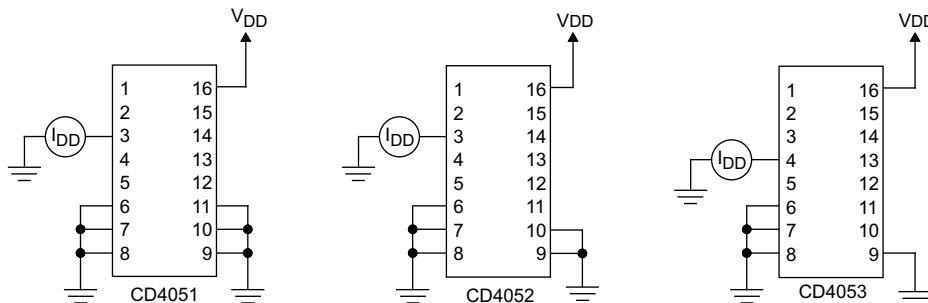

Figure 6-4. OFF Channel Leakage Current – Any Channel OFF



Copyright © 2017, Texas Instruments Incorporated

Figure 6-5. On Channel Leakage Current – Any Channel On

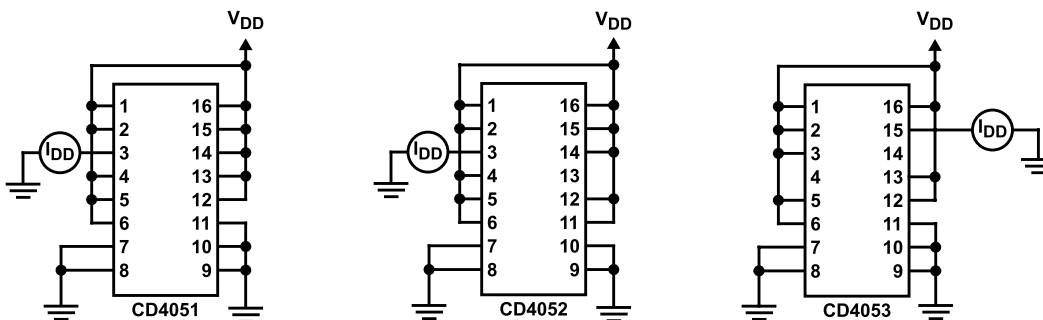

Figure 6-6. OFF Channel Leakage Current – All Channels OFF

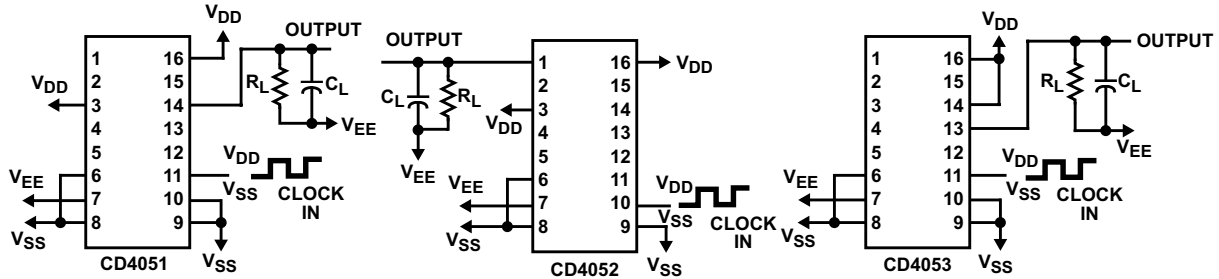

Figure 6-7. Propagation Delay – Address Input to Signal Output

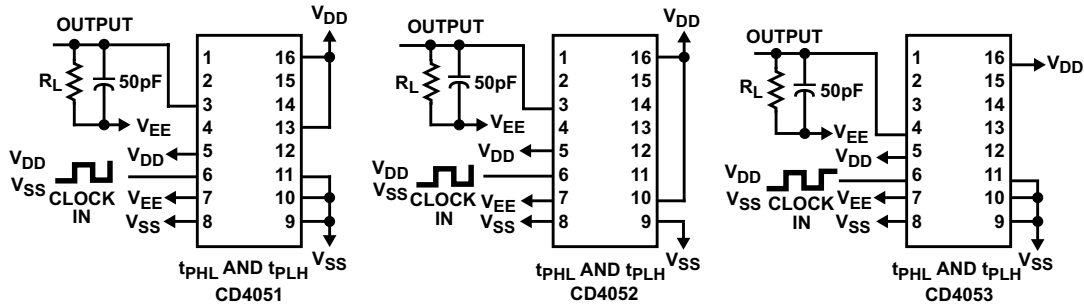
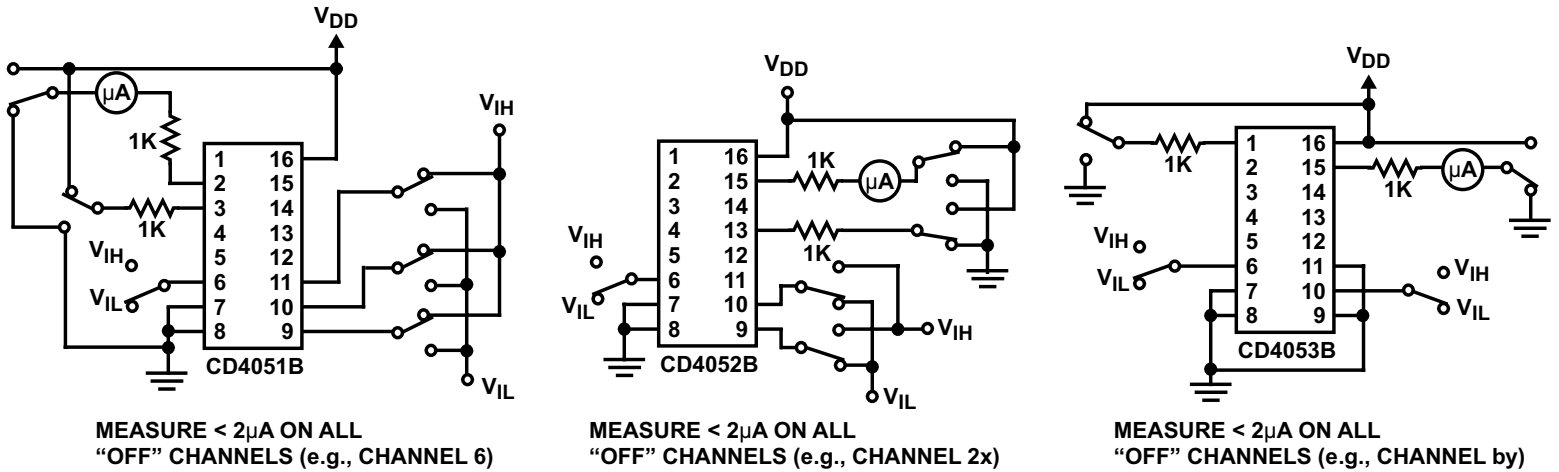

Figure 6-8. Propagation Delay – Inhibit Input to Signal Output



MEASURE < 2μA ON ALL
“OFF” CHANNELS (e.g., CHANNEL 6)

MEASURE < 2μA ON ALL
“OFF” CHANNELS (e.g., CHANNEL 2x)

MEASURE < 2μA ON ALL
“OFF” CHANNELS (e.g., CHANNEL by)

Figure 6-9. Input Voltage Test Circuits (Noise Immunity)

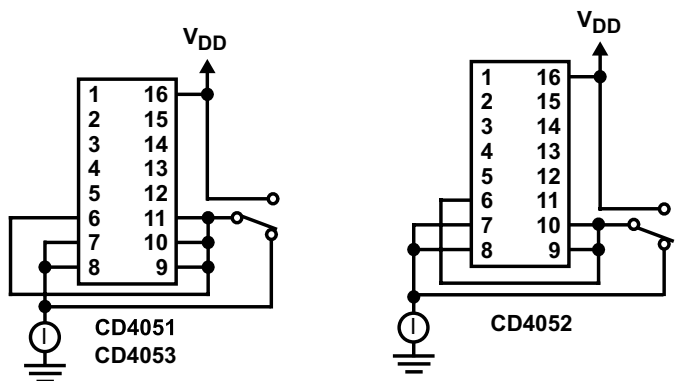

Figure 6-10. Quiescent Device Current

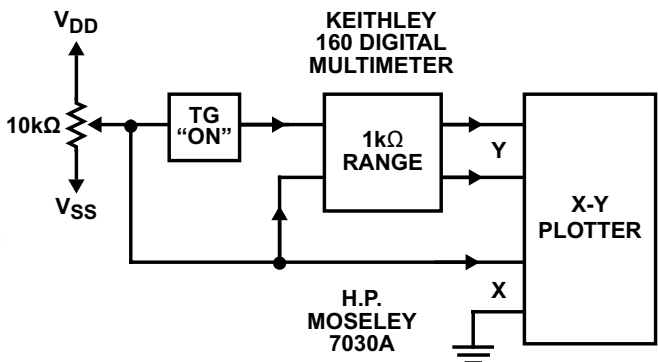

Figure 6-11. Channel ON Resistance Measurement Circuit

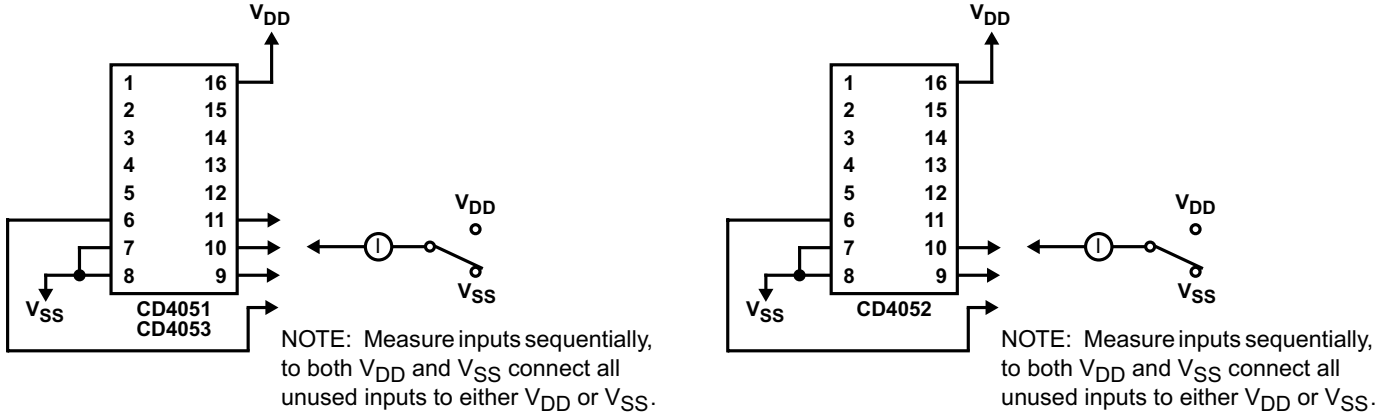

Figure 6-12. Input Current

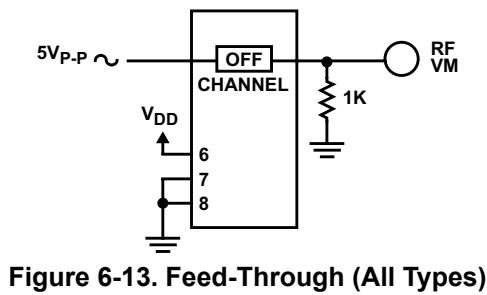

Figure 6-13. Feed-Through (All Types)

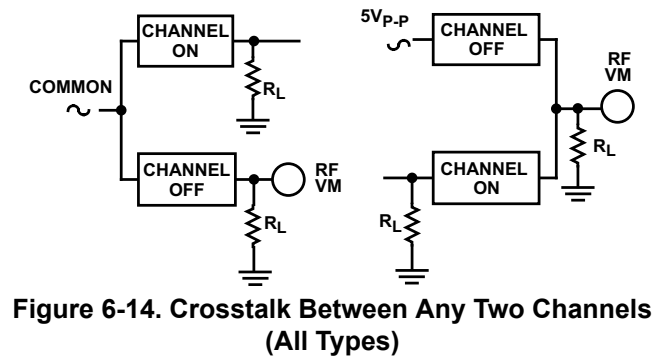
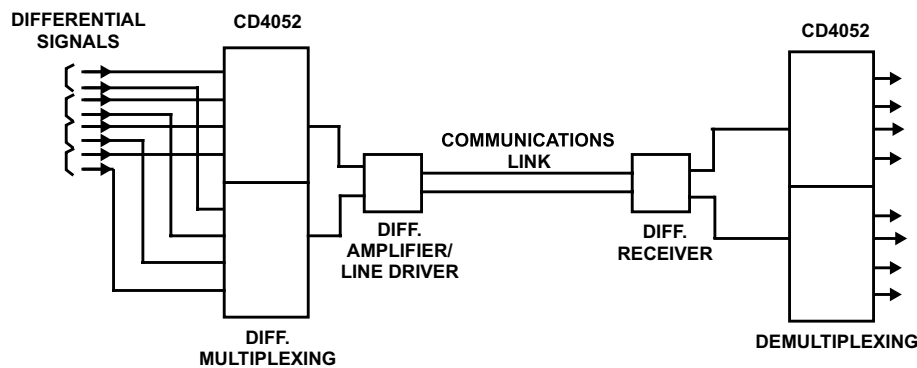

Figure 6-14. Crosstalk Between Any Two Channels (All Types)



Figure 6-15. Crosstalk Between Duals or Triplets (CD4052B, CD4053B)



Special Considerations: In applications where separate power sources are used to drive V_{DD} and the signal inputs, the V_{DD} current capability should exceed V_{DD}/R_L (R_L = effective external load). This provision avoids permanent current flow or clamp action on the V_{DD} supply when power is applied or removed from the CD4051B, CD4052B or CD4053B.

Figure 6-16. Typical Time-Division Application of the CD4052B

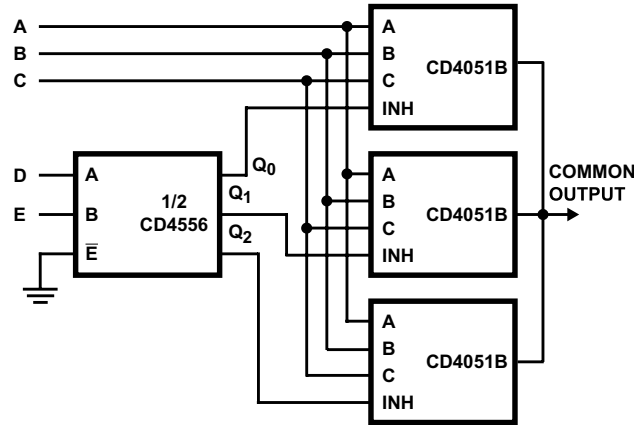

Figure 6-17. 24-to-1MUX Addressing

7 Detailed Description

7.1 Overview

The CD4051B device is a single 8-channel multiplexer having three binary control inputs, A, B, and C, and an inhibit input. The three binary signals select 1 of 8 channels to be turned on, and connect one of the 8 inputs to the output.

The CD4052B device is a differential 4-channel multiplexer having two binary control inputs, A and B, and an inhibit input. The two binary input signals select 1 of 4 pairs of channels to be turned on and connect the analog inputs to the outputs.

The device is a triple 2-channel multiplexer having three separate digital control inputs, A, B, and C, and an inhibit input. Each control input selects one of a pair of channels which are connected in a single-pole, double-throw configuration.

When these devices are used as demultiplexers, the CHANNEL IN/OUT terminals are the outputs and the COMMON OUT/IN terminals are the inputs.

7.2 Functional Block Diagrams

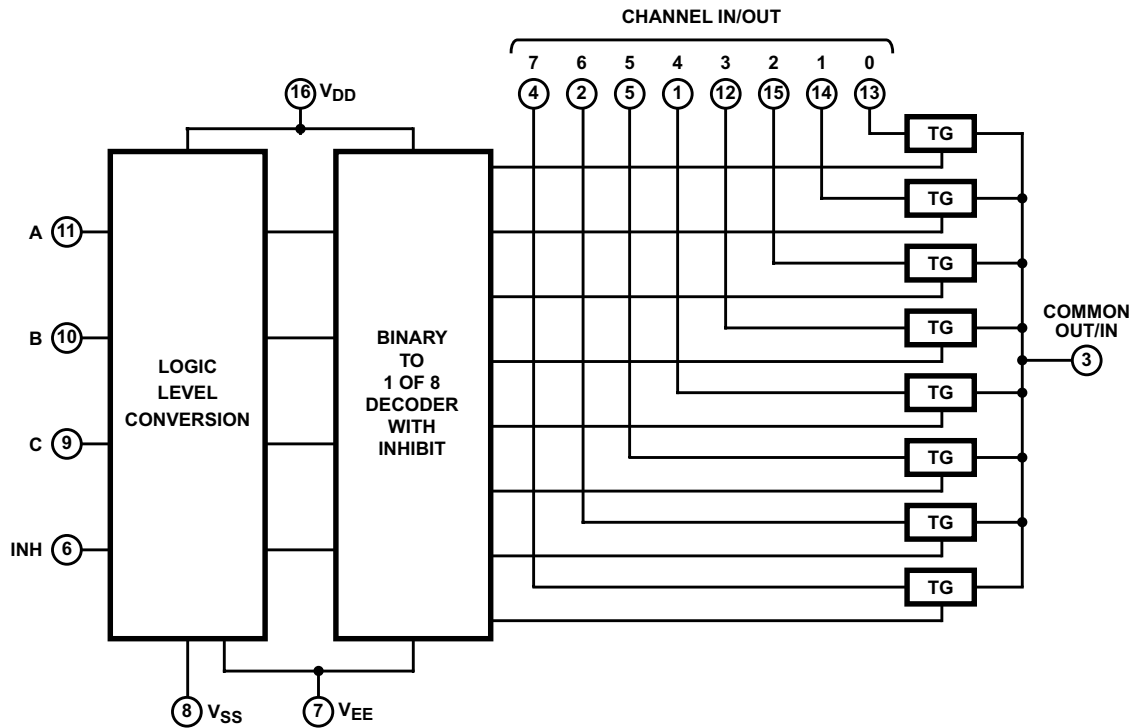

All inputs are protected by standard CMOS protection network.

Figure 7-1. Functional Block Diagram, CD4051B

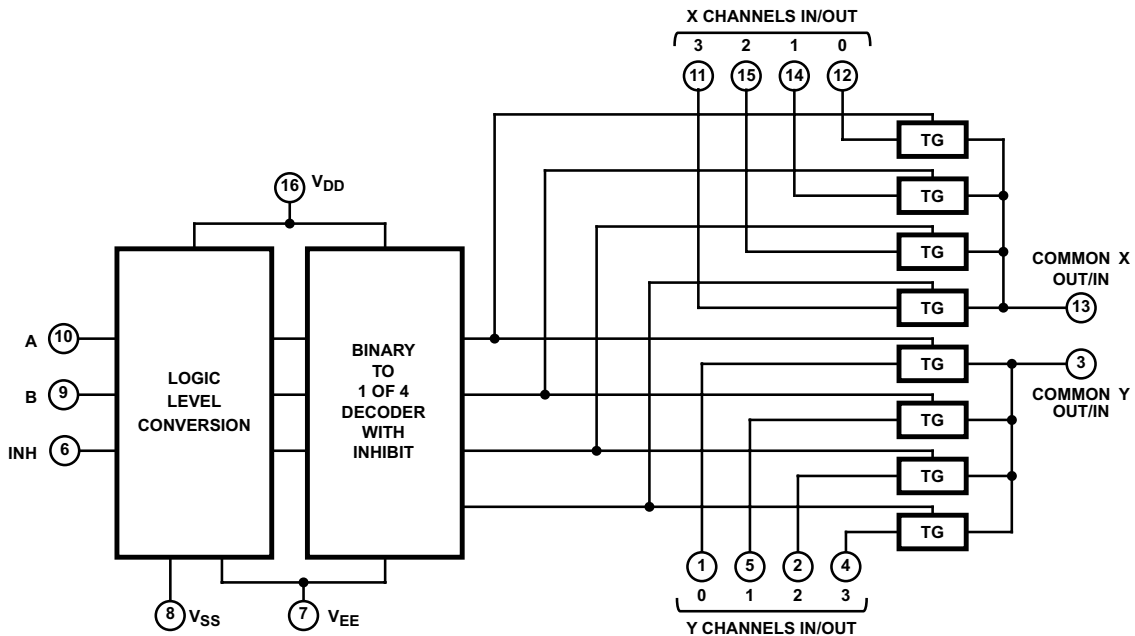

All inputs are protected by standard CMOS protection network.

Figure 7-2. Functional Block Diagram, CD4052B

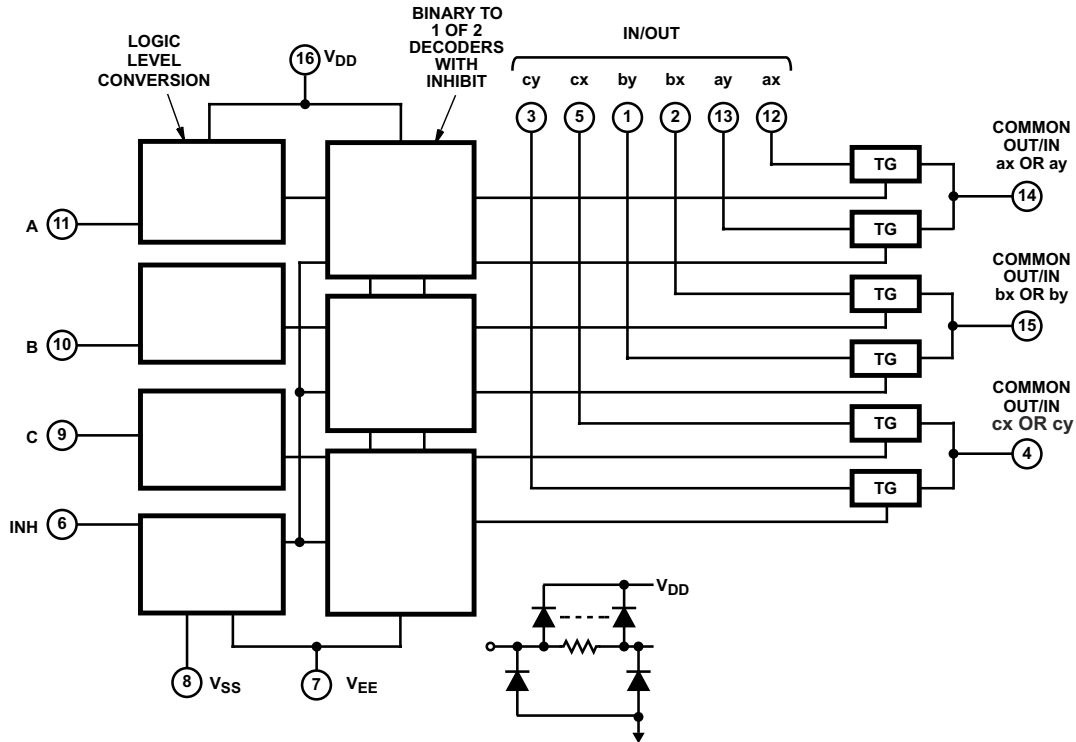

All inputs are protected by standard CMOS protection network.

Figure 7-3. Functional Block Diagram, CD4053B

7.3 Feature Description

The CD405xB line of multiplexers and demultiplexers can accept a wide range of digital and analog signal levels. Digital signals range from 3V to 20V, and analog signals are accepted at levels $\leq 20V$. The devices have low ON resistance, typically 125Ω over $15V_{P-P}$ signal input range for $V_{DD} - V_{EE} = 18V$. This feature allows for very little signal loss through the switch.

The CD405xB devices also have high OFF resistance, which keeps from the devices from wasting power when the switch is in the OFF position, with typical channel leakage of $\pm 100pA$ at $V_{DD} - V_{EE} = 18V$.

Binary address decoding on the chip makes channel selection simple. When channels are changed, a break-before-make system eliminates channel overlap.

7.4 Device Functional Modes

Table 7-1. Truth Table ⁽¹⁾

INPUT STATES				ON CHANNEL(S)
INHIBIT	C	B	A	
CD4051B				
0	0	0	0	0
0	0	0	1	1
0	0	1	0	2
0	0	1	1	3
0	1	0	0	4
0	1	0	1	5
0	1	1	0	6
0	1	1	1	7
1	X	X	X	None
CD4052B				
0		0	0	0x, 0y
0		0	1	1x, 1y
0		1	0	2x, 2y
0		1	1	3x, 3y
1		X	X	None
CD4053B				
0	X	X	0	ax
0	X	X	1	ay
0	X	0	X	bx
0	X	1	X	by
0	0	X	X	cx
0	1	X	X	cy
1	X	X	X	None

(1) X = Do not care

8 Application and Implementation

Note

Information in the following applications sections is not part of the TI component specification, and TI does not warrant its accuracy or completeness. TI's customers are responsible for determining suitability of components for their purposes, as well as validating and testing their design implementation to confirm system functionality.

8.1 Application Information

The CD405xB multiplexers and demultiplexers can be used for a wide variety of applications.

8.2 Typical Application

One application of the CD4051B is to use it in conjunction with a microcontroller to poll a keypad. [Figure 8-1](#) shows the basic schematic for such a polling system. The microcontroller uses the channel select pins to cycle through the different channels while reading the input to see if a user is pressing any of the keys. This application is a very robust setup, allowing for multiple simultaneous key-presses with very little power consumption. This setup also uses very few pins on the microcontroller. The down side of polling is that the microcontroller must continually scan the keys for a press and can do little else during this process.

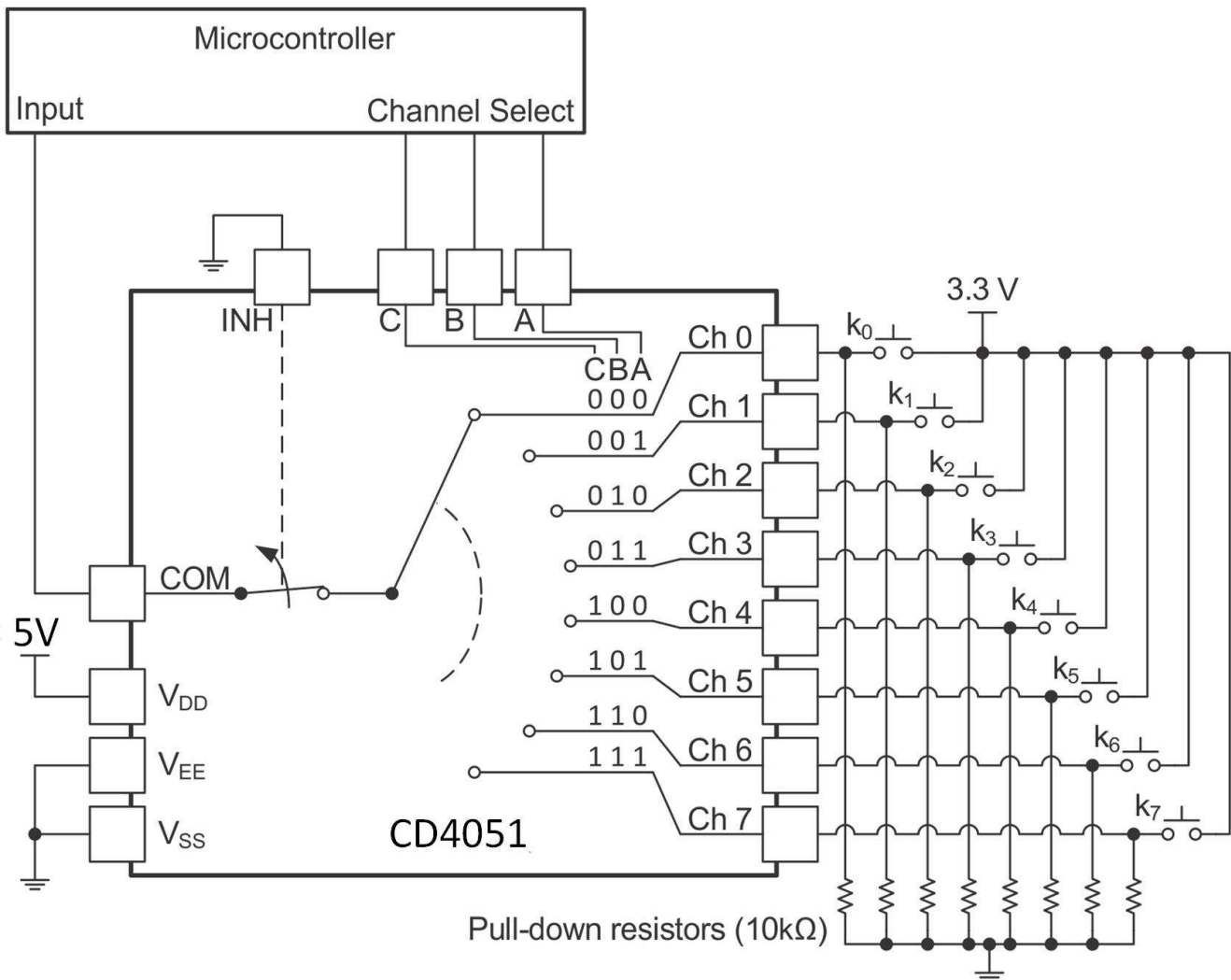

Figure 8-1. The CD4051B Being Used to Help Read Button Presses on a Keypad

8.2.1 Design Requirements

These devices use CMOS technology and have balanced output drive. Take care to avoid bus contention because it can drive currents that would exceed maximum limits. The high drive will also create fast edges into light loads, so routing and load conditions should be considered to prevent ringing.

8.2.2 Detailed Design Procedure

1. Recommended Input Conditions:
 - For switch time specifications, see propagation delay times in [Electrical Characteristics](#).
 - Inputs should not be pushed more than 0.5V above V_{DD} or below V_{EE} .
 - For input voltage level specifications for control inputs, see V_{IH} and V_{IL} in [Electrical Characteristics](#).
2. Recommended Output Conditions:
 - Outputs should not be pulled above V_{DD} or below V_{EE} .
3. Input or output current consideration:
 - The CD405xB series of parts do not have internal current drive circuitry and thus cannot sink or source current. Any current will be passed through the device.

8.2.3 Application Curve

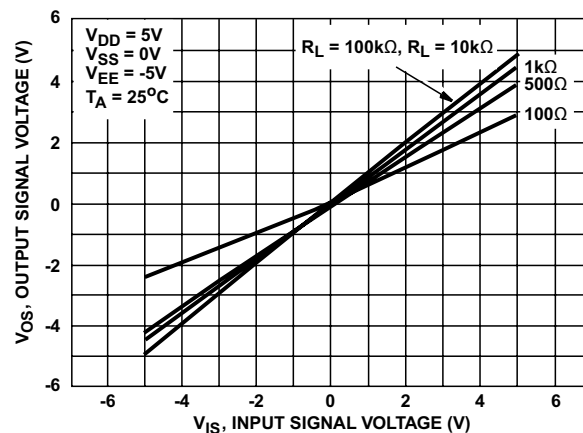

Figure 8-2. ON Characteristics for 1 of 8 Channels (CD4051B)

8.3 Power Supply Recommendations

The power supply can be any voltage between the minimum and maximum supply voltage rating located in the [Electrical Characteristics](#).

Each V_{CC} terminal should have a good bypass capacitor to prevent power disturbance. For devices with a single supply, a 0.1 μ F bypass capacitor is recommended. If there are multiple pins labeled V_{CC} , then a 0.01 μ F or 0.022 μ F capacitor is recommended for each V_{CC} because the V_{CC} pins will be tied together internally. For devices with dual supply pins operating at different voltages, for example V_{CC} and V_{DD} , a 0.1 μ F bypass capacitor is recommended for each supply pin. It is acceptable to parallel multiple bypass capacitors to reject different frequencies of noise. 0.1 μ F and 1 μ F capacitors are commonly used in parallel. The bypass capacitor should be installed as close to the power terminal as possible for best results.

8.4 Layout

8.4.1 Layout Guidelines

Reflections and matching are closely related to loop antenna theory, but different enough to warrant their own discussion. When a PCB trace turns a corner at a 90° angle, a reflection can occur. This reflection is primarily due to the change of width of the trace. At the apex of the turn, the trace width is increased to 1.414 times its width. This upsets the transmission line characteristics, especially the distributed capacitance and self-inductance of the trace — resulting in the reflection. It is a given that not all PCB traces can be straight, and so they will have to turn corners. [Figure 8-3](#) shows progressively better techniques of rounding corners. Only the last example maintains constant trace width and minimizes reflections.

8.4.2 Layout Example

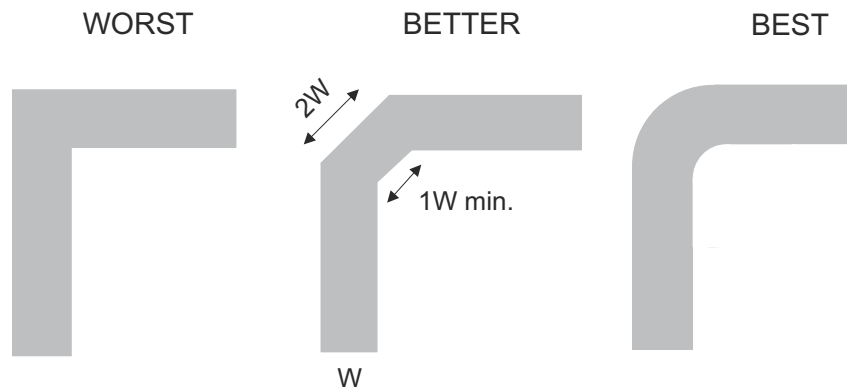

Figure 8-3. Trace Example

9 Device and Documentation Support

9.1 Documentation Support

9.1.1 Related Documentation

For related documentation, see the following:

- Texas Instruments, [Implications of Slow or Floating CMOS Inputs](#)

9.2 Receiving Notification of Documentation Updates

To receive notification of documentation updates, navigate to the device product folder on [ti.com](#). Click on *Notifications* to register and receive a weekly digest of any product information that has changed. For change details, review the revision history included in any revised document.

9.3 Support Resources

[TI E2E™ support forums](#) are an engineer's go-to source for fast, verified answers and design help — straight from the experts. Search existing answers or ask your own question to get the quick design help you need.

Linked content is provided "AS IS" by the respective contributors. They do not constitute TI specifications and do not necessarily reflect TI's views; see TI's [Terms of Use](#).

9.4 Trademarks

TI E2E™ is a trademark of Texas Instruments.
All trademarks are the property of their respective owners.

9.5 Electrostatic Discharge Caution



This integrated circuit can be damaged by ESD. Texas Instruments recommends that all integrated circuits be handled with appropriate precautions. Failure to observe proper handling and installation procedures can cause damage.

ESD damage can range from subtle performance degradation to complete device failure. Precision integrated circuits may be more susceptible to damage because very small parametric changes could cause the device not to meet its published specifications.

9.6 Glossary

[TI Glossary](#) This glossary lists and explains terms, acronyms, and definitions.

10 Revision History

NOTE: Page numbers for previous revisions may differ from page numbers in the current version.

Changes from Revision M (November 2024) to Revision N (February 2025)	Page
• Updated Section 1	1
• Removed Figure 5-4 and Figure 5-5.....	11
• Updated Section 7.1	15
• Updated Section 7.3	17
• Updated Figure 8-1 to 5V VDD.....	19

Changes from Revision L (September 2023) to Revision M (November 2024)	Page
• Updated the <i>Typical Characteristics</i> section.....	11
• Added Figure 5-4 and Figure 5-5.....	11

Changes from Revision K (March 2023) to Revision L (September 2023)	Page
• Changed the format of the <i>Package Information</i> table to include package lead size.....	1
• Changed the format of the <i>ESD Ratings, Electrical Characteristics, and AC Performance</i> to consolidate package specifications.....	5

11 Mechanical, Packaging, and Orderable Information

The following pages include mechanical, packaging, and orderable information. This information is the most current data available for the designated devices. This data is subject to change without notice and revision of this document. For browser-based versions of this data sheet, refer to the left-hand navigation.

PACKAGING INFORMATION

Orderable part number	Status (1)	Material type (2)	Package Pins	Package qty Carrier	RoHS (3)	Lead finish/ Ball material (4)	MSL rating/ Peak reflow (5)	Op temp (°C)	Part marking (6)
7901502EA	Active	Production	CDIP (J) 16	25 TUBE	No	SNPB	N/A for Pkg Type	-55 to 125	7901502EA CD4052BF3A
8101801EA	Active	Production	CDIP (J) 16	25 TUBE	No	SNPB	N/A for Pkg Type	-55 to 125	8101801EA CD4053BF3A
CD4051BE	Active	Production	PDIP (N) 16	25 TUBE	Yes	NIPDAU	N/A for Pkg Type	-55 to 125	CD4051BE
CD4051BE.A	Active	Production	PDIP (N) 16	25 TUBE	Yes	NIPDAU	N/A for Pkg Type	-55 to 125	CD4051BE
CD4051BEE4	Obsolete	Production	PDIP (N) 16	-	-	Call TI	Call TI	-55 to 125	CD4051BE
CD4051BF	Active	Production	CDIP (J) 16	25 TUBE	No	SNPB	N/A for Pkg Type	-55 to 125	CD4051BF
CD4051BF.A	Active	Production	CDIP (J) 16	25 TUBE	No	SNPB	N/A for Pkg Type	-55 to 125	CD4051BF
CD4051BF3A	Active	Production	CDIP (J) 16	25 TUBE	No	SNPB	N/A for Pkg Type	-55 to 125	CD4051BF3A
CD4051BF3A.A	Active	Production	CDIP (J) 16	25 TUBE	No	SNPB	N/A for Pkg Type	-55 to 125	CD4051BF3A
CD4051BM96	Active	Production	SOIC (D) 16	2500 LARGE T&R	Yes	NIPDAU	Level-1-260C-UNLIM	-55 to 125	CD4051BM
CD4051BM96.A	Active	Production	SOIC (D) 16	2500 LARGE T&R	Yes	NIPDAU	Level-1-260C-UNLIM	-55 to 125	CD4051BM
CD4051BM96G3	Obsolete	Production	SOIC (D) 16	-	-	Call TI	Call TI	-55 to 125	CD4051BM
CD4051BM96G4	Obsolete	Production	SOIC (D) 16	-	-	Call TI	Call TI	-55 to 125	CD4051BM
CD4051BMT	Obsolete	Production	SOIC (D) 16	-	-	Call TI	Call TI	-55 to 125	CD4051BM
CD4051BNSR	Active	Production	SOP (NS) 16	2000 LARGE T&R	Yes	NIPDAU	Level-1-260C-UNLIM	-55 to 125	CD4051B
CD4051BNSR.A	Active	Production	SOP (NS) 16	2000 LARGE T&R	Yes	NIPDAU	Level-1-260C-UNLIM	-55 to 125	CD4051B
CD4051BPW	Obsolete	Production	TSSOP (PW) 16	-	-	Call TI	Call TI	-55 to 125	CM051B
CD4051BPWR	Active	Production	TSSOP (PW) 16	2000 LARGE T&R	Yes	NIPDAU	Level-1-260C-UNLIM	-55 to 125	CM051B
CD4051BPWR.A	Active	Production	TSSOP (PW) 16	2000 LARGE T&R	Yes	NIPDAU	Level-1-260C-UNLIM	-55 to 125	CM051B
CD4051BPWRG4	Obsolete	Production	TSSOP (PW) 16	-	-	Call TI	Call TI	-55 to 125	CM051B
CD4052BE	Active	Production	PDIP (N) 16	25 TUBE	Yes	NIPDAU	N/A for Pkg Type	-55 to 125	CD4052BE
CD4052BE.A	Active	Production	PDIP (N) 16	25 TUBE	Yes	NIPDAU	N/A for Pkg Type	-55 to 125	CD4052BE
CD4052BF	Active	Production	CDIP (J) 16	25 TUBE	No	SNPB	N/A for Pkg Type	-55 to 125	CD4052BF
CD4052BF.A	Active	Production	CDIP (J) 16	25 TUBE	No	SNPB	N/A for Pkg Type	-55 to 125	CD4052BF
CD4052BF3A	Active	Production	CDIP (J) 16	25 TUBE	No	SNPB	N/A for Pkg Type	-55 to 125	7901502EA CD4052BF3A
CD4052BF3A.A	Active	Production	CDIP (J) 16	25 TUBE	No	SNPB	N/A for Pkg Type	-55 to 125	7901502EA CD4052BF3A

Orderable part number	Status (1)	Material type (2)	Package Pins	Package qty Carrier	RoHS (3)	Lead finish/ Ball material (4)	MSL rating/ Peak reflow (5)	Op temp (°C)	Part marking (6)
CD4052BM	Obsolete	Production	SOIC (D) 16	-	-	Call TI	Call TI	-55 to 125	CD4052BM
CD4052BM96	Active	Production	SOIC (D) 16	2500 LARGE T&R	Yes	NIPDAU	Level-1-260C-UNLIM	-55 to 125	CD4052BM
CD4052BM96.A	Active	Production	SOIC (D) 16	2500 LARGE T&R	Yes	NIPDAU	Level-1-260C-UNLIM	-55 to 125	CD4052BM
CD4052BM961G4	Active	Production	SOIC (D) 16	2500 LARGE T&R	Yes	NIPDAU	Level-1-260C-UNLIM	-55 to 125	CD4052BM
CD4052BM961G4.A	Active	Production	SOIC (D) 16	2500 LARGE T&R	Yes	NIPDAU	Level-1-260C-UNLIM	-55 to 125	CD4052BM
CD4052BM96G3	Obsolete	Production	SOIC (D) 16	-	-	Call TI	Call TI	-55 to 125	CD4052BM
CD4052BM96G4	Obsolete	Production	SOIC (D) 16	-	-	Call TI	Call TI	-55 to 125	CD4052BM
CD4052BMT	Obsolete	Production	SOIC (D) 16	-	-	Call TI	Call TI	-55 to 125	CD4052BM
CD4052BNSR	Active	Production	SOP (NS) 16	2000 LARGE T&R	Yes	NIPDAU	Level-1-260C-UNLIM	-55 to 125	CD4052B
CD4052BNSR.A	Active	Production	SOP (NS) 16	2000 LARGE T&R	Yes	NIPDAU	Level-1-260C-UNLIM	-55 to 125	CD4052B
CD4052BPW	Obsolete	Production	TSSOP (PW) 16	-	-	Call TI	Call TI	-55 to 125	CM052B
CD4052BPWR	Active	Production	TSSOP (PW) 16	2000 LARGE T&R	Yes	NIPDAU	Level-1-260C-UNLIM	-55 to 125	CM052B
CD4052BPWR.A	Active	Production	TSSOP (PW) 16	2000 LARGE T&R	Yes	NIPDAU	Level-1-260C-UNLIM	-55 to 125	CM052B
CD4052BPWRG3	Obsolete	Production	TSSOP (PW) 16	-	-	Call TI	Call TI	-55 to 125	CM052B
CD4052BPWRG4	Obsolete	Production	TSSOP (PW) 16	-	-	Call TI	Call TI	-55 to 125	CM052B
CD4053BE	Active	Production	PDIP (N) 16	25 TUBE	Yes	NIPDAU	N/A for Pkg Type	-55 to 125	CD4053BE
CD4053BE.A	Active	Production	PDIP (N) 16	25 TUBE	Yes	NIPDAU	N/A for Pkg Type	-55 to 125	CD4053BE
CD4053BEE4	Active	Production	PDIP (N) 16	25 TUBE	Yes	NIPDAU	N/A for Pkg Type	-55 to 125	CD4053BE
CD4053BF	Active	Production	CDIP (J) 16	25 TUBE	No	SNPB	N/A for Pkg Type	-55 to 125	CD4053BF
CD4053BF.A	Active	Production	CDIP (J) 16	25 TUBE	No	SNPB	N/A for Pkg Type	-55 to 125	CD4053BF
CD4053BF3A	Active	Production	CDIP (J) 16	25 TUBE	No	SNPB	N/A for Pkg Type	-55 to 125	8101801EA CD4053BF3A
CD4053BF3A.A	Active	Production	CDIP (J) 16	25 TUBE	No	SNPB	N/A for Pkg Type	-55 to 125	8101801EA CD4053BF3A
CD4053BM	Obsolete	Production	SOIC (D) 16	-	-	Call TI	Call TI	-55 to 125	CD4053M
CD4053BM96	Active	Production	SOIC (D) 16	2500 LARGE T&R	Yes	NIPDAU	Level-1-260C-UNLIM	-55 to 125	CD4053M
CD4053BM96.A	Active	Production	SOIC (D) 16	2500 LARGE T&R	Yes	NIPDAU	Level-1-260C-UNLIM	-55 to 125	CD4053M
CD4053BM96G3	Obsolete	Production	SOIC (D) 16	-	-	Call TI	Call TI	-55 to 125	CD4053M
CD4053BM96G4	Obsolete	Production	SOIC (D) 16	-	-	Call TI	Call TI	-55 to 125	CD4053M
CD4053BMT	Obsolete	Production	SOIC (D) 16	-	-	Call TI	Call TI	-55 to 125	CD4053M
CD4053BNSR	Active	Production	SOP (NS) 16	2000 LARGE T&R	Yes	NIPDAU	Level-1-260C-UNLIM	-55 to 125	CD4053B

Orderable part number	Status (1)	Material type (2)	Package Pins	Package qty Carrier	RoHS (3)	Lead finish/ Ball material (4)	MSL rating/ Peak reflow (5)	Op temp (°C)	Part marking (6)
CD4053BNSR.A	Active	Production	SOP (NS) 16	2000 LARGE T&R	Yes	NIPDAU	Level-1-260C-UNLIM	-55 to 125	CD4053B
CD4053BPW	Obsolete	Production	TSSOP (PW) 16	-	-	Call TI	Call TI	-55 to 125	CM053B
CD4053BPWR	Active	Production	TSSOP (PW) 16	2000 LARGE T&R	Yes	NIPDAU	Level-1-260C-UNLIM	-55 to 125	CM053B
CD4053BPWR.A	Active	Production	TSSOP (PW) 16	2000 LARGE T&R	Yes	NIPDAU	Level-1-260C-UNLIM	-55 to 125	CM053B
CD4053BPWRG3	Obsolete	Production	TSSOP (PW) 16	-	-	Call TI	Call TI	-55 to 125	CM053B
CD4053BPWRG4	Obsolete	Production	TSSOP (PW) 16	-	-	Call TI	Call TI	-55 to 125	CM053B

(1) **Status:** For more details on status, see our [product life cycle](#).

(2) **Material type:** When designated, preproduction parts are prototypes/experimental devices, and are not yet approved or released for full production. Testing and final process, including without limitation quality assurance, reliability performance testing, and/or process qualification, may not yet be complete, and this item is subject to further changes or possible discontinuation. If available for ordering, purchases will be subject to an additional waiver at checkout, and are intended for early internal evaluation purposes only. These items are sold without warranties of any kind.

(3) **RoHS values:** Yes, No, RoHS Exempt. See the [TI RoHS Statement](#) for additional information and value definition.

(4) **Lead finish/Ball material:** Parts may have multiple material finish options. Finish options are separated by a vertical ruled line. Lead finish/Ball material values may wrap to two lines if the finish value exceeds the maximum column width.

(5) **MSL rating/Peak reflow:** The moisture sensitivity level ratings and peak solder (reflow) temperatures. In the event that a part has multiple moisture sensitivity ratings, only the lowest level per JEDEC standards is shown. Refer to the shipping label for the actual reflow temperature that will be used to mount the part to the printed circuit board.

(6) **Part marking:** There may be an additional marking, which relates to the logo, the lot trace code information, or the environmental category of the part.

Multiple part markings will be inside parentheses. Only one part marking contained in parentheses and separated by a "~" will appear on a part. If a line is indented then it is a continuation of the previous line and the two combined represent the entire part marking for that device.

Important Information and Disclaimer: The information provided on this page represents TI's knowledge and belief as of the date that it is provided. TI bases its knowledge and belief on information provided by third parties, and makes no representation or warranty as to the accuracy of such information. Efforts are underway to better integrate information from third parties. TI has taken and continues to take reasonable steps to provide representative and accurate information but may not have conducted destructive testing or chemical analysis on incoming materials and chemicals. TI and TI suppliers consider certain information to be proprietary, and thus CAS numbers and other limited information may not be available for release.

In no event shall TI's liability arising out of such information exceed the total purchase price of the TI part(s) at issue in this document sold by TI to Customer on an annual basis.

OTHER QUALIFIED VERSIONS OF CD4051B, CD4051B-MIL, CD4052B, CD4052B-MIL, CD4053B, CD4053B-MIL :

- Catalog : [CD4051B](#), [CD4052B](#), [CD4053B](#)
- Automotive : [CD4051B-Q1](#), [CD4051B-Q1](#), [CD4053B-Q1](#), [CD4053B-Q1](#)
- Military : [CD4051B-MIL](#), [CD4052B-MIL](#), [CD4053B-MIL](#)

NOTE: Qualified Version Definitions:

- Catalog - TI's standard catalog product
- Automotive - Q100 devices qualified for high-reliability automotive applications targeting zero defects
- Military - QML certified for Military and Defense Applications

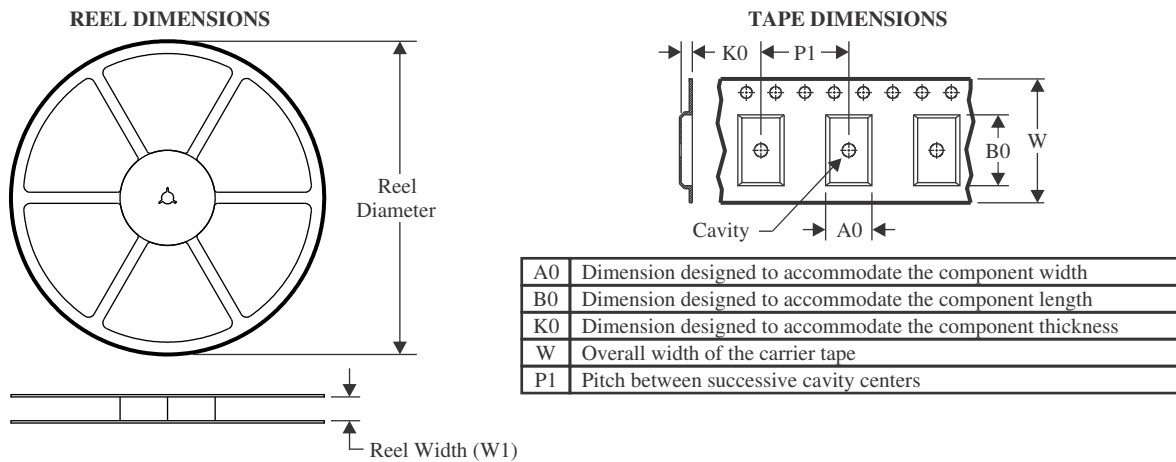
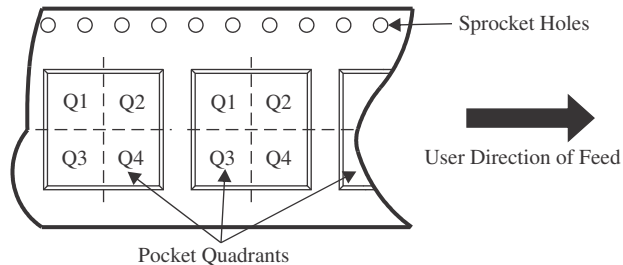
TAPE AND REEL INFORMATION

QUADRANT ASSIGNMENTS FOR PIN 1 ORIENTATION IN TAPE

*All dimensions are nominal

Device	Package Type	Package Drawing	Pins	SPQ	Reel Diameter (mm)	Reel Width W1 (mm)	A0 (mm)	B0 (mm)	K0 (mm)	P1 (mm)	W (mm)	Pin1 Quadrant
CD4051BM96	SOIC	D	16	2500	330.0	16.4	6.5	10.3	2.1	8.0	16.0	Q1
CD4051BM96	SOIC	D	16	2500	330.0	16.4	6.5	10.3	2.1	8.0	16.0	Q1
CD4051BNSR	SOP	NS	16	2000	330.0	16.4	8.1	10.4	2.5	12.0	16.0	Q1
CD4051BPWR	TSSOP	PW	16	2000	330.0	12.4	6.9	5.6	1.6	8.0	12.0	Q1
CD4051BPWR	TSSOP	PW	16	2000	330.0	12.4	6.9	5.6	1.6	8.0	12.0	Q1
CD4052BM96	SOIC	D	16	2500	330.0	16.4	6.5	10.3	2.1	8.0	16.0	Q1
CD4052BM961G4	SOIC	D	16	2500	330.0	16.4	6.5	10.3	2.1	8.0	16.0	Q1
CD4052BNSR	SOP	NS	16	2000	330.0	16.4	8.1	10.4	2.5	12.0	16.0	Q1
CD4052BPWR	TSSOP	PW	16	2000	330.0	12.4	6.9	5.6	1.6	8.0	12.0	Q1
CD4052BPWR	TSSOP	PW	16	2000	330.0	12.4	6.9	5.6	1.6	8.0	12.0	Q1
CD4053BM96	SOIC	D	16	2500	330.0	16.4	6.5	10.3	2.1	8.0	16.0	Q1
CD4053BM96	SOIC	D	16	2500	330.0	16.4	6.5	10.3	2.1	8.0	16.0	Q1
CD4053BNSR	SOP	NS	16	2000	330.0	16.4	8.1	10.4	2.5	12.0	16.0	Q1
CD4053BPWR	TSSOP	PW	16	2000	330.0	12.4	6.9	5.6	1.6	8.0	12.0	Q1
CD4053BPWR	TSSOP	PW	16	2000	330.0	12.4	6.9	5.6	1.6	8.0	12.0	Q1

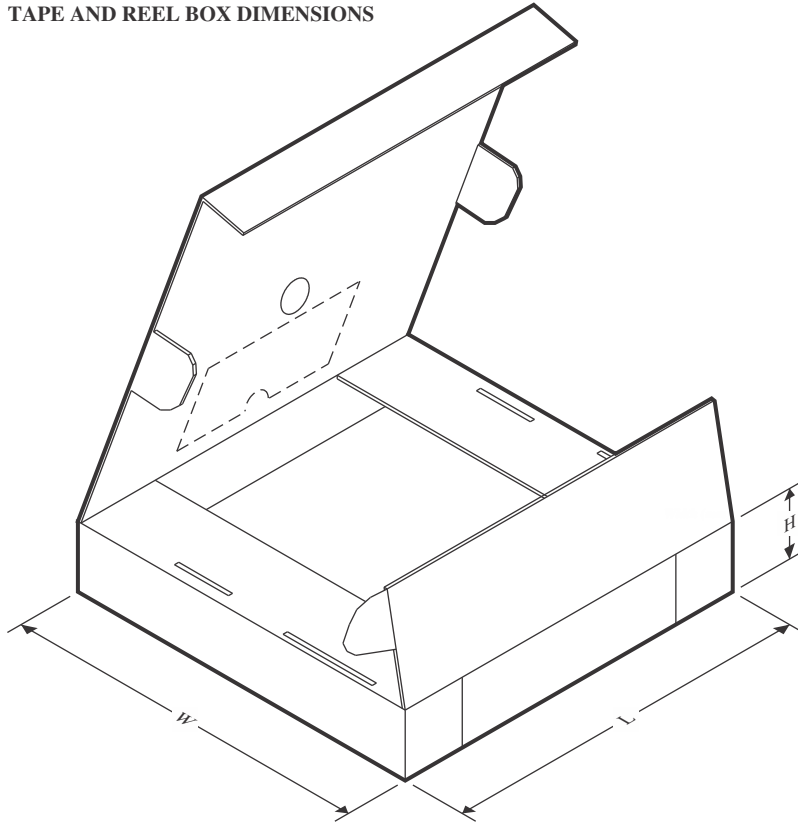
TAPE AND REEL BOX DIMENSIONS



*All dimensions are nominal

Device	Package Type	Package Drawing	Pins	SPQ	Length (mm)	Width (mm)	Height (mm)
CD4051BM96	SOIC	D	16	2500	353.0	353.0	32.0
CD4051BM96	SOIC	D	16	2500	340.5	336.1	32.0
CD4051BNSR	SOP	NS	16	2000	353.0	353.0	32.0
CD4051BPWR	TSSOP	PW	16	2000	367.0	367.0	35.0
CD4051BPWR	TSSOP	PW	16	2000	353.0	353.0	32.0
CD4052BM96	SOIC	D	16	2500	353.0	353.0	32.0
CD4052BM961G4	SOIC	D	16	2500	353.0	353.0	32.0
CD4052BNSR	SOP	NS	16	2000	353.0	353.0	32.0
CD4052BPWR	TSSOP	PW	16	2000	353.0	353.0	32.0
CD4052BPWR	TSSOP	PW	16	2000	367.0	367.0	35.0
CD4053BM96	SOIC	D	16	2500	353.0	353.0	32.0
CD4053BM96	SOIC	D	16	2500	353.0	353.0	32.0
CD4053BNSR	SOP	NS	16	2000	353.0	353.0	32.0
CD4053BPWR	TSSOP	PW	16	2000	353.0	353.0	32.0
CD4053BPWR	TSSOP	PW	16	2000	367.0	367.0	35.0

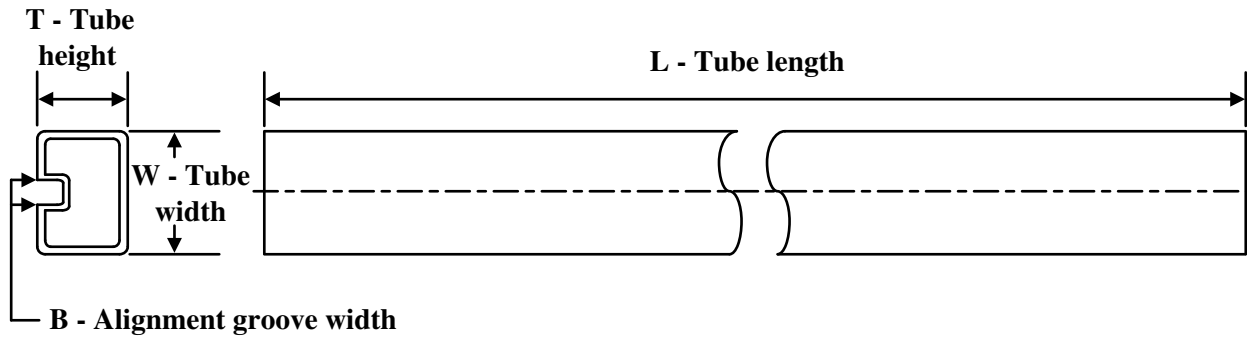
TUBE

*All dimensions are nominal

Device	Package Name	Package Type	Pins	SPQ	L (mm)	W (mm)	T (μm)	B (mm)
CD4051BE	N	PDIP	16	25	506	13.97	11230	4.32
CD4051BE.A	N	PDIP	16	25	506	13.97	11230	4.32
CD4052BE	N	PDIP	16	25	506	13.97	11230	4.32
CD4052BE.A	N	PDIP	16	25	506	13.97	11230	4.32
CD4052BEE4	N	PDIP	16	25	506	13.97	11230	4.32
CD4053BE	N	PDIP	16	25	506	13.97	11230	4.32
CD4053BE.A	N	PDIP	16	25	506	13.97	11230	4.32
CD4053BEE4	N	PDIP	16	25	506	13.97	11230	4.32

J (R-GDIP-T**)

14 LEADS SHOWN

CERAMIC DUAL IN-LINE PACKAGE

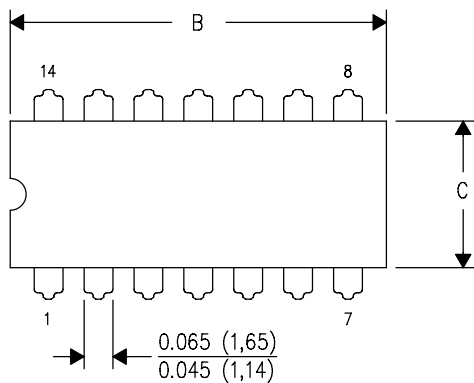

DIM \ PINS **	14	16	18	20
A	0.300 (7,62) BSC	0.300 (7,62) BSC	0.300 (7,62) BSC	0.300 (7,62) BSC
B MAX	0.785 (19,94)	.840 (21,34)	0.960 (24,38)	1.060 (26,92)
B MIN	—	—	—	—
C MAX	0.300 (7,62)	0.300 (7,62)	0.310 (7,87)	0.300 (7,62)
C MIN	0.245 (6,22)	0.245 (6,22)	0.220 (5,59)	0.245 (6,22)

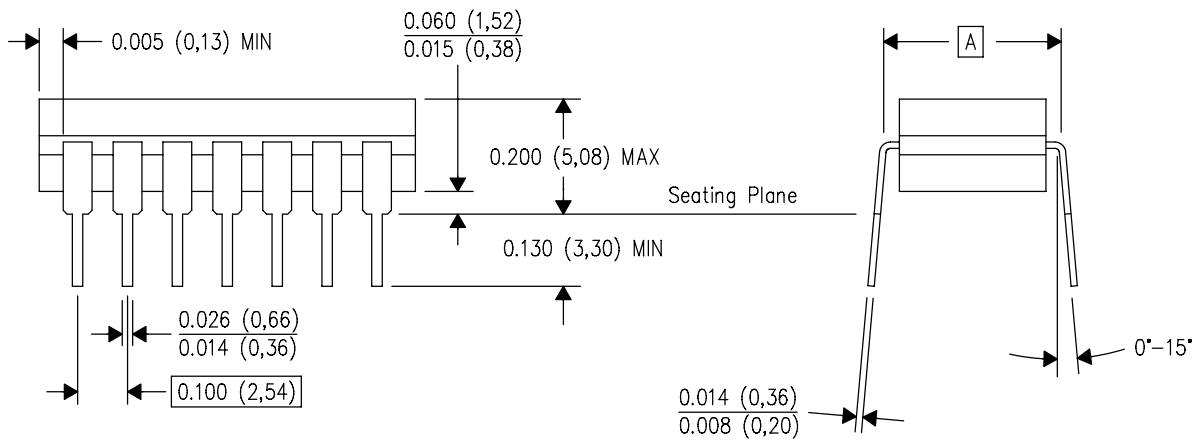

4040083/F 03/03

- NOTES:
- A. All linear dimensions are in inches (millimeters).
 - B. This drawing is subject to change without notice.
 - C. This package is hermetically sealed with a ceramic lid using glass frit.
 - D. Index point is provided on cap for terminal identification only on press ceramic glass frit seal only.
 - E. Falls within MIL STD 1835 GDIP1-T14, GDIP1-T16, GDIP1-T18 and GDIP1-T20.

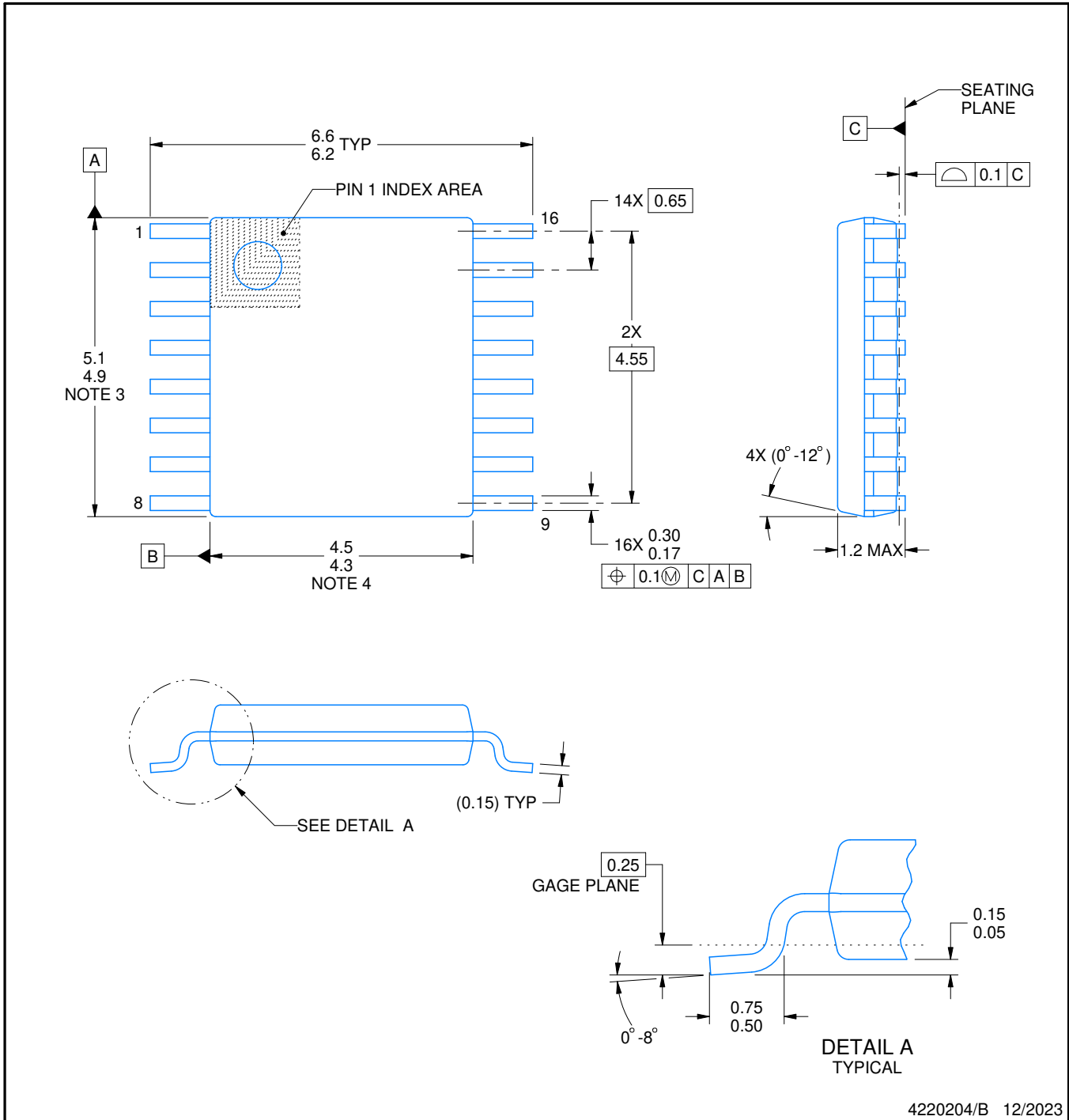

4220204/B 12/2023

NOTES:

1. All linear dimensions are in millimeters. Any dimensions in parenthesis are for reference only. Dimensioning and tolerancing per ASME Y14.5M.
2. This drawing is subject to change without notice.
3. This dimension does not include mold flash, protrusions, or gate burrs. Mold flash, protrusions, or gate burrs shall not exceed 0.15 mm per side.
4. This dimension does not include interlead flash. Interlead flash shall not exceed 0.25 mm per side.
5. Reference JEDEC registration MO-153.

EXAMPLE BOARD LAYOUT

PW0016A

TSSOP - 1.2 mm max height

SMALL OUTLINE PACKAGE

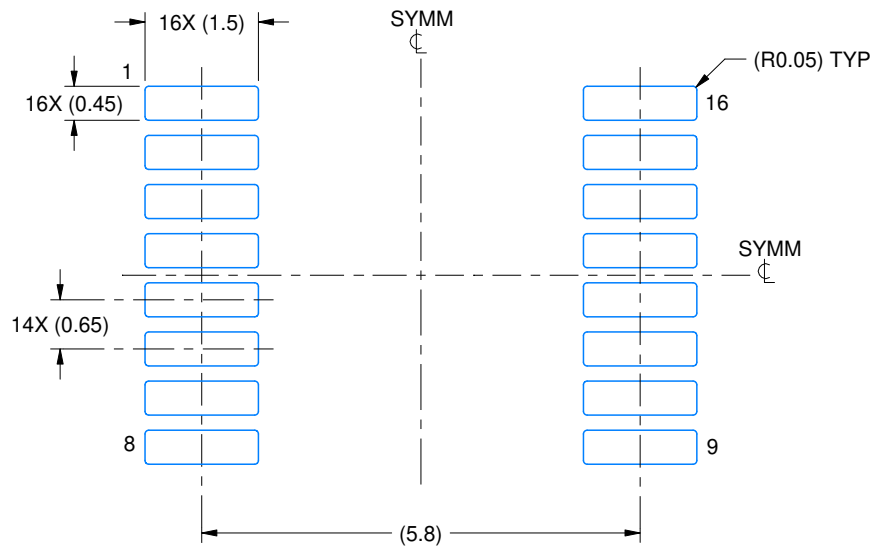

LAND PATTERN EXAMPLE
EXPOSED METAL SHOWN
SCALE: 10X

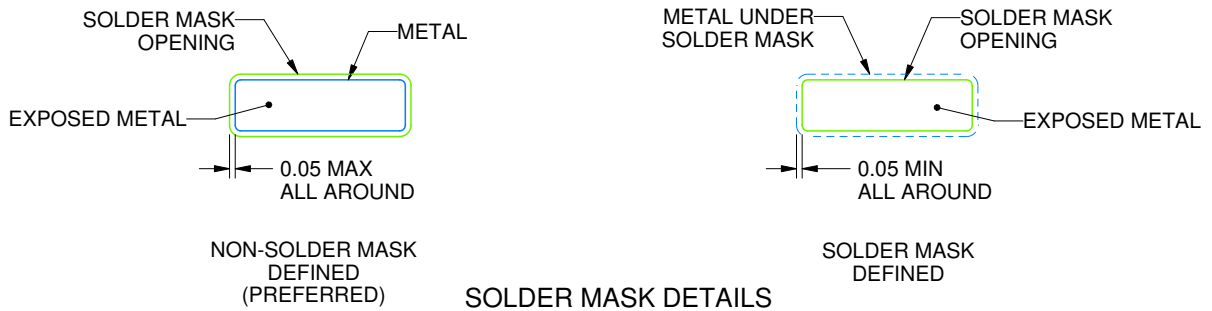

SOLDER MASK DETAILS

4220204/B 12/2023

NOTES: (continued)

- 6. Publication IPC-7351 may have alternate designs.
- 7. Solder mask tolerances between and around signal pads can vary based on board fabrication site.

EXAMPLE STENCIL DESIGN

PW0016A

TSSOP - 1.2 mm max height

SMALL OUTLINE PACKAGE

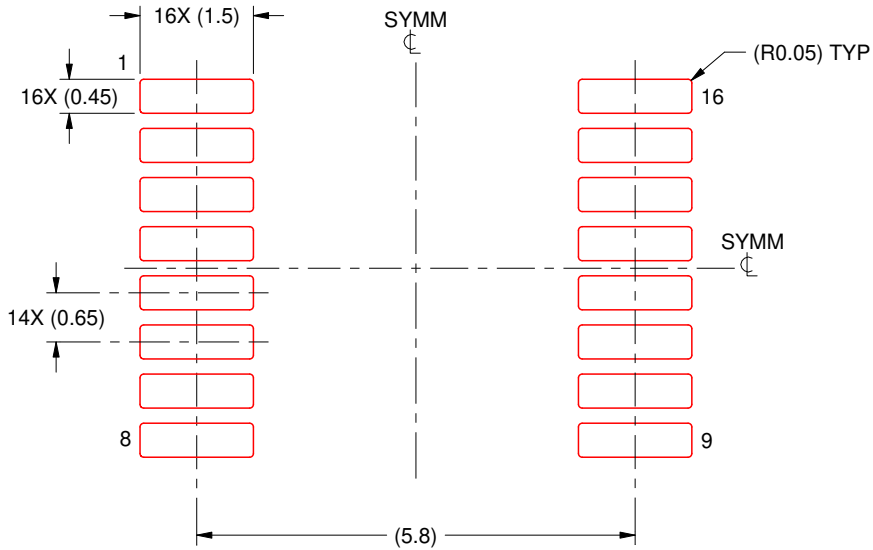

SOLDER PASTE EXAMPLE
BASED ON 0.125 mm THICK STENCIL
SCALE: 10X

4220204/B 12/2023

NOTES: (continued)

8. Laser cutting apertures with trapezoidal walls and rounded corners may offer better paste release. IPC-7525 may have alternate design recommendations.
9. Board assembly site may have different recommendations for stencil design.

N (R-PDIP-T**)

PLASTIC DUAL-IN-LINE PACKAGE

16 PINS SHOWN

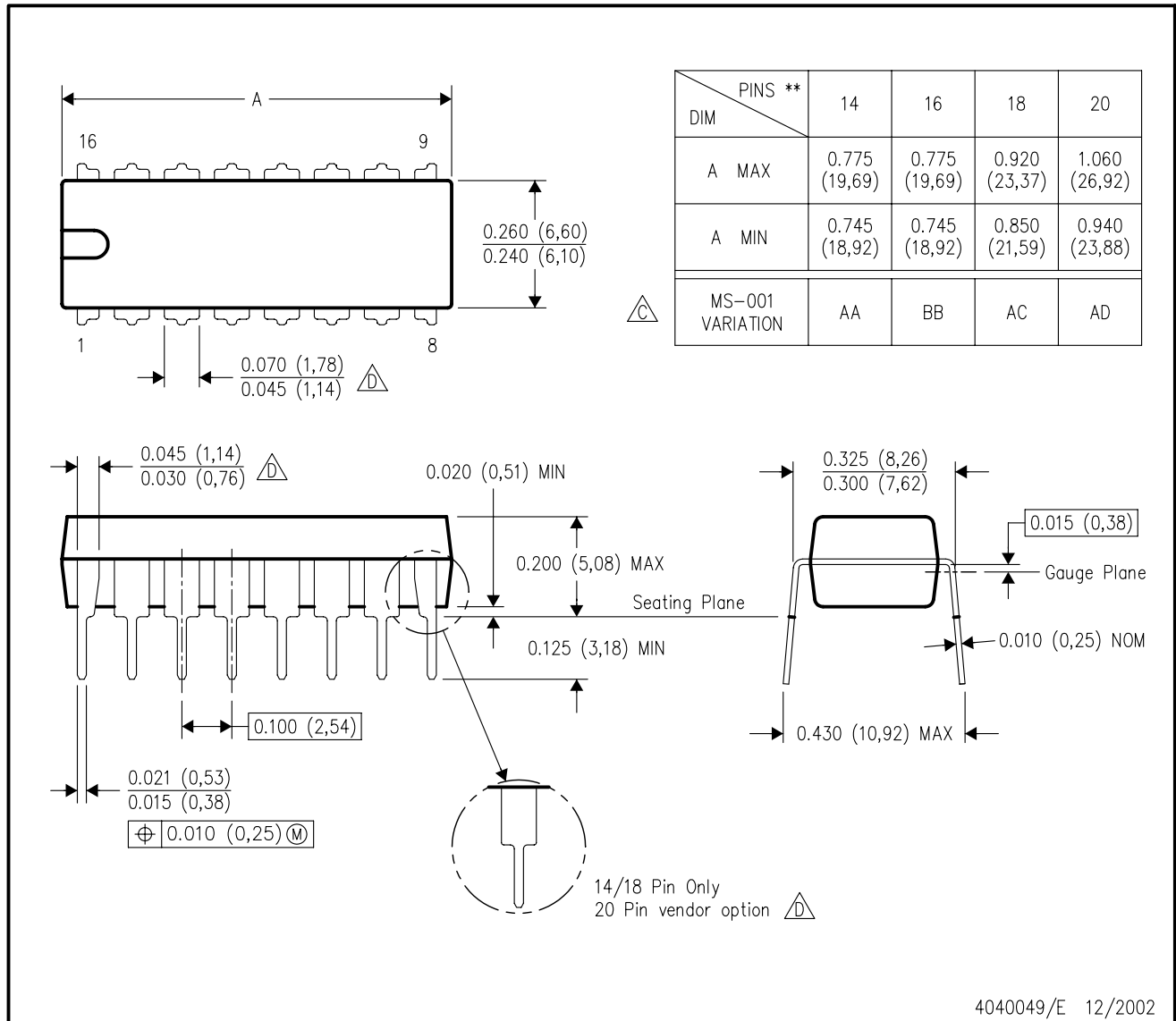

- NOTES:
- A. All linear dimensions are in inches (millimeters).
 - B. This drawing is subject to change without notice.
 - $\triangle C$ Falls within JEDEC MS-001, except 18 and 20 pin minimum body length (Dim A).
 - $\triangle D$ The 20 pin end lead shoulder width is a vendor option, either half or full width.

4040049/E 12/2002



PACKAGE OUTLINE

NS0016A

SOP - 2.00 mm max height

SOP

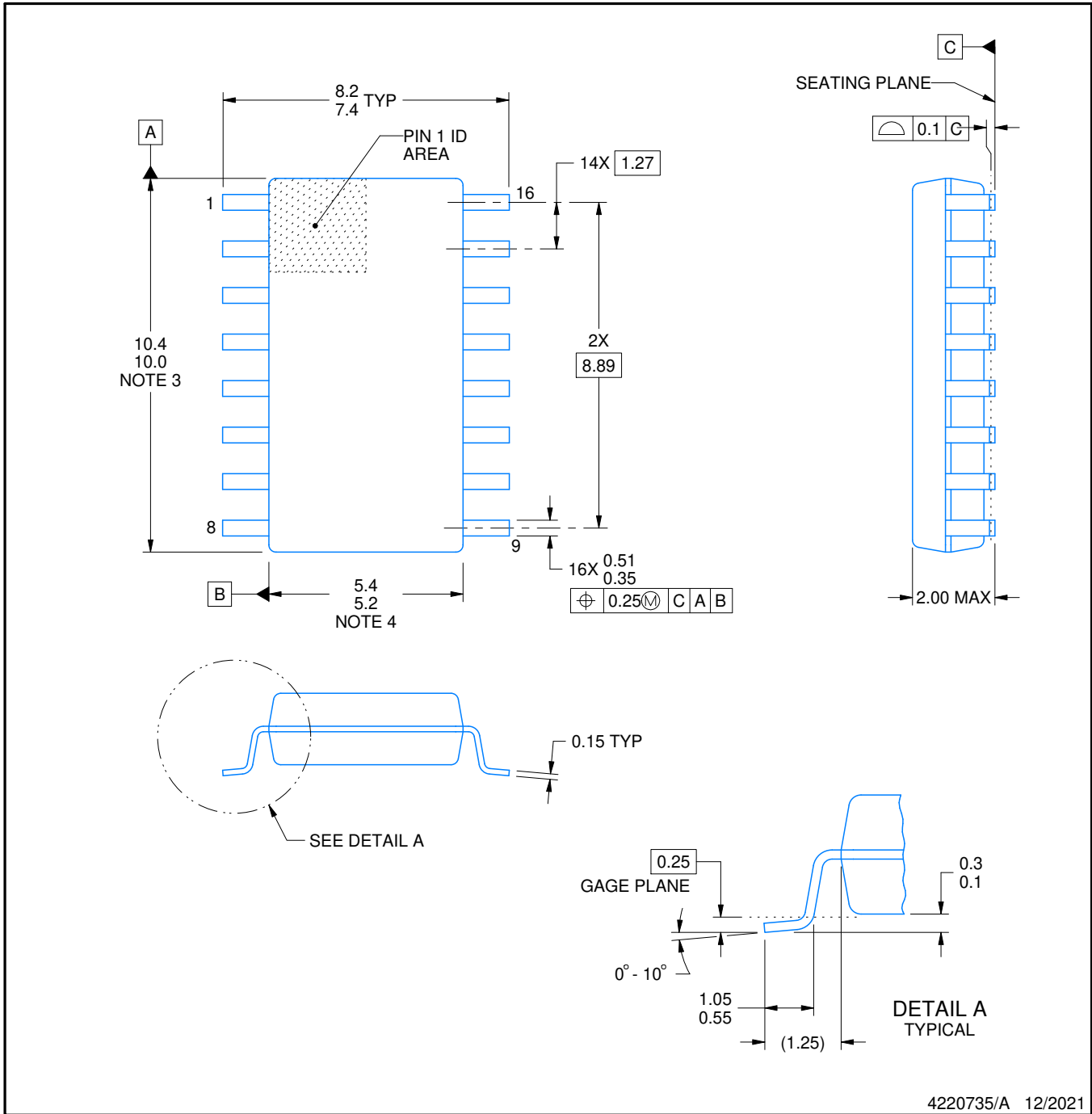

4220735/A 12/2021

NOTES:

1. All linear dimensions are in millimeters. Dimensions in parenthesis are for reference only. Dimensioning and tolerancing per ASME Y14.5M.
2. This drawing is subject to change without notice.
3. This dimension does not include mold flash, protrusions, or gate burrs. Mold flash, protrusions, or gate burrs shall not exceed 0.15 mm, per side.
4. This dimension does not include interlead flash. Interlead flash shall not exceed 0.25 mm, per side.

EXAMPLE BOARD LAYOUT

NS0016A

SOP - 2.00 mm max height

SOP

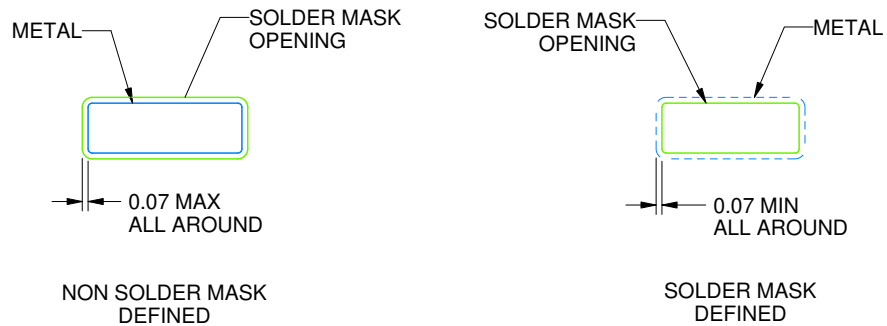
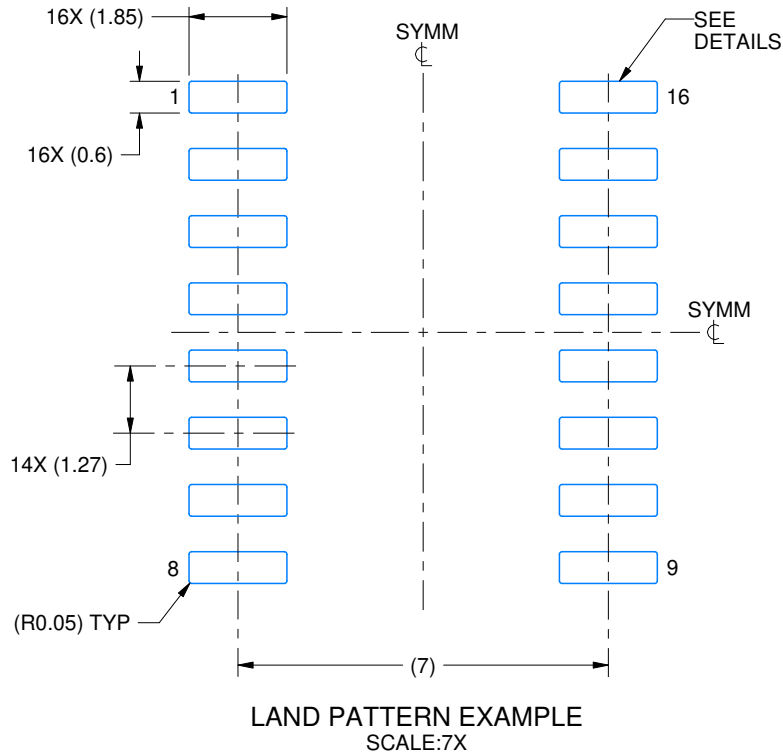

SOLDER MASK DETAILS

4220735/A 12/2021

NOTES: (continued)

5. Publication IPC-7351 may have alternate designs.

6. Solder mask tolerances between and around signal pads can vary based on board fabrication site.

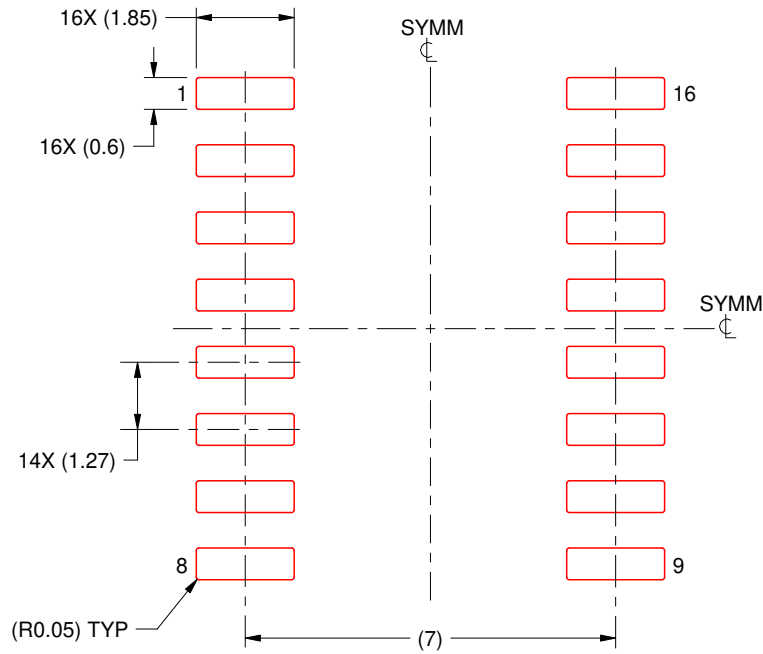

SOLDER PASTE EXAMPLE
BASED ON 0.125 mm THICK STENCIL
SCALE:7X

4220735/A 12/2021

NOTES: (continued)

7. Laser cutting apertures with trapezoidal walls and rounded corners may offer better paste release. IPC-7525 may have alternate design recommendations.
8. Board assembly site may have different recommendations for stencil design.

D (R-PDSO-G16)

PLASTIC SMALL OUTLINE

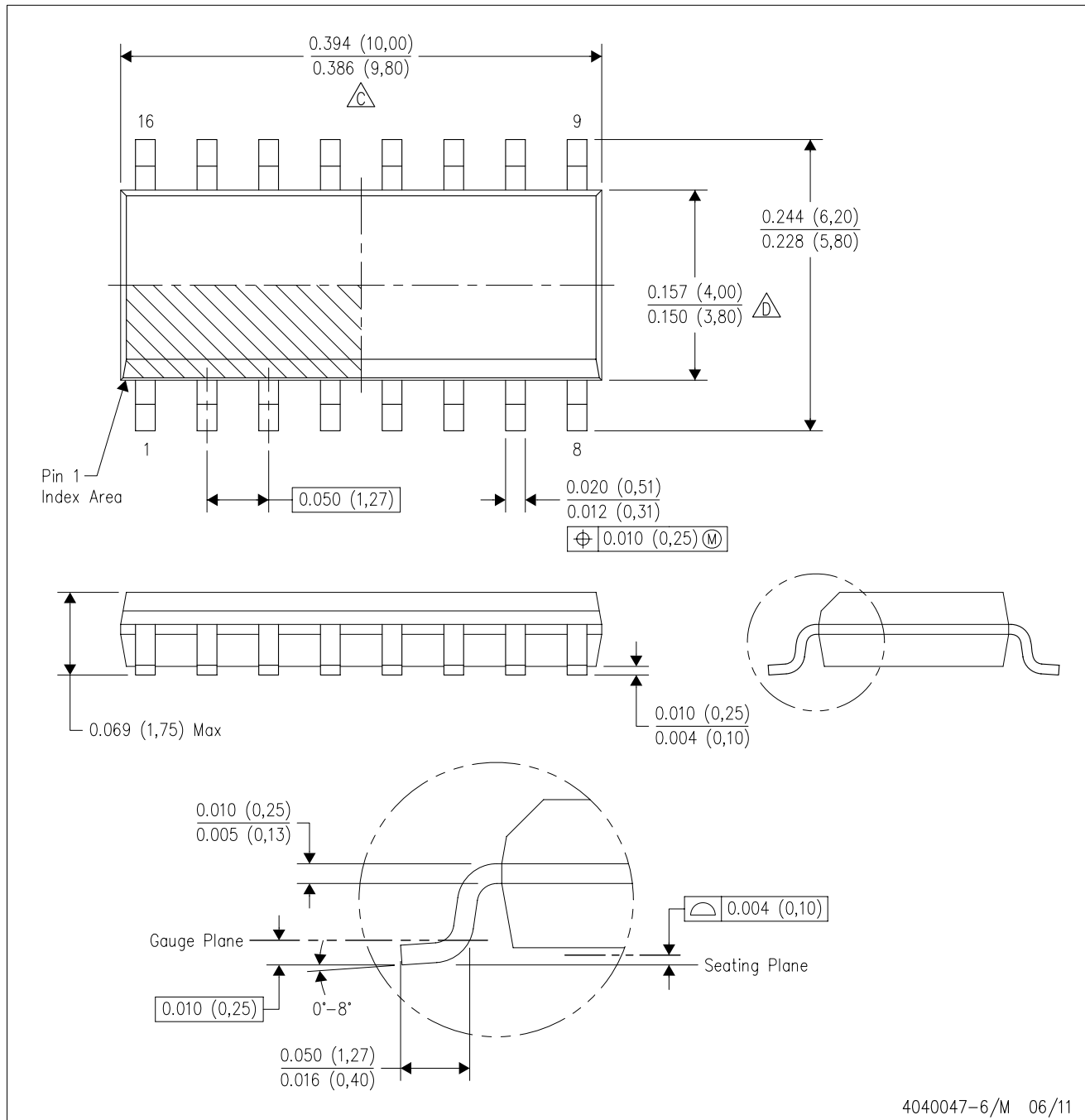

- NOTES:
- A. All linear dimensions are in inches (millimeters).
 - B. This drawing is subject to change without notice.
 - C. Body length does not include mold flash, protrusions, or gate burrs. Mold flash, protrusions, or gate burrs shall not exceed 0.006 (0,15) each side.
 - D. Body width does not include interlead flash. Interlead flash shall not exceed 0.017 (0,43) each side.
 - E. Reference JEDEC MS-012 variation AC.

IMPORTANT NOTICE AND DISCLAIMER

TI PROVIDES TECHNICAL AND RELIABILITY DATA (INCLUDING DATASHEETS), DESIGN RESOURCES (INCLUDING REFERENCE DESIGNS), APPLICATION OR OTHER DESIGN ADVICE, WEB TOOLS, SAFETY INFORMATION, AND OTHER RESOURCES "AS IS" AND WITH ALL FAULTS, AND DISCLAIMS ALL WARRANTIES, EXPRESS AND IMPLIED, INCLUDING WITHOUT LIMITATION ANY IMPLIED WARRANTIES OF MERCHANTABILITY, FITNESS FOR A PARTICULAR PURPOSE OR NON-INFRINGEMENT OF THIRD PARTY INTELLECTUAL PROPERTY RIGHTS.

These resources are intended for skilled developers designing with TI products. You are solely responsible for (1) selecting the appropriate TI products for your application, (2) designing, validating and testing your application, and (3) ensuring your application meets applicable standards, and any other safety, security, regulatory or other requirements.

These resources are subject to change without notice. TI grants you permission to use these resources only for development of an application that uses the TI products described in the resource. Other reproduction and display of these resources is prohibited. No license is granted to any other TI intellectual property right or to any third party intellectual property right. TI disclaims responsibility for, and you fully indemnify TI and its representatives against any claims, damages, costs, losses, and liabilities arising out of your use of these resources.

TI's products are provided subject to [TI's Terms of Sale](#), [TI's General Quality Guidelines](#), or other applicable terms available either on ti.com or provided in conjunction with such TI products. TI's provision of these resources does not expand or otherwise alter TI's applicable warranties or warranty disclaimers for TI products. Unless TI explicitly designates a product as custom or customer-specified, TI products are standard, catalog, general purpose devices.

TI objects to and rejects any additional or different terms you may propose.

Copyright © 2026, Texas Instruments Incorporated

Last updated 10/2025