



**HESTORE.HU**

elektronikai alkatrész áruház

**EN:** This Datasheet is presented by the manufacturer.

Please visit our website for pricing and availability at [www.hestore.hu](http://www.hestore.hu).



## 600mA Standalone Linear Li-Ion Battery Charger

### General Description

The LP4054H is a complete constant-current/constant-voltage linear charger for single cell lithium-ion batteries. Its SOT23-5 package and low external component count make the LP4054H ideally suited for portable applications. Furthermore, the LP4054H is specifically designed to work within USB power specifications. No external sense resistor is needed, and no blocking diode is required due to the internal MOSFET architecture. Thermal feedback regulates the charge current to limit the die temperature during high power operation or high ambient temperature. The charge voltage is fixed at 4.2V, and the charge current can be programmed externally with a single resistor. The LP4054H automatically terminates the charge cycle when the charge current drops to 1.5/10th the programmed value after the final float voltage is reached. When the input supply (wall adapter or USB supply) is removed, the LP4054H automatically enters a low current state, dropping the battery drain current to less than 1µA. Other features include charge current monitor, automatic recharge and a status pin to indicate charge termination and the presence of an input voltage.

### Features

- ◆ Programmable Charge Current Up to 600mA
- ◆ No MOSFET, Sense Resistor or Blocking Diode Required
- ◆ Constant-Current/Constant-Voltage Operation with Thermal Regulation to Maximize
- ◆ Charge Rate Without Risk of Overheating
- ◆ 4.2V Charge Voltage with ± 1% Accuracy
- ◆ Charge Current Monitor Output for Gas Gauging
- ◆ Automatic Recharge
- ◆ 3V Trickle Charge Threshold
- ◆ Charging OTP
- ◆ Package in SOT23-5/SOT23-6

### Typical Application Circuit

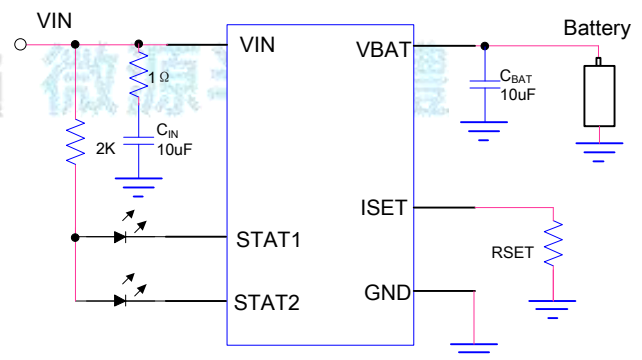

### Order Information

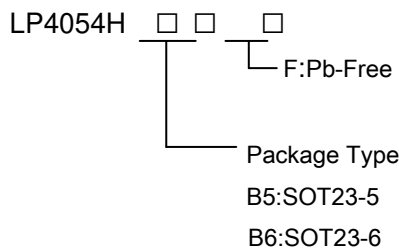

### Applications

- ◇ Portable Media Players/MP3 players
- ◇ Cellular and Smart mobile phone
- ◇ PDA/DSC
- ◇ Bluetooth Applications

### Marking Information

Part	Marking	Package	Shipping
LP4054HB5F	LP4054 HYWX	SOT23-5	3K/REEL
LP4054HB6F	LP4054 HYWX	SOT23-6	3K/REEL

Marking indication:

Y:Production year W:Production week X:Production batch.



## Functional Pin Description

Package Type	SOT23-5	SOT23-6
Pin Configurations	<p>Top View</p>	<p>Top View</p>

Pin		Name	Description
SOT23-5	SOT23-6		
1	1	STAT1	Open-Drain Charge Status Output. When the battery is charging, the STAT pin is pulled low by an internal N-channel MOSFET. When the charge cycle is completed, the pin is pulled High.
2	2	GND	Ground.
3	3	BAT	Charge Current Output. Provides charge current to the battery and regulates the final float voltage to 4.2V.
4	4	VIN	Positive Input Supply Voltage.
	5	STAT2	Open-Drain Charge Status Output. When the battery is charging, the STAT pin is pulled High by an internal N-channel MOSFET. When the charge cycle is completed, the pin is pulled Low.
5	6	ISET	Charge Current Program and Charge Current Monitor Pin. The charge current is programmed by connecting a 1% resistor, $R_{ISET}$ , to ground. When charging in constant-current mode, this pin serves to 1V. In all modes, the voltage on this pin can be used to measure the charge current using the following formula: $I_{BAT} = 1000 / R_{ISET}$



### Function Block Diagram

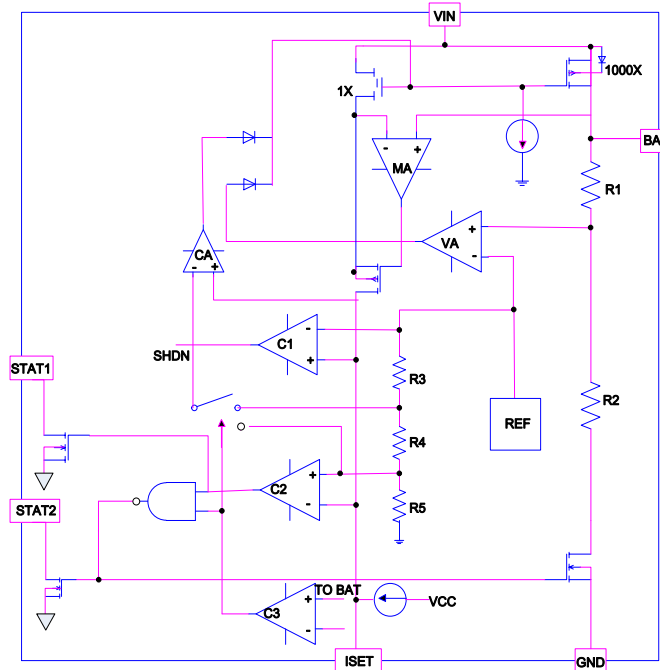

### Absolute Maximum Ratings <sup>Note1</sup>

- ✧ Input to GND(VIN) ----- -0.3V to 8V
- ✧ Other Pin to GND ----- -0.3V to 6V
- ✧ BAT Short-circuit Duration ----- Continuous
- ✧ Maximum Junction Temperature ----- 125°C
- ✧ Operating Junction Temperature Range (TJ) ----- -20°C to 85°C
- ✧ Maximum Soldering Temperature (at leads, 10 sec) ----- 260°C

**Note1.** Stresses beyond those listed under “Absolute Maximum Ratings” may cause permanent damage to the device. Exposure to absolute maximum rating conditions for extended periods may affect device reliability.

### Thermal Information

- ✧ Maximum Power Dissipation (SOT23-5, PD, T<sub>A</sub>=25°C) ----- 0.45W
- ✧ Thermal Resistance (SJA) ----- 250°C/W

### ESD Susceptibility

- ✧ HBM(Human Body Mode) ----- 2KV
- ✧ MM(Machine Mode) ----- 200V



## Electrical Characteristics

( $T_A = 25^\circ\text{C}$ .  $V_{IN} = 5\text{V}$ , unless otherwise noted.)

SYMBOL	PARAMETER	CONDITIONS	MIN	TYP.	MAX	UNITS
$V_{IN}$	Adapter/USB Voltage Range		4.5	5	6.5	V
$I_{IN}$	Input Supply Current	Standby Mode (Charge Terminated)		50		$\mu\text{A}$
$V_{FLOAT}$	Regulated Output (Float) Voltage	$I_{BAT} = 40\text{mA}$	4.158	4.2	4.242	V
$I_{BAT}$	BAT Pin Current	$R_{ISET} = 10\text{K}$ , Current Mode		100		mA
		$R_{ISET} = 2\text{K}$ , Current Mode		500		
		Standby Mode, $V_{BAT} = 4.2\text{V}$ Sleep Mode, $V_{IN} = 0\text{V}$		$\pm 1$		$\mu\text{A}$
$V_{TRIKL}$	Trickle Charge Threshold Voltage	$R_{ISET} = 10\text{K}$ , $V_{BAT}$ Rising		3		V
$V_{TRHYS}$	Trickle Charge Hysteresis Voltage	$R_{ISET} = 10\text{K}$		150		mV
$I_{TRIKL}$	Trickle charge current	$V_{BAT} < V_{TRIKL}$ , $R_{ISET} = 10\text{K}$		40		mA
		$V_{BAT} < V_{TRIKL}$ , $R_{ISET} = 2\text{K}$		200		
$V_{UV}$	$V_{IN}$ Undervoltage Lockout Threshold	From $V_{IN}$ Low to High		3.8		V
$V_{UVHYS}$	$V_{IN}$ Undervoltage Lockout Hysteresis			200		mV
$V_{ASD}$	$V_{IN} - V_{BAT}$ Lockout Threshold Voltage			150		mV
$I_{TERM}$	C/10 Termination Current Threshold			15		% $I_{BAT}$
$V_{ISET}$	ISET Pin Voltage	$R_{ISET} = 10\text{K}$ , Charge Mode		1		V
$V_{STAT}$	STAT1/STAT2 Pin Output Low Voltage	$I_{STAT} = 5\text{mA}$			0.5	V
$I_{STAT}$	STAT1/2 Pin Weak Pull-Down Current	$I_{CHRG} = 5\text{V}$			5	$\mu\text{A}$
$\Delta V_{RECHRG}$	Recharge Battery Threshold Voltage	$V_{FLOAT} - V_{RECHRG}$		200		mV



## Applications Information

The LP4054H is a single cell lithium-ion battery charger using a constant-current/constant-voltage algorithm. It can deliver up to 600mA of charge current (using a good thermal PCB layout) with a final float voltage accuracy of  $\pm 1\%$ . The LP4054H includes an internal P-channel power MOSFET and thermal regulation circuitry. No blocking diode or external current sense resistor is required; thus, the basic charger circuit requires only three external components. Furthermore, the LP4054H is capable of operating from a USB power source.

### Normal Charge Cycle

A charge cycle begins when the voltage at the VIN pin rises above the UVLO threshold level and a 1% program resistor is connected from the ISET pin to ground or when a battery is connected to the charger output. If the BAT pin is less than 2.9V, the charger enters trickle charge mode.

When the BAT pin voltage rises above 2.9V, the charger enters constant-current mode, where the programmed charge current is supplied to the battery. When the BAT pin approaches the final float voltage (4.2V), the LP4054H enters constant-voltage mode and the charge current begins to decrease. When the charge current drops to 1.5/10 of the programmed value the charge cycle ends.

### Programming Charge Current

The charge current is programmed using a single resistor from the ISET pin to ground. The battery charge current is 1000 times the current out of the ISET pin. The program resistor and the charge current are calculated using the following equations:

$$R_{ISET} = 1000 \div I_{BAT}$$

$$I_{BAT} = 1000 \div R_{ISET}$$

The charge current out of the BAT pin can be determined at any time by monitoring the ISET pin voltage using the following equation:

$$I_{BAT} = V_{ISET} \div R_{ISET} \times 1000$$

### Charge Status Indicator (CHRG)

The charge status output has two different states: strong pull-down ( $\sim 5\text{mA}$ ) and high impedance. The strong pull-down state indicates that the LP4054H is in a charge cycle. High impedance indicates that the charge cycle complete or the LP4054H is in under voltage lockout mode: either  $V_{IN}$  is less than 150mV above the BAT pin voltage or insufficient voltage is applied to the VIN pin. A microprocessor can be used to distinguish between these two states.

Charge Stage	STAT1 Status	STAT2 Status
Charging	Low	High
Charge Complete	High	Low

### Charge Termination

A charge cycle is terminated when the charge current falls to 1.5/10th the programmed value after the final float voltage is reached. This condition is detected by using an internal, filtered comparator to monitor the ISET pin. When the ISET pin voltage falls below 100mV for longer than  $T_{TERM}$  (typically 1ms), charging is terminated. The charge current is latched off and the LP4054H enters standby mode, where the input supply current drops to 50 $\mu\text{A}$ . When charging, transient loads on the BAT pin can cause the ISET pin to fall below 150mV for short periods of time before the DC charge current has dropped to 1.5/10th the programmed value. The 1ms filter time ( $T_{TERM}$ ) on the termination comparator ensures that transient loads of this nature do not result in premature charge cycle termination. Once the average charge current drops below 1.5/10th the programmed value, the LP4054H terminates the charge cycle and ceases to provide any current through the BAT pin. In this state, all loads on the BAT pin must be supplied by the battery. The LP4054H constantly monitors the BAT pin voltage in standby mode. If this voltage drops below the 4.0V recharge threshold ( $V_{RECHRG}$ ), another charge cycle begins and current is once again supplied to the battery. To manually restart a charge cycle when in standby mode, the input voltage must be removed and reapplied.



### Thermal Limit

An internal thermal feedback loop reduces the programmed charge current if the die temperature attempts to rise above a preset value of approximately 125°C. This feature protects the LP4054H from excessive temperature and allows the user to push the limits of the power handling capability of a given circuit board without risk of damaging the LP4054H. The charge current can be set according to typical (not worst-case) ambient temperature with the assurance that the charger will automatically reduce the current in worst-case conditions.

### Automatic Recharge

Once the charge cycle is terminated, the LP4054H continuously monitors the voltage on the BAT pin using a comparator with a 2ms filter time ( $T_{RECHARGE}$ ). A charge cycle restarts when the battery voltage falls below 4.0V (which corresponds to approximately 80% to 90% battery capacity). This ensures that the battery is kept at or near a fully charged condition and eliminates the need for periodic charge cycle initiations. CHRG output enters a strong pull-down state during recharge cycles.

### Power Dissipation

The conditions that cause the LP4054H to reduce charge current through thermal feedback can be approximated by considering the power dissipated in the IC. Nearly all of this power dissipation is generated by the internal MOSFET—this is calculated to be approximately:

$$PD=(V_{IN} - V_{BAT}) \times I_{BAT}$$

### VIN Bypass Capacitor

Many types of capacitors can be used for input bypassing; however, caution must be exercised when using multilayer ceramic capacitors. Because of the self-resonant and high Q characteristics of some types of ceramic capacitors, high voltage transients can be generated under some start-up conditions, such as connecting the charger input to a live power source. Adding a 1.5Ω resistor in series with an X5R ceramic capacitor will minimize start-up voltage transients.

### Layout Considerations

- ✧ For the main current paths as indicated in bold lines, keep their traces short and wide.
- ✧ Put the input capacitor as close as possible to the device pins (VIN and GND).
- ✧ Connect all analog grounds to a command node and then connect the command node to the power ground behind the output capacitors.



### Packaging Information

#### SOT23-5

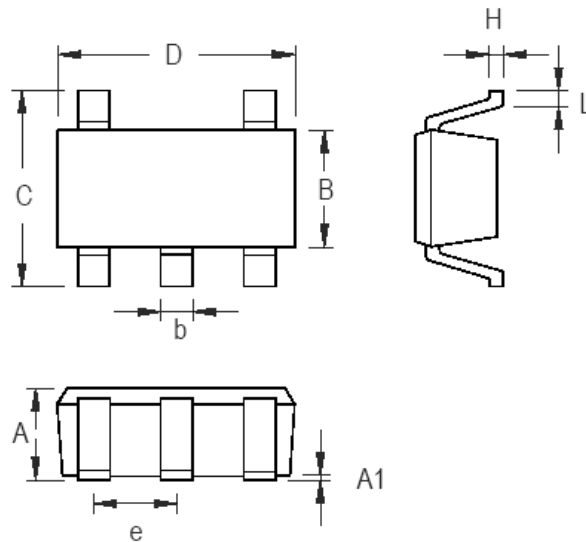

Symbol	Dimensions In Millimeters		Dimensions In Inches	
	Min	Max	Min	Max
A	0.889	1.295	0.035	0.051
A1	0.000	0.152	0.000	0.006
B	1.397	1.803	0.055	0.071
b	0.356	0.559	0.014	0.022
C	2.591	2.997	0.102	0.118
D	2.692	3.099	0.106	0.122
e	0.838	1.041	0.033	0.041
H	0.080	0.254	0.003	0.010
L	0.300	0.610	0.012	0.024

#### SOT-23-5 Surface Mount Package



SOT23-6

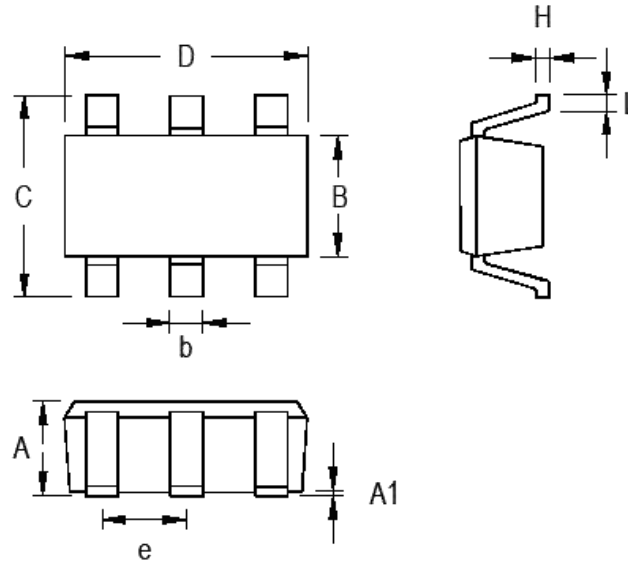

Symbol	Dimensions In Millimeters		Dimensions In Inches	
	Min	Max	Min	Max
A	0.889	1.295	0.031	0.051
A1	0.000	0.152	0.000	0.006
B	1.397	1.803	0.055	0.071
b	0.250	0.560	0.010	0.022
C	2.591	2.997	0.102	0.118
D	2.692	3.099	0.106	0.122
e	0.838	1.041	0.033	0.041
H	0.080	0.254	0.003	0.010
L	0.300	0.610	0.012	0.024