



**HESTORE.HU**

elektronikai alkatrész áruház

**EN:** This Datasheet is presented by the manufacturer.

Please visit our website for pricing and availability at [www.hestore.hu](http://www.hestore.hu).



# TF2101M

## High-Side and Low-Side Gate Driver

### Features

- Floating high-side driver in bootstrap operation to 600V
- Drives two N-channel MOSFETs or IGBTs in high-side/low-side configuration
- Outputs tolerant to negative transients
- Wide low-side gate driver and logic supply: 10V to 20V
- Logic inputs CMOS and TTL compatible (down to 3.3V)
- Schmitt triggered logic inputs with internal pull down
- Undervoltage lockout for  $V_{CC}$
- Space-saving SOIC-8 package available
- Extended temperature range: -40°C to +125°C

### Applications

- DC-DC Converters
- AC-DC Inverters
- Motor Controls
- Class D Power Amplifiers

### Typical Application

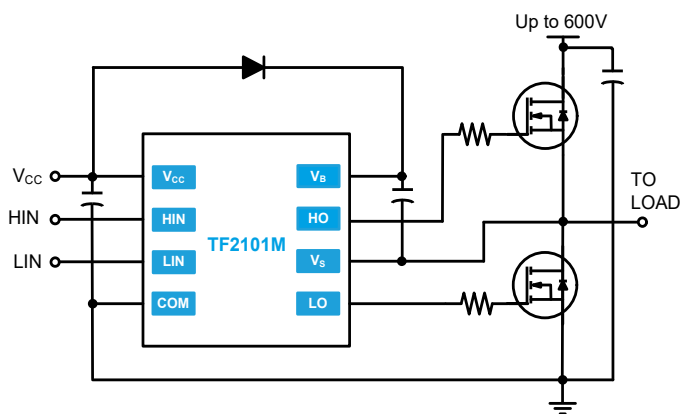

### Description

The TF2101M is a high voltage, high speed gate driver capable of driving N-channel MOSFETs and IGBTs in a high-side/low-side configuration. TF Semiconductor's high voltage process enables the TF2101M's high-side to switch to 600V in a bootstrap operation. The 50ns (max) propagation delay matching between the high and the low side drivers allows high frequency switching.

The TF2101M logic inputs are compatible with standard TTL and CMOS levels (down to 3.3V) for easy interfacing with controlling devices. The driver outputs feature high pulse current buffers designed for minimum driver cross conduction. The low-side gate driver and logic share a common ground

The TF2101M is available in a space-saving 8-pin SOIC package and an 8-pin PDIP; the operating temperature extends from -40°C to +125°C.



SOIC-8(N)

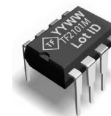

PDIP-8

### Ordering Information

Year Year Week Week

PART NUMBER	PACKAGE	PACK / Qty	MARK
TF2101M-TAU	SOIC-8(N)	Tube / 100	TF YYWW TF2101M Lot ID
TF2101M-TAH	SOIC-8(N)	T & R / 2500	TF YYWW TF2101M Lot ID
TF2101M-3AS	PDIP-8	Tube / 50	TF YYWW TF2101M Lot ID

### Pin Diagrams

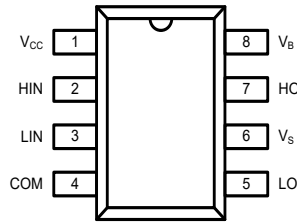

**Top View:** PDIP-8, SOIC-8

**TF2101M**

### Pin Descriptions

PIN NAME	PIN DESCRIPTION
HIN	Logic input for high-side gate driver output (HO), in phase
LIN	Logic input for low-side gate driver output (LO), in phase
V <sub>B</sub>	High-side floating supply
HO	High-side gate drive output
V <sub>S</sub>	High-side floating supply return
V <sub>CC</sub>	Low-side and logic fixed supply
LO	Low-side gate drive output
COM	Low-side return
NC	"No connect" pin

### Functional Block Diagram

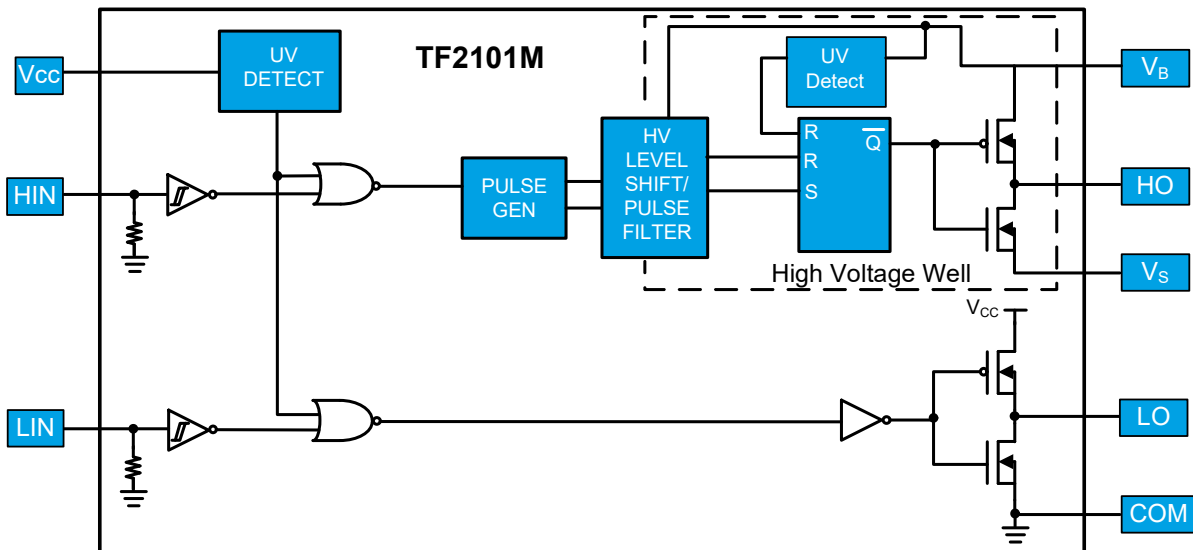

## Absolute Maximum Ratings *(NOTE1)*

$V_B$  - High side floating supply voltage.....-0.3V to +624V  
 $V_S$  - High side floating supply offset voltage... $V_B$ -24V to  $V_B$ +0.3V  
 $V_{HO}$  - High side floating output voltage..... $V_S$ -0.3V to  $V_B$ +0.3V  
 $dV_S / dt$  - Offset supply voltage transient.....50 V/ns

$V_{CC}$  - Low side and logic fixed supply voltage.....-0.3V to +24V  
 $V_{LO}$  - Low side output voltage.....-0.3V to  $V_{CC}$ +0.3V  
 $V_{IN}$  - Logic input voltage (HIN and LIN)... -0.3V to  $V_{CC}$ +0.3V

**NOTE1** Stresses beyond those listed under "Absolute Maximum Ratings" may cause permanent damage to the device. These are stress ratings only, and functional operation of the device at these or any other conditions beyond those indicated in the operational sections of the specifications is not implied. Exposure to absolute maximum rating conditions for extended periods may affect device reliability.

$P_D$  - Package power dissipation at  $T_A \leq 25^\circ\text{C}$   
 SOIC-8.....0.625W  
 PDIP-8.....1.0W

### SOIC-8 Thermal Resistance *(NOTE2)*

$\theta_{JC}$ .....45 °C/W  
 $\theta_{JA}$ .....200 °C/W

### PDIP-8 Thermal Resistance *(NOTE2)*

$\theta_{JC}$ .....35 °C/W  
 $\theta_{JA}$ .....125 °C/W

$T_J$  - Junction operating temperature .....+150 °C  
 $T_L$  - Lead temperature (soldering, 10s) ..... +300 °C  
 $T_{stg}$  - Storage temperature range .....-55 °C to +150 °C

**NOTE2** When mounted on a standard JEDEC 2-layer FR-4 board.

## Recommended Operating Conditions

Symbol	Parameter	MIN	TYP	MAX	Unit
$V_B$	High side floating supply absolute voltage	$V_S + 10$		$V_S + 20$	V
$V_S$	High side floating supply offset voltage	<b>NOTE3</b>		600	V
$V_{HO}$	High side floating output voltage	$V_S$		$V_B$	V
$V_{CC}$	Low side and logic fixed supply voltage	10		20	V
$V_{LO}$	Low side output voltage	0		$V_{CC}$	V
$V_{IN}$	Logic input voltage (HIN and LIN)	0		5	V
$T_A$	Ambient temperature	-40		125	°C

**NOTE3** Logic operational for  $V_S = -5$  to +600V.

## DC Electrical Characteristics (NOTE4)

$V_{BIAS} (V_{CC}, V_{BS}) = 15V, T_A = 25^\circ C$ , unless otherwise specified.

Symbol	Parameter	Conditions	MIN	TYP	MAX	Unit
$V_{IH}$	Logic "1" input voltage	$V_{CC} = 10V$ to $20V$	2.5			V
$V_{IL}$	Logic "0" input voltage	<b>NOTE5</b>			0.8	V
$V_{OH}$	High level output voltage, $V_{BIAS} - V_O$	$I_O = 2mA$		0.05	0.2	V
$V_{OL}$	Low level output voltage, $V_O$	$I_O = 2mA$		0.02	0.1	V
$I_{LK}$	Offset supply leakage current	$V_B = V_S = 600V$			50	$\mu A$
$I_{BSQ}$	Quiescent $V_{BS}$ supply current	$V_{IN} = 0V$ or $5V$		30	55	$\mu A$
$I_{CCQ}$	Quiescent $V_{CC}$ supply current	$V_{IN} = 0V$ or $5V$		150	270	$\mu A$
$I_{IN+}$	Logic "1" input bias current	$V_{IN} = 5V$		3	10	$\mu A$
$I_{IN-}$	Logic "0" input bias current	$V_{IN} = 0V$			5	$\mu A$
$V_{CCUV+}$	$V_{CC}$ supply under-voltage positive going threshold		8	8.9	9.8	V
$V_{CCUV-}$	$V_{CC}$ supply under-voltage negative going threshold		7.4	8.2	9	V
$I_{O+}$	Output high short circuit pulsed current	$V_O = 0V, V_{IN} = \text{Logic "1"}$ , $PW \leq 10 \mu s$	130	290		mA
$I_{O-}$	Output low short circuit pulsed current	$V_O = 15V, V_{IN} = \text{Logic "0"}$ , $PW \leq 10 \mu s$	270	600		mA

## AC Electrical Characteristics

$V_{BIAS} (V_{CC}, V_{BS}) = 15V, T_A = 25^\circ C$ , and  $C_L = 1000pF$ , unless otherwise specified.

Symbol	Parameter	Conditions	MIN	TYP	MAX	Unit
$t_{ON}$	Turn-on propagation delay	$V_S = 0V$		160	220	ns
$t_{OFF}$	Turn-off propagation delay	$V_S = 600V$		150	220	ns
$t_r$	Turn-on rise time			70	170	ns
$t_f$	Turn-off fall time			35	90	ns
$t_{DM}$	Delay matching				50	ns

**NOTE4** The  $V_{IH}$ ,  $V_{TH}$ , and  $I_{IN}$  parameters are referenced to COM. The  $V_O$  and  $I_O$  parameters are referenced to COM and are applicable to the respective output pins: HO and LO.

**NOTE5** For optimal operation, it is recommended that the input pulse (to HIN and LIN) should have an amplitude of 2.5V minimum with a pulse width of 300ns minimum

# Timing Waveforms

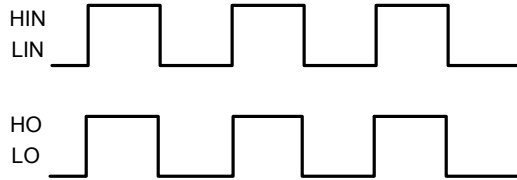

**Figure 1.** Input / Output Timing Diagram

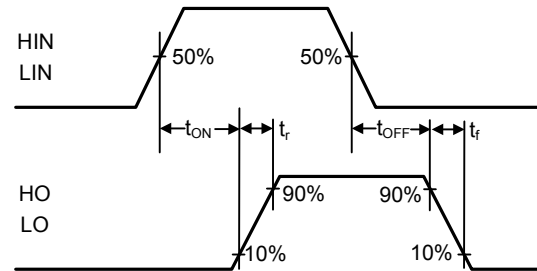

**Figure 2.** Switching Time Waveform Definitions

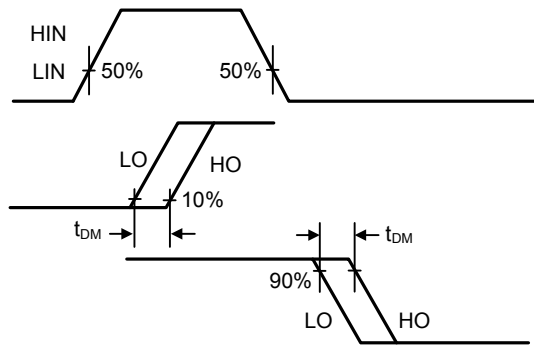

**Figure 3.** Delay Matching Waveform Definitions

Typical Characteristics

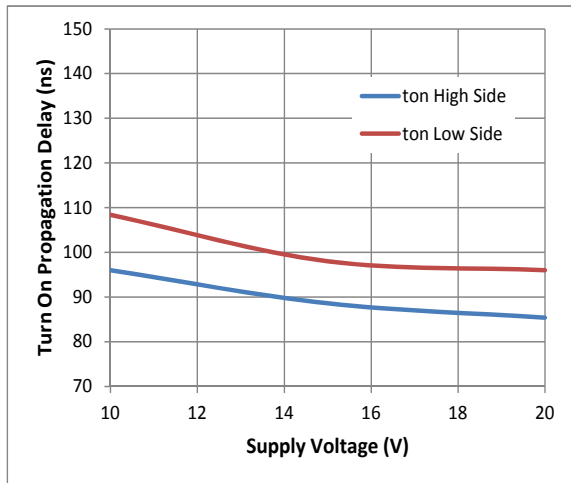

Figure 4. Turn-on Propagation Delay vs. Supply Voltage

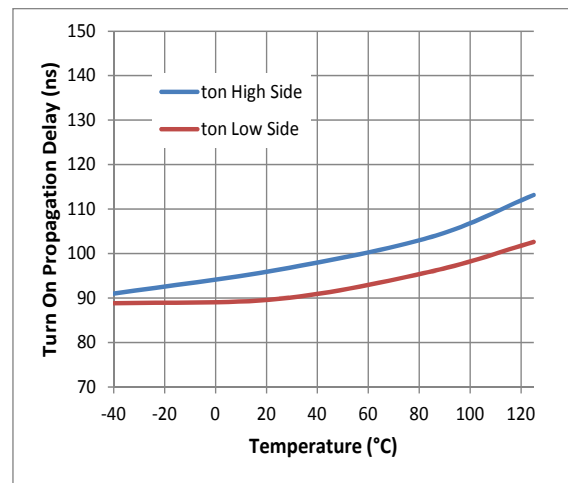

Figure 5. Turn-on Propagation Delay vs. Temperature

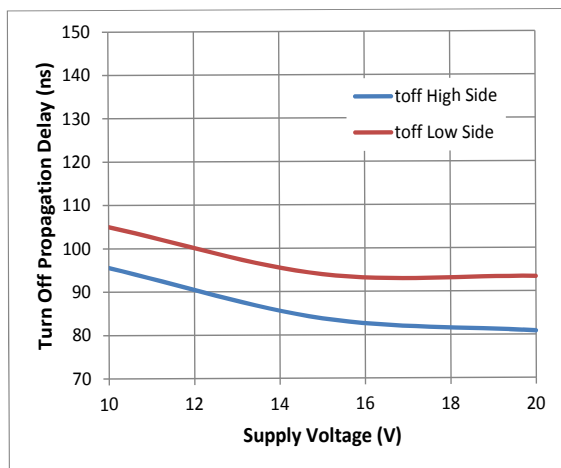

Figure 6. Turn-off Propagation Delay vs. Supply Voltage

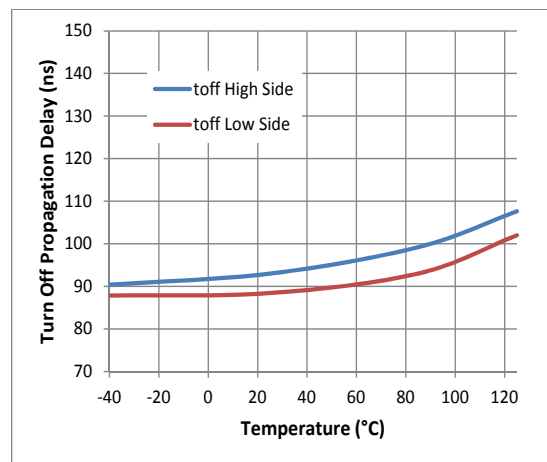

Figure 7. Turn-off Propagation Delay vs. Temperature

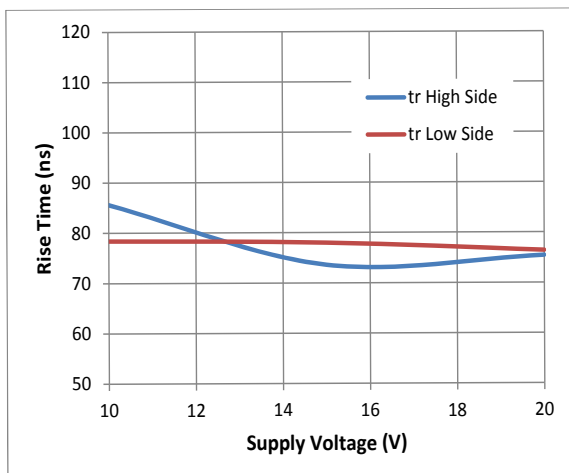

Figure 8. Rise Time vs. Supply Voltage

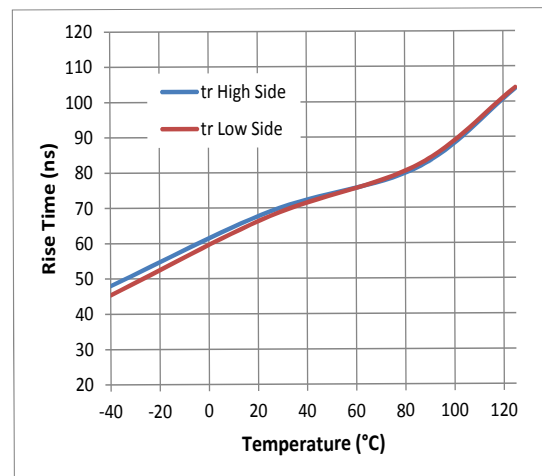

Figure 9. Rise Time vs. Temperature

Typical Characteristics, cont'd

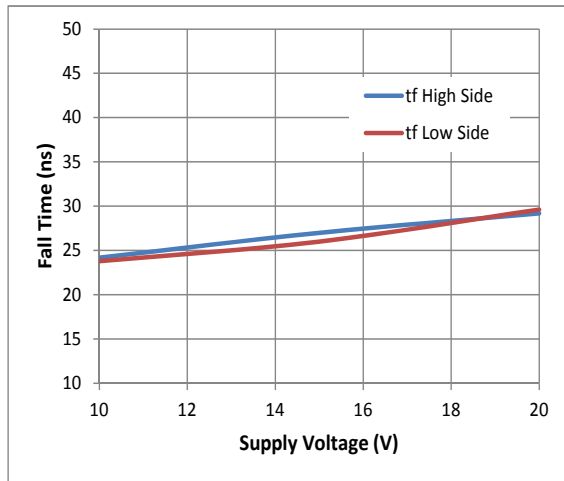

Figure 10. Fall Time vs. Supply Voltage

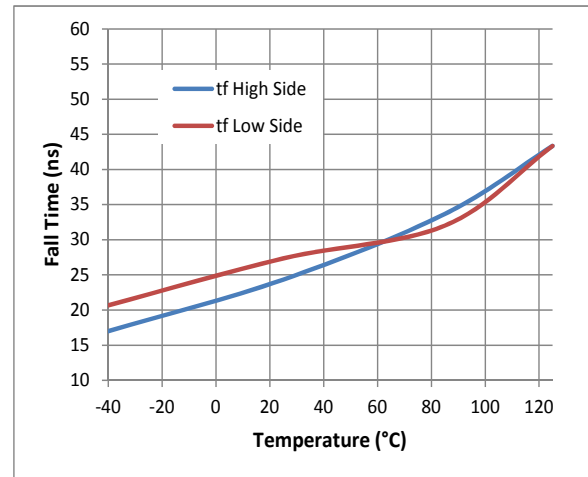

Figure 11. Fall Time vs. Temperature

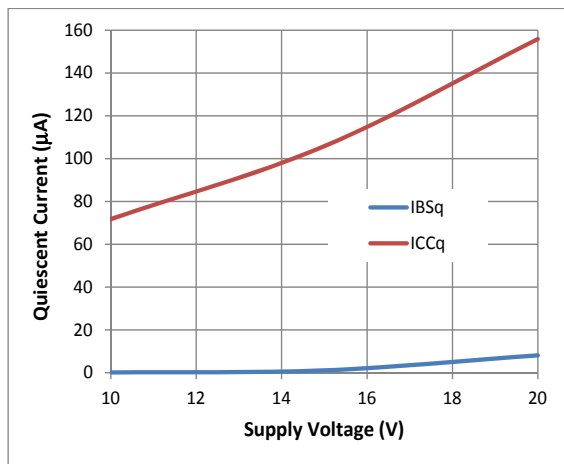

Figure 12. Quiescent Current vs. Supply Voltage

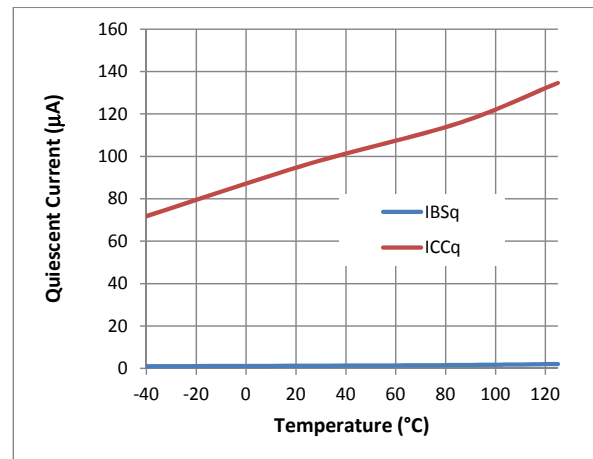

Figure 13. Quiescent Current vs. Temperature

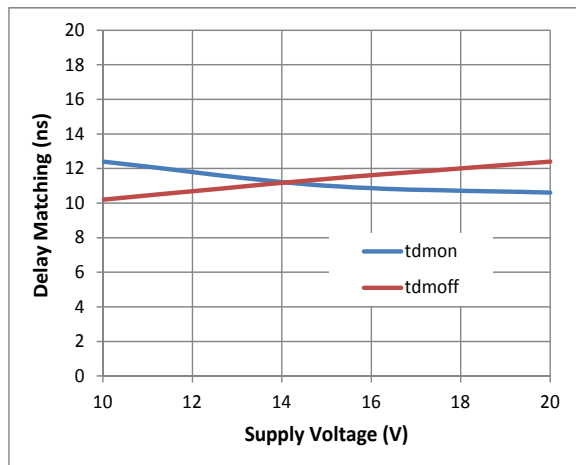

Figure 14. Delay Matching vs. Supply Voltage

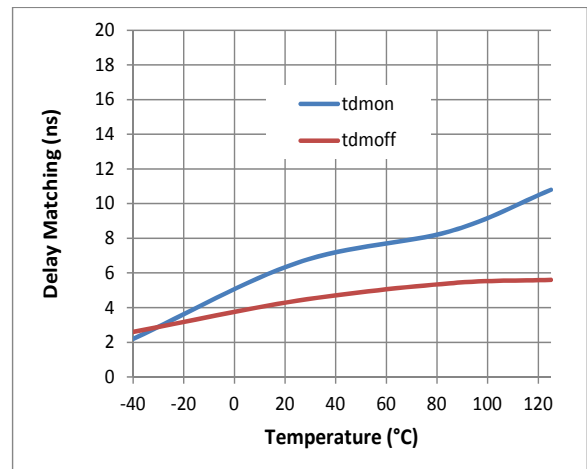

Figure 15. Delay Matching vs. Temperature



Typical Characteristics, cont'd

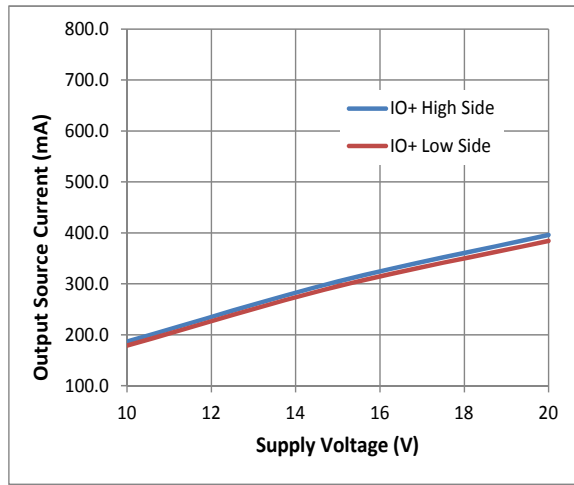

Figure 16. Output Source Current vs. Supply Voltage

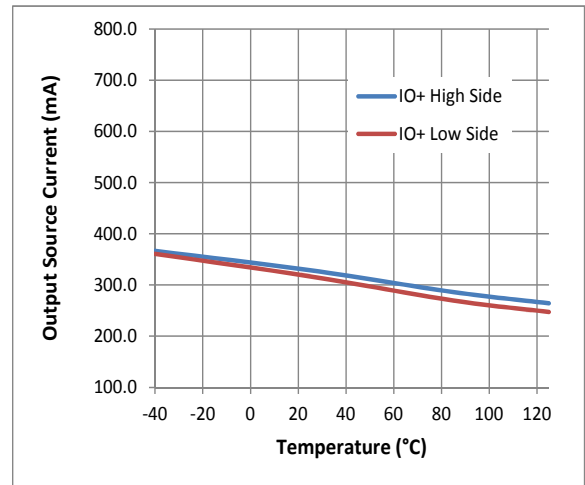

Figure 17. Output Source Current vs. Temperature

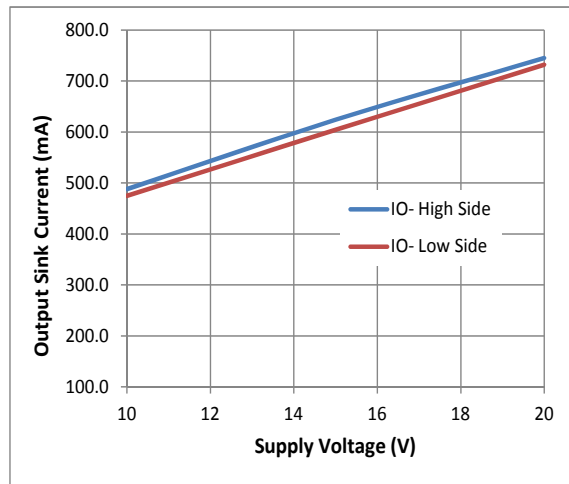

Figure 18. Output Sink Current vs. Supply Voltage

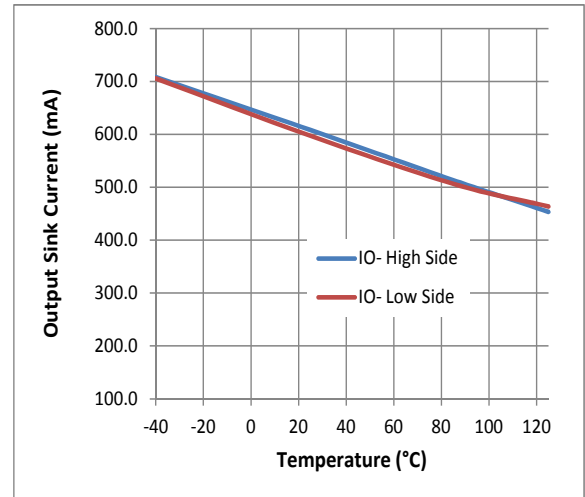

Figure 19. Output Sink Current vs. Temperature

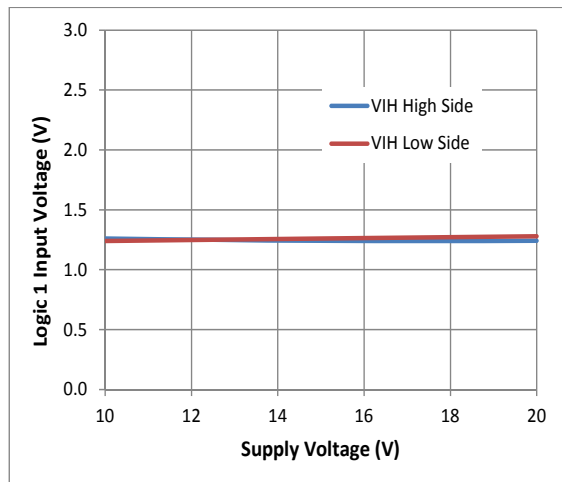

Figure 20. Logic 1 Input Voltage vs. Supply Voltage

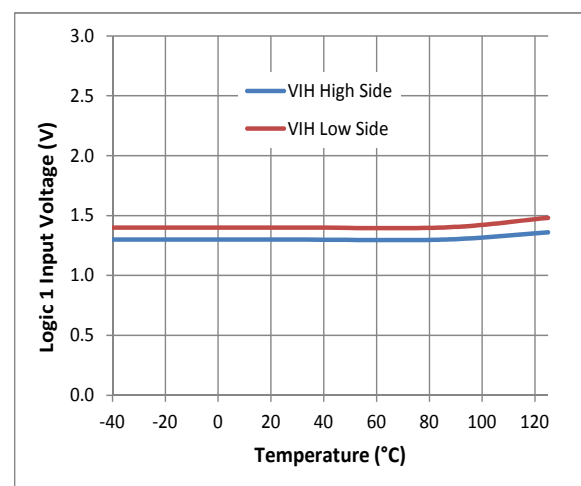

Figure 21. Logic 1 Input Voltage vs. Temperature

Typical Characteristics, cont'd

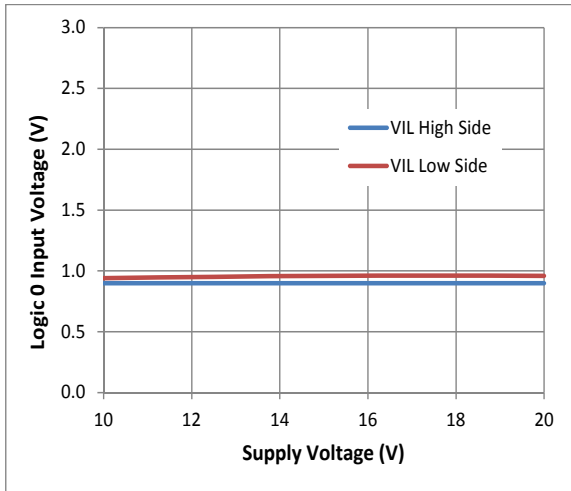

Figure 22. Logic 0 Input Voltage vs. Supply Voltage

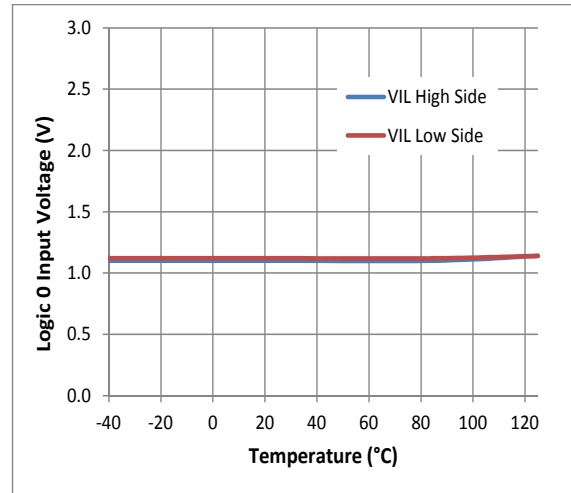

Figure 23. Logic 0 Input Voltage vs. Temperature

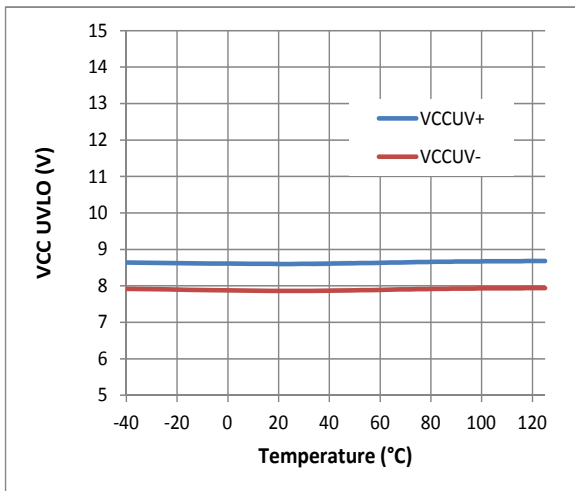

Figure 24.  $V_{CC}$  UVLO vs. Temperature

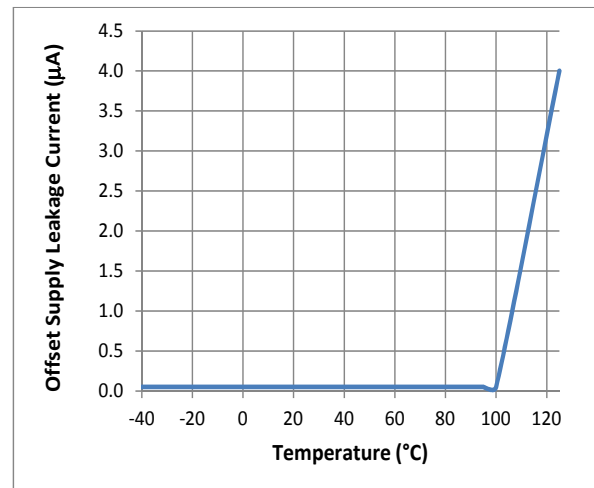
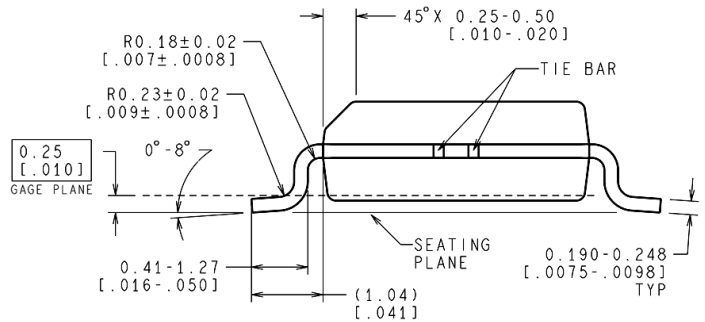
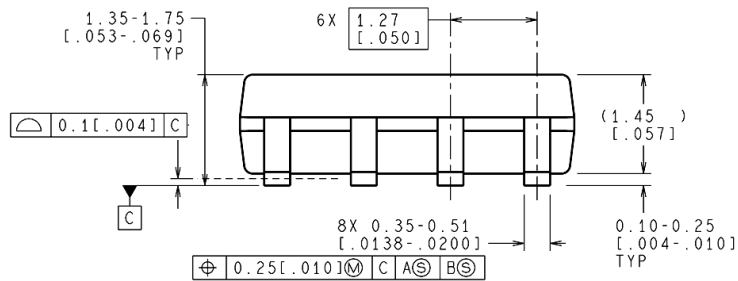
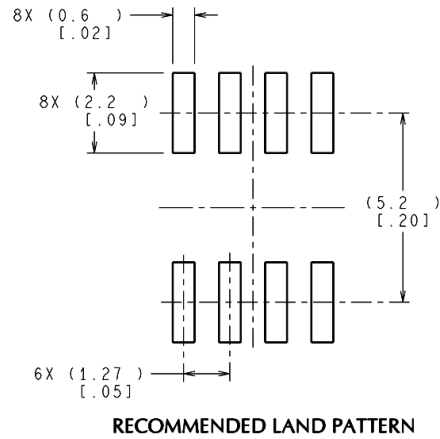
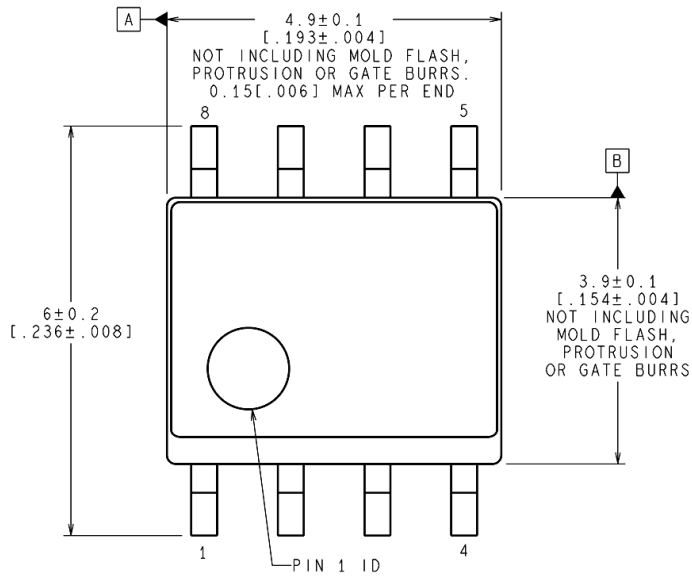

Figure 25. Offset Supply Leakage Current Temperature

# Package Dimensions (SOIC-8 N)

Please contact support@tfsemi.com for package availability.



NOTES: UNLESS OTHERWISE SPECIFIED

- REFERENCE JEDEC REGISTRATION MS-012, VARIATION AA.

**CONTROLLING DIMENSION IS MILLIMETER**  
**VALUES IN [ ] ARE INCHES**  
 DIMENSIONS IN ( ) FOR REFERENCE ONLY

Package Dimensions (PDIP-8)

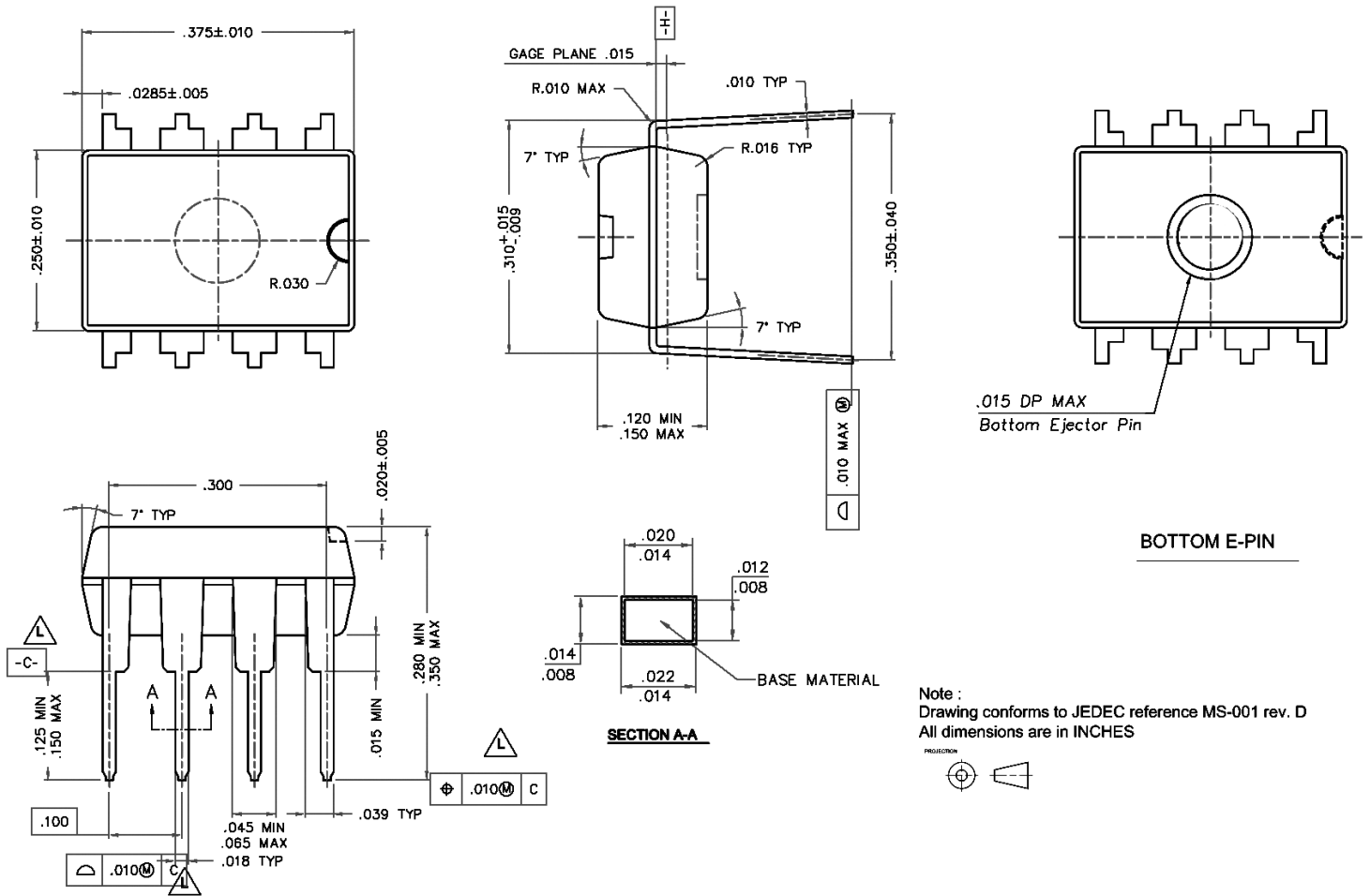

## Revision History

Rev.	Change	Owner	Date
1.0	First release	Keith Spaulding	4/20/2017
1.1	Add Note 5	Duke Walton	7/28/2019

## Important Notice

TF Semiconductor Solutions (TFSS) PRODUCTS ARE NEITHER DESIGNED NOR INTENDED FOR USE IN MILITARY AND/OR AEROSPACE, AUTOMOTIVE OR MEDICAL DEVICES OR SYSTEMS UNLESS THE SPECIFIC TFSS PRODUCTS ARE SPECIFICALLY DESIGNATED BY TFSS FOR SUCH USE. BUYERS ACKNOWLEDGE AND AGREE THAT ANY SUCH USE OF TFSS PRODUCTS WHICH TFSS HAS NOT DESIGNATED FOR USE IN MILITARY AND/OR AEROSPACE, AUTOMOTIVE OR MEDICAL DEVICES OR SYSTEMS IS SOLELY AT THE BUYER'S RISK.

TFSS assumes no liability for application assistance or customer product design. Customers are responsible for their products and applications using TFSS products.

Resale of TFSS products or services with statements different from or beyond the parameters stated by TFSS for that product or service voids all express and any implied warranties for the associated TFSS product or service. TFSS is not responsible or liable for any such statements.

©2019 TFSS. All Rights Reserved. Information and data in this document are owned by TFSS wholly and may not be edited, reproduced, or redistributed in any way without the express written consent from TFSS.

For additional information please contact [support@tfsemi.com](mailto:support@tfsemi.com) or visit [www.tfsemi.com](http://www.tfsemi.com)