



HESTORE.HU

elektronikai alkatrész áruház

EN: This Datasheet is presented by the manufacturer.

Please visit our website for pricing and availability at www.hestore.hu.

Ambient Light Sensor

Description

TEMT6000 is a silicon NPN epitaxial planar phototransistor in a miniature transparent mold for surface mounting onto a printed circuit board. The device is sensitive to the visible spectrum.

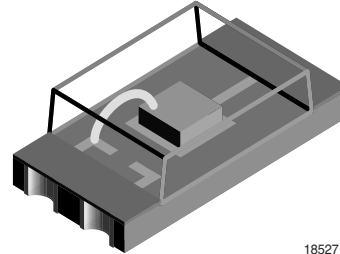

18527

Features

- Adapted to human eye responsivity
- Wide angle of half sensitivity $\phi = \pm 60^\circ$
- SMD style package on PCB technology
- Suitable for IR reflow soldering
- Lead free component
- Component in accordance to RoHS 2002/95/EC and WEEE 2002/96/EC

Applications

Ambient light sensor for display backlight dimming in:

Mobile phones

Notebook computers

PDA's

Cameras

Dashboards

Absolute Maximum Ratings

$T_{amb} = 25^\circ\text{C}$, unless otherwise specified

Parameter	Test condition	Symbol	Value	Unit
Collector Emitter Voltage		V_{CEO}	6	V
Emitter Collector Voltage		V_{ECO}	1.5	V
Collector current		I_C	20	mA
Total Power Dissipation	$T_{amb} \leq 55^\circ\text{C}$	P_{tot}	100	mW
Junction Temperature		T_j	100	$^\circ\text{C}$
Operating Temperature Range		T_{amb}	- 40 to + 85	$^\circ\text{C}$
Storage Temperature Range		T_{stg}	- 40 to + 85	$^\circ\text{C}$
Soldering Temperature	$t \leq 3\text{ s}$	T_{sd}	260	$^\circ\text{C}$
Thermal Resistance Junction/ Ambient		R_{thJA}	450	K/W

Basic Characteristics

$T_{amb} = 25\text{ }^{\circ}\text{C}$, unless otherwise specified

Parameter	Test condition	Symbol	Min	Typ.	Max	Unit
Collector Emitter Breakdown Voltage	$I_C = 0.1\text{ mA}$	V_{CEO}	6			V
Collector dark current	$V_{CE} = 5\text{ V}, E = 0$	I_{CEO}		3	50	nA
Collector-emitter capacitance	$V_{CE} = 0\text{ V}, f = 1\text{ MHz}, E = 0$	C_{CEO}		16		pF
Collector Light Current	$E_V = 20\text{ lx, standard light A}$	I_{ca}	3.5	10	16	μA
	$E_V = 100\text{ lx, standard light A}$	I_{ca}		50		μA
Angle of Half Sensitivity		ϕ		± 60		deg
Wavelength of Peak Sensitivity		λ_p		570		nm
Range of Spectral Bandwidth		$\lambda_{0.1}$		360 to 970		nm
Collector Emitter Saturation Voltage	$E_V = 20\text{ lx, } 0.45\text{ }\mu\text{A}$	V_{CEsat}		0.1		V

Typical Characteristics ($T_{amb} = 25\text{ }^{\circ}\text{C}$ unless otherwise specified)

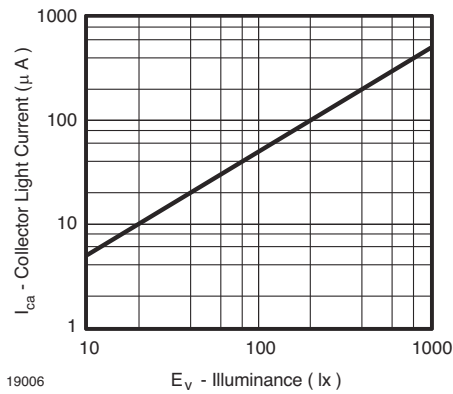

Figure 1. Collector Light Current vs. Illuminance

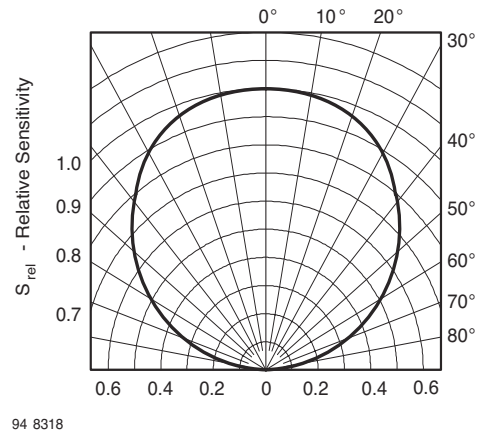

Figure 3. Relative Radiant Sensitivity vs. Angular Displacement

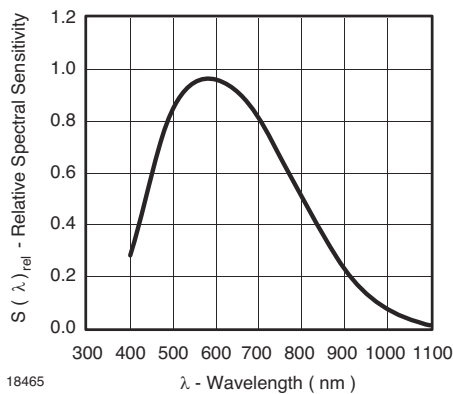

Figure 2. Relative Spectral Responsivity vs. Wavelength

Reflow Solder Profiles

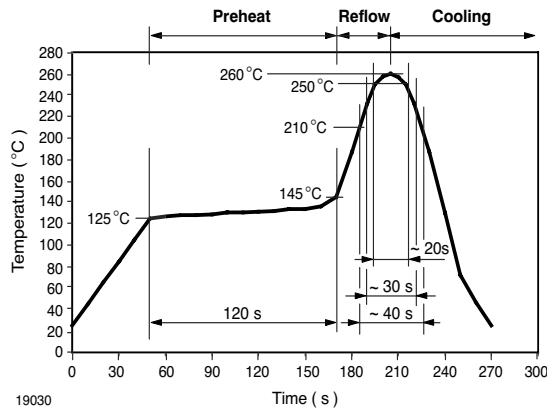

Figure 4. Lead-Free (Sn) Reflow Solder Profile

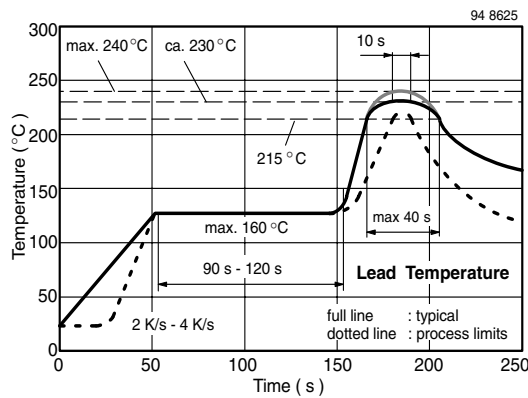

Figure 5. Lead Tin (SnPb) Reflow Solder Profile

Drying

In case of moisture absorption devices should be baked before soldering. Conditions see J-STD-020 or Label. Devices taped on reel dry using recommended conditions 192 h @ 40 °C (+ 5 °C), RH < 5 %

Drypack

Devices are packed in moisture barrier bags (MBB) to prevent the products from moisture absorption during transportation and storage. Each bag contains a desiccant.

Floor Life

Floor life (time between soldering and removing from MBB) must not exceed the time indicated in J-STD-020. TEMT6000 is released for: Moisture Sensitivity Level 4, according to JEDEC, J-STD-020
Floor Life: 72 h
Conditions: $T_{amb} < 30\text{ °C}$, RH < 60 %

Package Dimensions in mm

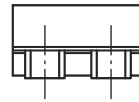
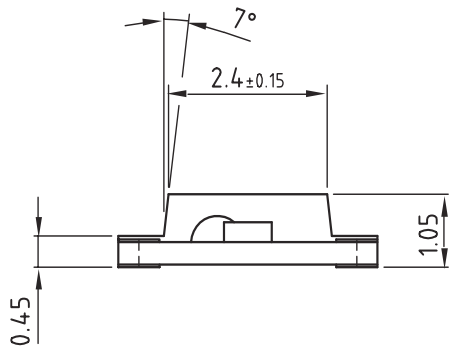

technical drawings
according to DIN
specifications

All dimensions in mm

Not indicated tolerances ± 0.1

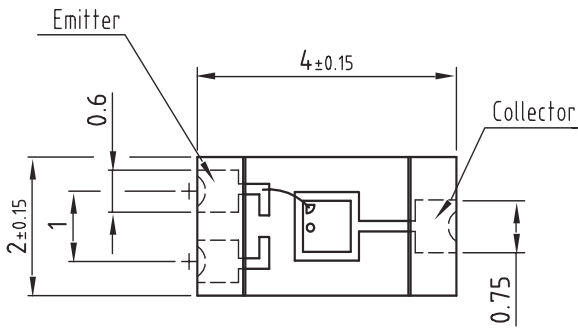

Recommended solder pad
Footprint

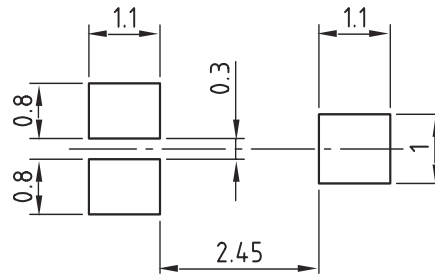

18464

Drawing-No.: 6.541-5053.01-4
Issue: 2; 21.06.04

Ozone Depleting Substances Policy Statement

It is the policy of **Vishay Semiconductor GmbH** to

1. Meet all present and future national and international statutory requirements.
2. Regularly and continuously improve the performance of our products, processes, distribution and operating systems with respect to their impact on the health and safety of our employees and the public, as well as their impact on the environment.

It is particular concern to control or eliminate releases of those substances into the atmosphere which are known as ozone depleting substances (ODSs).

The Montreal Protocol (1987) and its London Amendments (1990) intend to severely restrict the use of ODSs and forbid their use within the next ten years. Various national and international initiatives are pressing for an earlier ban on these substances.

Vishay Semiconductor GmbH has been able to use its policy of continuous improvements to eliminate the use of ODSs listed in the following documents.

1. Annex A, B and list of transitional substances of the Montreal Protocol and the London Amendments respectively
2. Class I and II ozone depleting substances in the Clean Air Act Amendments of 1990 by the Environmental Protection Agency (EPA) in the USA
3. Council Decision 88/540/EEC and 91/690/EEC Annex A, B and C (transitional substances) respectively.

Vishay Semiconductor GmbH can certify that our semiconductors are not manufactured with ozone depleting substances and do not contain such substances.

**We reserve the right to make changes to improve technical design
and may do so without further notice.**

Parameters can vary in different applications. All operating parameters must be validated for each customer application by the customer. Should the buyer use Vishay Semiconductors products for any unintended or unauthorized application, the buyer shall indemnify Vishay Semiconductors against all claims, costs, damages, and expenses, arising out of, directly or indirectly, any claim of personal damage, injury or death associated with such unintended or unauthorized use.

Vishay Semiconductor GmbH, P.O.B. 3535, D-74025 Heilbronn, Germany
Telephone: 49 (0)7131 67 2831, Fax number: 49 (0)7131 67 2423