



HESTORE.HU

elektronikai alkatrész áruház

EN: This Datasheet is presented by the manufacturer.

Please visit our website for pricing and availability at www.hestore.hu.

Microcomputer Temperature Controller User Manual

Model:RC-112E

Product Introduction

The product adopts the latest electronic technique with LED display, which learn from the advantages and experience of stand-alone edition temperature controllers domestically and overseas. It is the most economical product with simple operation, stable performance, small size and intelligent control, cool and heat shift functions, which applies to various refrigeration and heating places and equipments.

Product Picture



Parameters

Temperature measure range: -40~99℃

Resolution: 1

Accuracy: ±1℃

Power supply: 220VAC/110VAC/12V±10%,50/60HZ

Input: one NTC sensor

Output: one relay 10A/220VAC

Ambient requirements: temperature: -10~60℃; humidity: 20~85% (No condensate)

Cut-out size: 71mm×29mm

Consumption: ≤3W

Indicator Description

WORK indicator: means the output load is in working status; Normally on means work; flash means delay; Off means not work.

SET indicator: means set status, Normally on means work; Off means not work.

Operation Instruction

Buttons: SET , UP \nearrow , DOWN \searrow , POWER \downarrow

1. Temperature setting:

In normal working status, press SET, display the current temperature value, use UP or DOWN button to adjust the ideal temperature you want. Tips: press on UP or DOWN can enter into rapid adjustment. After adjustment, press SET to return to normal working status, or without any operation for 15 seconds, the controller will return to normal working status and save the adjustments.

2. Maintain Parameters Setting:

In normal working status, press on SET for 3 seconds, set indicator is on, and enter into maintain menu. When display HC, use UP or DOWN button to adjust the mode you want. Tips: press on UP or DOWN can enter into rapid adjustment. After adjustment, press SET to the next parameter, use the same method to set the rest parameters. When finishing, press on SET for 3 seconds or without any operation for 15 seconds, the controller will return to normal working status and save the adjustments.

3. Switch on and off:

In the off status, press POWER button to switch on; in the on status, press POWER button 5 seconds to switch off the controller.

Function Menu

Code	Function	Setting Range	Default	Unit
HC	mode	[: cool H : heat	[/
d	differential	1~15	3	C
LS	low temp.	-40~setting temp.	-40	C
HS	high temp.	setting temp.~99	99	C
CA	calibration	-5~5	0	C
PE	delay time	0~15	3	Min.

Function Description

1. Temperature Calibration

When there is difference between the measuring temp. and the standard temp., this function can keep the measuring temp. same as the standard temp.

Temp. after calibration =Temp. before calibration.+adjusted value

2. Cool and Heat Function:

In cool mode:

A. Cooling systems works in below situation:

The measuring temperature \geq the set temperature + the temperature differential

B. Cooling systems stop working in below situation:

The measuring temperature \leq the set temperature

In heat mode:

A. Heating systems works in below situation:

The measuring temperature \leq the set temperature - the temperature difference;

B. Heating systems stop working in below situation:

The measuring temperature \geq the set temperature

3. Delay Time:

When power on for the first time, if The measuring temperature \geq the set temperature + the temperature differential or The measuring temperature \leq the set temperature - the temperature difference, the output will not be activated immediately, and will be activated after the delay time.

If the time period between the previous stop and this starts is longer than the delay time, the output will be activated immediately; if it is shorter than the delay time, the output will be activated after the delay time. The delay time is calculated from the previous output stop.

4. High and low temperature limit:

HS and LS can set the high and low limit of the setting temperature:

For example: HS is +15, LS is -10, the temperature only can be set between -10~+15°C; so if you want to set a value beyond this range, please reset the HS and LS firstly.

Error Code

1. Sensor error alarm

When the controller is in power on status, if sensor open circuit, LED flash and display “__”,if sensor short circuit, display “HH”. When in sensor error status, the output load will run as the cycle: stop 15 minutes, then work 15 minutes.

2. Over temperature alarm

When the sensor temperature $>99^{\circ}\text{C}$, display HH; When the sensor temperature $<-40^{\circ}\text{C}$, display LL.

Accessory

One sensor wire/two plastic supports/one user manual

Wiring Diagram

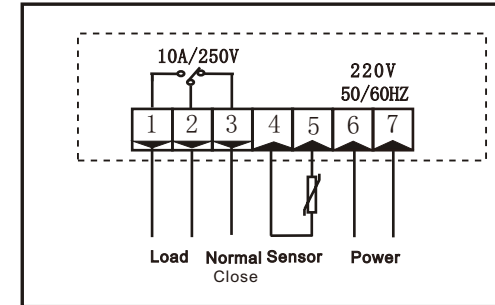

Installation notes:

1. Before use, please carefully read the user manual, must distinguish the functions of the different contact points. The connected load power should not exceed the capacity of contact point (if exceeding, please connect AC contactor). Each connecting wire should be connected to the terminals firmly.
2. Please install the device firmly in a stable place, avoid crash. The device cannot be placed with dripping or water, and keep away from the electromagnetic interference of the electrical apparatus.
3. In order to prevent the interference of high frequency, the sensors and low voltage lines cannot parallel and be bundled up with high voltage line. The diameter of the high voltage wire must be between 0.75 mm and 1.5mm.
4. If the device is disturbed, please cut off the power, and restart. This software belongs to class A, which is not applicable to safety protection control.
5. Do not privately disassemble the device. If faults occur or have questions of the usage, please contact our company.

