



HESTORE.HU

elektronikai alkatrész áruház

EN: This Datasheet is presented by the manufacturer.

Please visit our website for pricing and availability at www.hestore.hu.

On-Board Type (DC) EMI Suppression Filters (EMIFIL®)



Disc Type EMIFIL® DSN6/DSS6 Series

■ Features

DS_6 is compact, high performance lead type EMI suppression filter which can be mounted 2.54mm pitch. Its three-terminal structure enables nice high frequency performance.

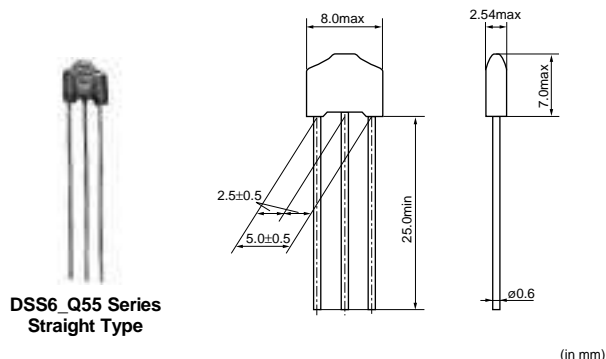
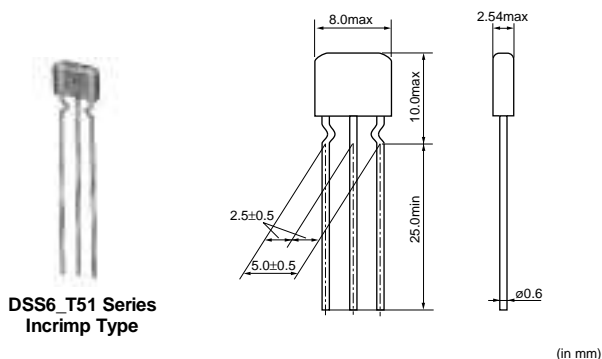
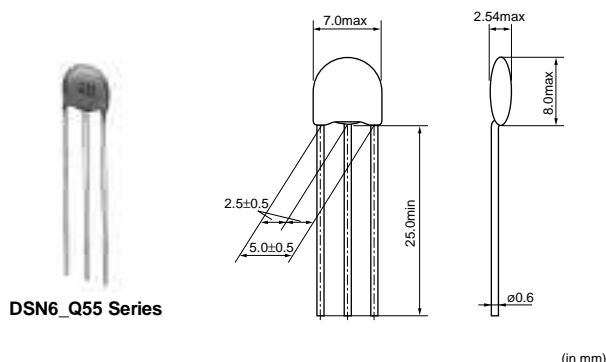

DSN6 Series

Part Number	Capacitance (pF)	Rated Voltage (Vdc)	Rated Current (A)	Operating Temperature Range (°C)
DSN6NC51H220Q55B	22 +20%, -20%	50	6	-25 to 85
DSN6NC51H330Q55B	33 +20%, -20%	50	6	-25 to 85
DSN6NC51H470Q55B	47 +20%, -20%	50	6	-25 to 85
DSN6NC51H101Q55B	100 +20%, -20%	50	6	-25 to 85
DSN6NC51H271Q55B	270 +20%, -20%	50	6	-25 to 85
DSN6NC51H102Q55B	1000 +20%, -20%	50	6	-25 to 85
DSN6NC51H222Q55B	2200 +20%, -20%	50	6	-25 to 85
DSN6NZ81H103Q55B	10000 +80%, -20%	50	6	-25 to 85

■ Insertion Loss Characteristics (Typical)

DSN6 Series

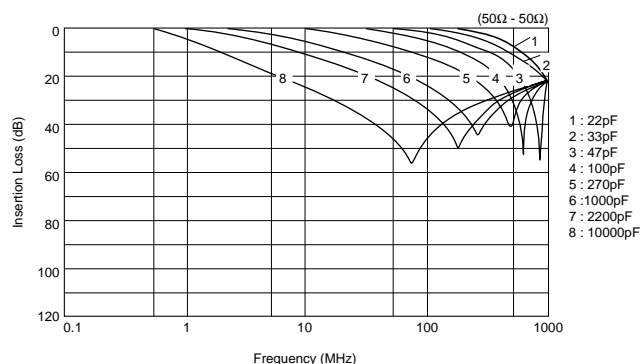

Built-in Ferrite Beads DSS6 Series Incrimp Type

Part Number	Capacitance (pF)	Rated Voltage (Vdc)	Rated Current (A)	Operating Temperature Range (°C)
DSS6NC52A220T51B	22 +20%, -20%	100	6	-25 to 85
DSS6NC52A330T51B	33 +20%, -20%	100	6	-25 to 85
DSS6NC52A470T51B	47 +20%, -20%	100	6	-25 to 85
DSS6NC52A101T51B	100 +20%, -20%	100	6	-25 to 85
DSS6NC52A151T51B	150 +20%, -20%	100	6	-25 to 85
DSS6NC52A221T51B	220 +20%, -20%	100	6	-25 to 85
DSS6NC52A271T51B	270 +20%, -20%	100	6	-25 to 85
DSS6NC52A471T51B	470 +20%, -20%	100	6	-25 to 85
DSS6NC52A102T51B	1000 +20%, -20%	100	6	-25 to 85
DSS6NE52A222T51B	2200 +80%, -20%	100	6	-25 to 85
DSS6NZ82A103T51B	10000 +30%, -30%	100	6	-25 to 85
DSS6NF31C223T51B	22000 +80%, -20%	16	6	-25 to 85

■ Insertion Loss Characteristics (Typical)

DSS6_T51 Series

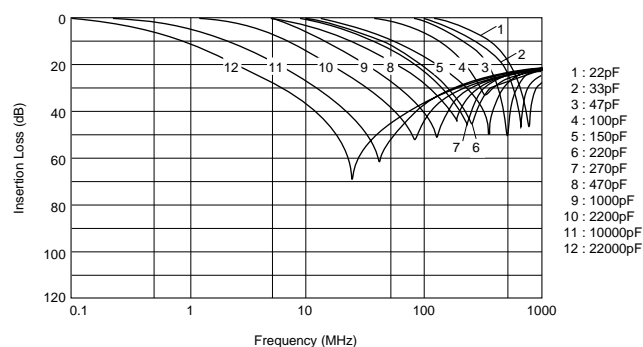

20

Built-in Ferrite Beads DSS6 Series Straight Type

Part Number	Capacitance (pF)	Rated Voltage (Vdc)	Rated Current (A)	Operating Temperature Range (°C)
DSS6NC52A220Q55B	22 +20%, -20%	100	6	-25 to 85
DSS6NC52A330Q55B	33 +20%, -20%	100	6	-25 to 85
DSS6NC52A470Q55B	47 +20%, -20%	100	6	-25 to 85
DSS6NC52A101Q55B	100 +20%, -20%	100	6	-25 to 85
DSS6NC52A151Q55B	150 +20%, -20%	100	6	-25 to 85
DSS6NC52A221Q55B	220 +20%, -20%	100	6	-25 to 85
DSS6NC52A271Q55B	270 +20%, -20%	100	6	-25 to 85
DSS6NC52A471Q55B	470 +20%, -20%	100	6	-25 to 85
DSS6NC52A102Q55B	1000 +20%, -20%	100	6	-25 to 85
DSS6NE52A222Q55B	2200 +80%, -20%	100	6	-25 to 85
DSS6NZ82A103Q55B	10000 +30%, -30%	100	6	-25 to 85
DSS6NF31C223Q55B	22000 +80%, -20%	16	6	-25 to 85

■ Insertion Loss Characteristics (Typical)

DSS6_Q55 Series

