



HESTORE.HU

elektronikai alkatrész áruház

EN: This Datasheet is presented by the manufacturer.

Please visit our website for pricing and availability at www.hestore.hu.

ASI®-F solar module

Framed module for 12-V applications

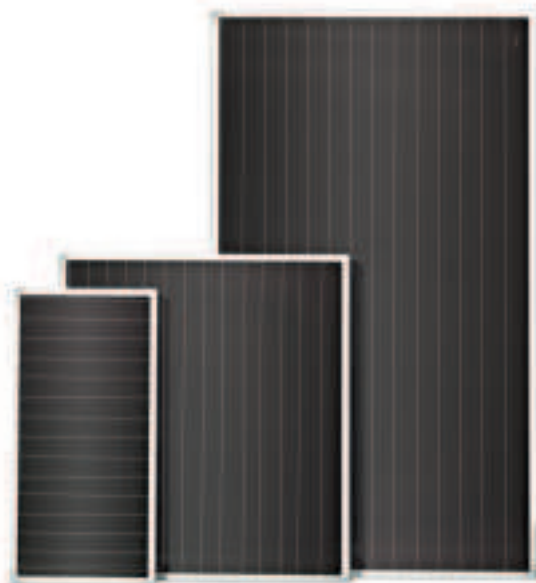

ASI®-F 2-10/12

- More energy
- Excellent value for money
- Robust encapsulation
- Easy mounting
- 10 years power guarantee
- IEC 61646 certified

More energy: Independent surveys have shown that - under realistic conditions such as unfavourable lighting situation or high temperature - our ASI®-Technology produces approximately 20% more energy per rated Wp than crystalline modules.

Excellent value for money: The optimal use of raw materials and automated manufacturing processes ensures favourable prices, high performance and environmental viability for all ASI®-F modules.

Robust encapsulation: The proven ASI®-F encapsulation ensures high resistance against UV, temperature and weather, even in the most extreme conditions. The torsion-proof aluminium dished frame with integrated corner links offers optimal protection against mechanical wear or damage.

Simple mounting: All ASI®-F modules have a junction box for variable circuiting. The oblong holes in the aluminium frame allow easy and universal mounting.

Top quality and safety: The proven ASI®-F modules "Made in Germany" stand for high, stable performance and longevity:

- 10 years power guarantee
- IEC 61646 certified
- ISO 9001 and ISO 14001 certified



Robust encapsulation



Easy mounting

ASI®-F solar modules are available as power class 2 – 10, 16 and 32 Wp. The patented ASI®-Technology with its special stacked-cell design on the basis of silicon thin film guarantees years of unfaltering high performance. Each type of module is ready for mounting, and all parts, from the frame to the junction box, are designed for easy and inexpensive system integration. Typical applications of a 12 V system are lighting, traffic systems, telecommunication, safety technology, mini solar home systems, consumer and leisure products. ASI®-F modules combine state-of-the-art solar module technology with proven encapsulation, offering decisive advantages:

Solar modules



	ASI-F 2/12	ASI-F 4/12	ASI-F 5/12	ASI-F 8/12	ASI-F 10/12
Initial Nominal Power [Wp]	2.6	4.7	6.3	9.5	12.5
Nominal Power P_{nom} [Wp]*	2.1	3.9	5.2	7.8	10.3
Voltage at nominal power U_{mpp} [V]*	16.8	16.8	16.8	16.8	16.8
Current at nominal power I_{mpp} [mA]*	125	232	309	464	613
Open-circuit current I_{sc} [mA]*	165	293	398	602	808
Open-circuit voltage U_{oc} [V]*	22.8	22.8	22.8	22.8	22.8

The quoted figures are subject to a production tolerance of $\pm 10\%$.

* These data represent stabilized electrical module performance at standard test conditions (STC – 1000 W/m², spectrum AM 1.5, 25 °C cell temperature). The nominal power may be initially approx. 18 % higher than the quoted stabilised power data.



Width [mm]	X	144	249	330	293	330
Length [mm]	Y	293	293	293	493	581
Hole distance horizontal [mm]	Z ₁	114	219	300	263	300
Hole distance vertical [mm]	Z ₂	180	180	180	380	468
Weight [kg]		0.6	0.9	1.2	1.6	2.1

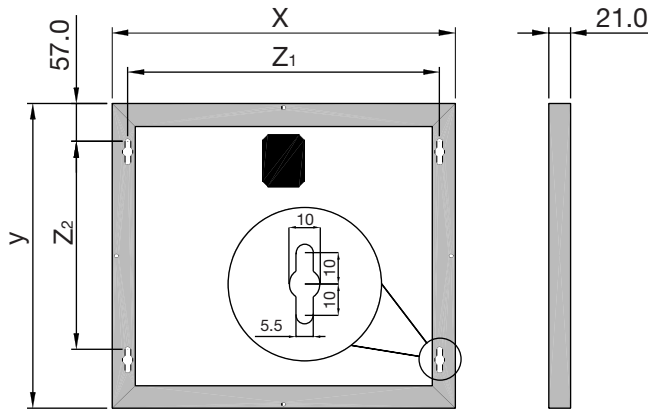

Permissible module temperature [°C]	-40 °C to +85 °C
Typical operation temperature [°C]	approx. 20 °C to 25 °C above ambient temperature



Temperature coefficient [%/K]	P_n : -0.2 / U_{oc} : -0.33 / I_{sc} : 0.08
	The temperature dependence of the nominal power rating is especially low



Qualification	IEC 61646 certified
	CE conformity

Specifications are subjected to change without notice.

RWE SCHOTT Solar GmbH
 Hermann-Oberth-Str. 11
 85640 Putzbrunn, Germany
 P +49 (0) 89 / 4 62 64 - 100
 F +49 (0) 89 / 4 62 64 - 111
 E phototronics-sales@rweschottsolar.com
 I www.rweschottsolar.com

RWE
SCHOTT Solar